



FA Equipment for Beginners (Power Distribution Control Products)

The objective of this course is to provide an overview of electrical power distribution and control equipment in a short amount of time for individuals who are new to the field.

Introduction Educational objectives of this course



This course is provided in order for you to learn the fundamental knowledge necessary to use Mitsubishi electrical power distribution and control equipment such as those shown below.

The content of this course has been created based on the standards of electrical power distribution systems used in Japan. The standards of electrical voltages or electrical currents vary depending on the country, so you should consider this document as only an educational reference.

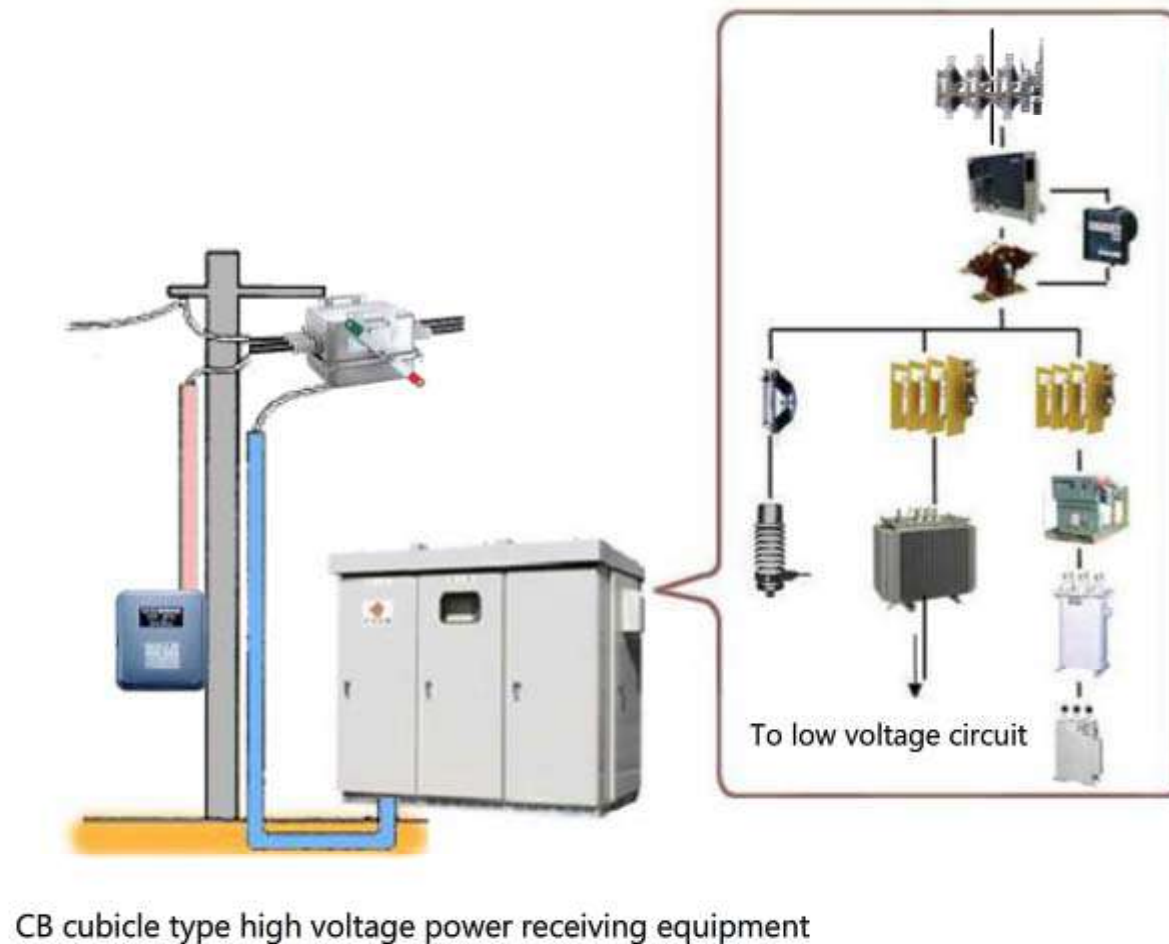
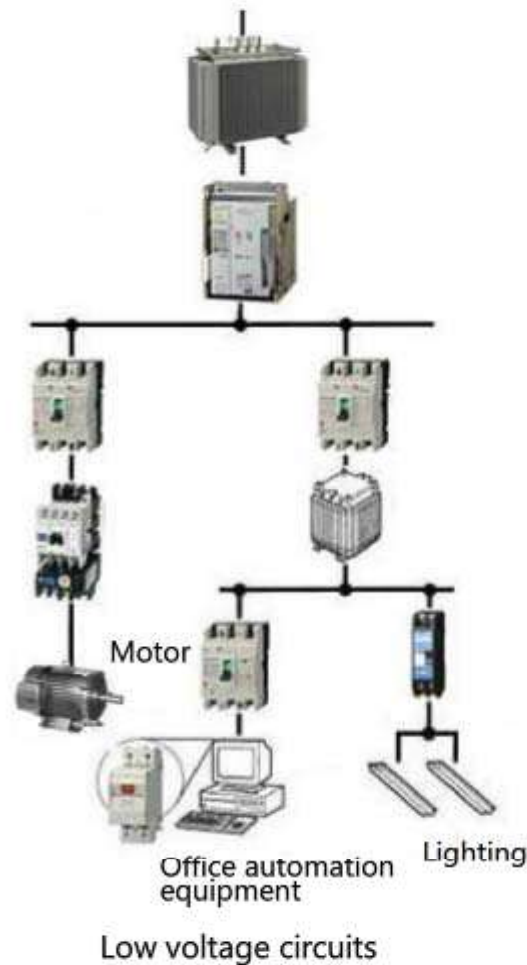

Introduction Course chapter structure



The chapters of this course are laid out as follows.
We recommend that you study the chapters in order, starting with Chapter 1.

Chapter 1 - Electricity fundamentals

This chapter teaches a basic understanding of electricity.

Chapter 2 - From power station to consumer

This chapter discusses how electrical power is sent to and made accessible to consumers.

Chapter 3 - Power distribution and control equipment

In this chapter, you will gain a broad understanding of distribution and control equipment.

Introduction **Operating Instructions**

Go to the next page		Go to the next page.
Back to the previous page		Back to the previous page.
Move to the desired page		"Table of Contents" will be displayed, enabling you to navigate to the desired page.
Exit the learning		Exit the learning. Window such as "Contents" screen and the learning will be closed.

Introduction **Important Information**

Safety Instructions

When you study using the actual product, we ask that you carefully read the "Safety Instructions" described in the product manual, and use the product in a proper manner while paying careful attention to the safety issues.

Chapter 1 Electricity Fundamentals



In this chapter, you will learn a basic understanding about electricity necessary to use the power distribution and control equipment.

Chapter 1 Study Content

- 1.1 What is electricity?
- 1.2 Ohm's law (The relationship of voltage, current, and resistance)
- 1.3 Direct current and alternating current
- 1.4 Fundamental elements of alternating current circuits
- 1.5 About electrical power and power factor
- 1.6 Electrical power and electrical energy in single phase circuits
- 1.7 Electrical power and electrical energy in three-phase circuits

1.1

What is electricity?



When we talk about electricity, what do we mean exactly? We all know about a voltage of 100 volts and current of 10 amperes, but it is difficult to explain in words what these mean.

Electricity is easier to understand if we consider about it using water as an example.

• Voltage

If we consider water, the pressure of water (water pressure) is equivalent to the pressure of electricity (electrical voltage).

The force for pushing water becomes stronger as the water pressure increases, and in the same way, the force for feeding a current becomes stronger as the pressure of electricity (electrical voltage) increases.

This pressure of electricity (voltage) is measured using the unit of the volt [V], and a voltage is expressed as 100 V, 200 V, and so on.

• Electrical Current

The flow of water is called a water current, and the flow of electricity is called an electrical current.

Just as with water, an electrical current always flows from a high potential to a low potential.

The unit for measuring an electrical current is **ampere [A]**.

• Resistance

If a water conduit is narrow or becomes coated with algae, water is obstructed (resisted) from the smooth flow. Similar to such symptom, an obstacle that blocks the flow of electricity is called **electrical resistance**.

The unit for measuring an electrical resistance is **ohm [Ω]**.

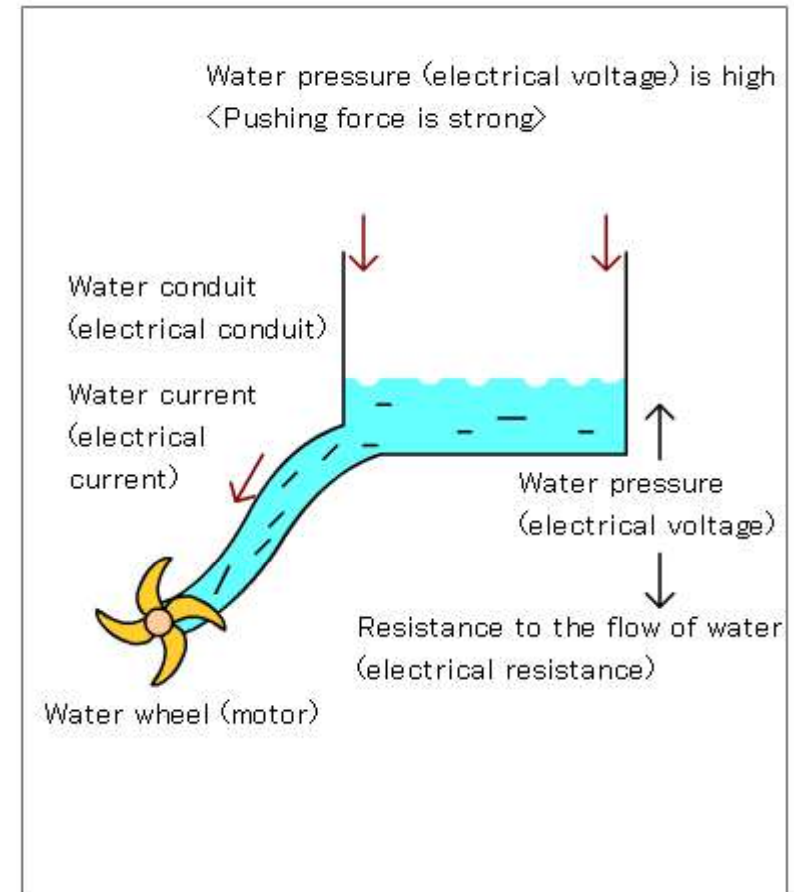

1.2

Ohm's law (The relationship of voltage, current, and resistance)



In an electrical circuit, applying voltage to the resistance (load) feeds the electric current.

The amount of such current is proportional to the voltage and inversely proportional to the resistance.

This statement is called "Ohm's law".

It is represented by the following formula:

$$I = \frac{E}{R} \text{ [A]}$$

In this equation,

I: Electrical current [A]

E: Electrical voltage [V]

R: Electrical resistance [Ω]

Transforming the above equation, we get:

$$E = I \times R \text{ [V]}$$

As the above equations show, a current increases as a voltage increases, while a current increases as a resistance decreases.

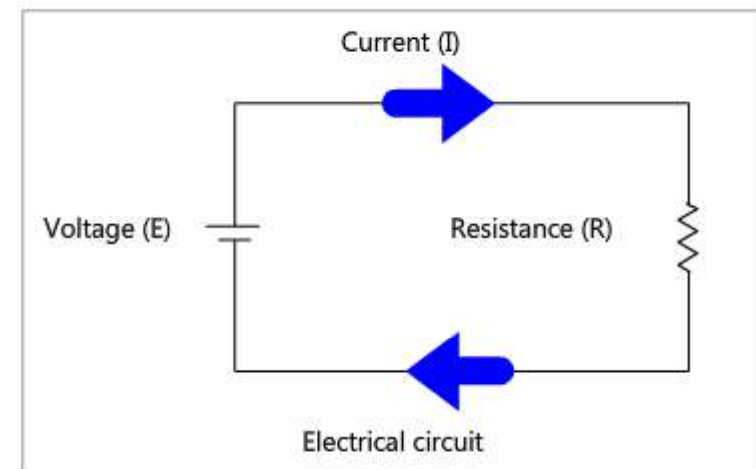
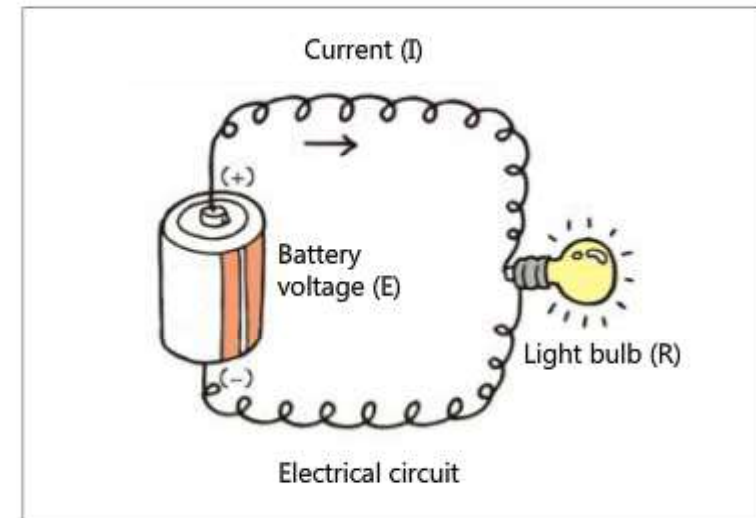

1.3

Direct current and alternating current



- **Direct current (Figure 1 to 3)**

The best known example of a direct current is a dry cell battery. It has positive (+) and negative (-) terminals, and electricity from the power supply always flows in a single direction only.

When a battery is connected to a light bulb, a current always flows from the + terminal and returns to the - terminal.

This was determined when electricity was not well understood. In actuality, electrons which hold negative (-) electrical charge are moving in the opposite direction.

- **Alternating current**

Alternating current changes its direction and size as time progresses.

Figure 4 shows an alternating current that is created by an electrical generator which is called sine wave alternating current.

The alternating current that we generally indicate refers to this sine wave alternating current.

Current flows in one fixed direction.

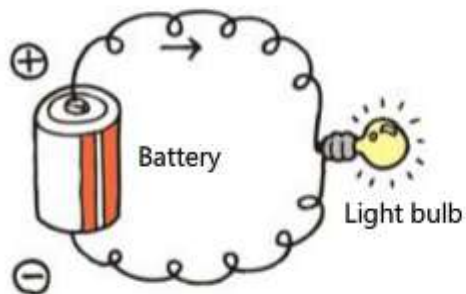

Fig.1. Flow of electrical current

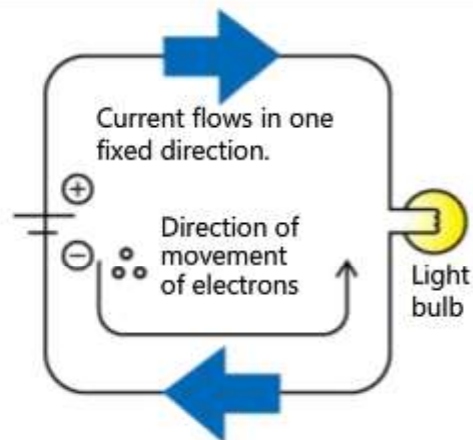

Fig.2. Direction of movement of electrons

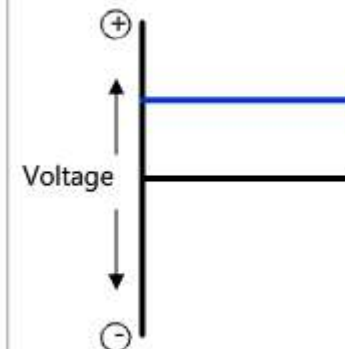

Fig.3. Direct current

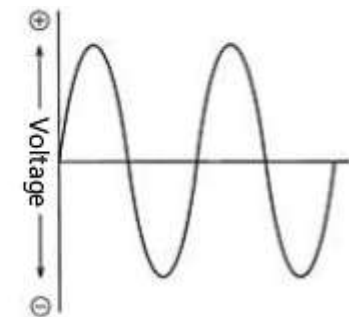

Fig.4. Sine wave alternating current

1.3

Direct current and alternating current



- **Frequency**

A frequency means the number of periods repeated by an alternating current in one second.

The frequency of 50 Hz means that the current alternately changes its direction of flow 50 times per second as shown in the figure to the right.

- **Effective Value**

Since the voltage E of the alternating current changes with time, there is the problem that the value exactly indicates the voltage of 100 volts is not obvious.

Normally, such value is expressed by the effective value of the energy that would be the same in the case of a direct current.

The effective value of the sine wave alternating current is:

$$E = \frac{E_m}{\sqrt{2}}$$

where E is the effective value, and E_m is the maximum value.

Generally speaking, a voltage of 100 volts indicates the effective value, and the maximum value E_m of the alternating current is

$$E_m = 100 \text{ V} \times \sqrt{2} = 100 \text{ V} \times 1.41 = 141 \text{ V}$$

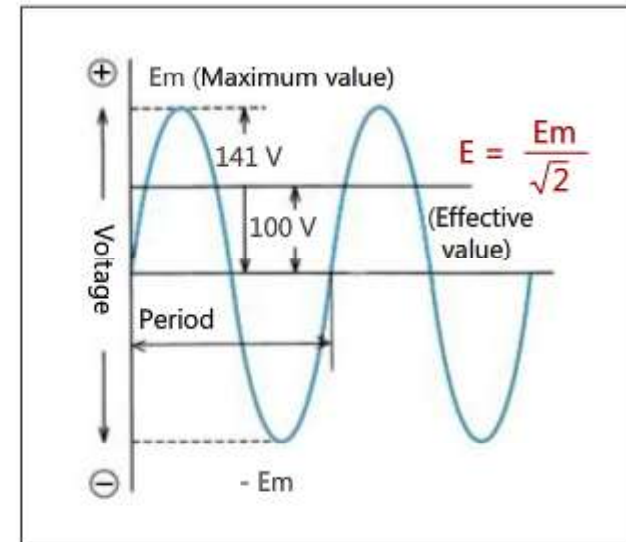

Side Note

The effective value of an alternating current is calculated as "the square root of the mean of the square of the instantaneous value in 1 period."

We call the effective value "rms" which comes from taking the first initials of the terms Root, Mean, and Square.

The above effective value E can be calculated with the following formula, using the instantaneous value $e = E_m \sin \omega t$.

$$E = \sqrt{\frac{1}{T} \int_0^T e^2 \cdot dt}$$

1.4

Fundamental elements of alternating current circuits

In direct current circuits, a coil does not hamper the flow of current. However, in alternating current circuits, in addition to pure resistance, coils and capacitors act as resistance. All of these kinds of resistance are together called impedance.

- **Resistance**

When the alternative current voltage E is applied to the resistance of R [Ω], the current I that flows through the resistance circuit is:

$$I = \frac{E}{R}$$

You can think of it as being the same as in the case of a direct current. In this situation, the voltage and the current are in phase with each other.

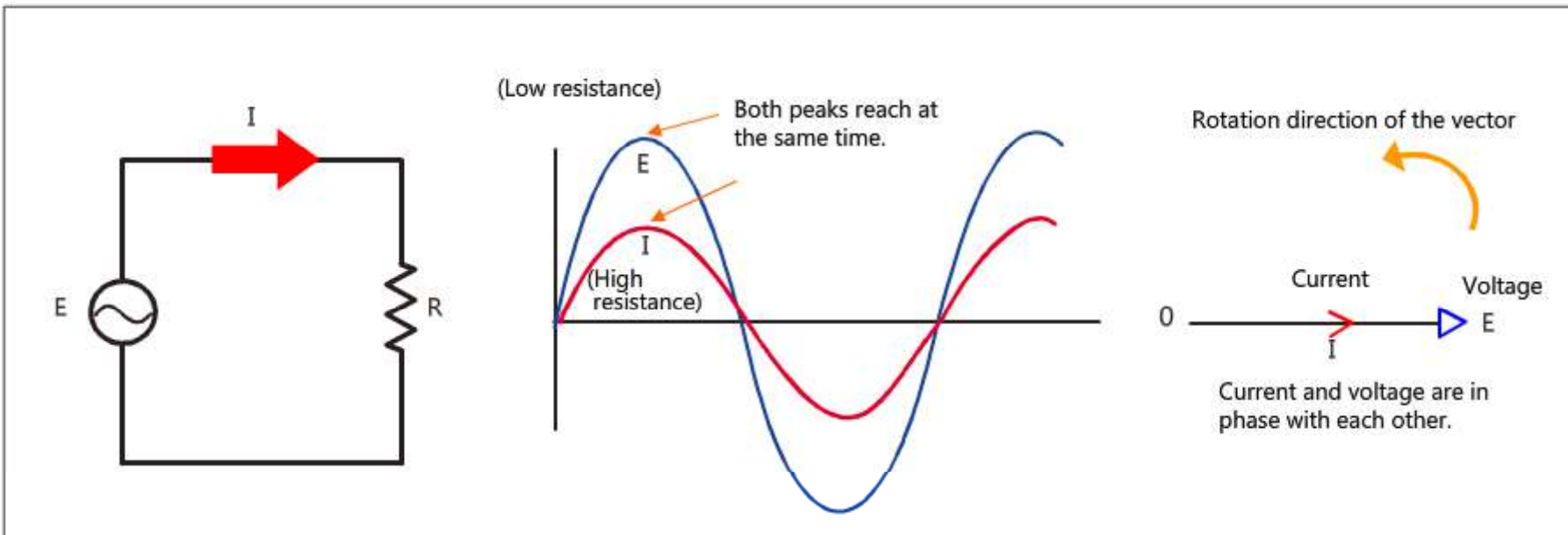

1.4

Fundamental elements of alternating current circuits



- **Coils (Inductive reactance)**

A coil acts as a kind of resistance to an alternating current. The amount of such resistance is expressed as an inductive reactance.

$$\text{Inductive reactance } X_L = 2\pi fL = \omega L [\Omega]$$

where π : Angular speed, f : Frequency, L : Self-inductance.

The current I that flows in the circuit is

$$I = \frac{E}{X_L}$$

Thus, Ohm's law is satisfied.

Current is 90° behind the voltage.

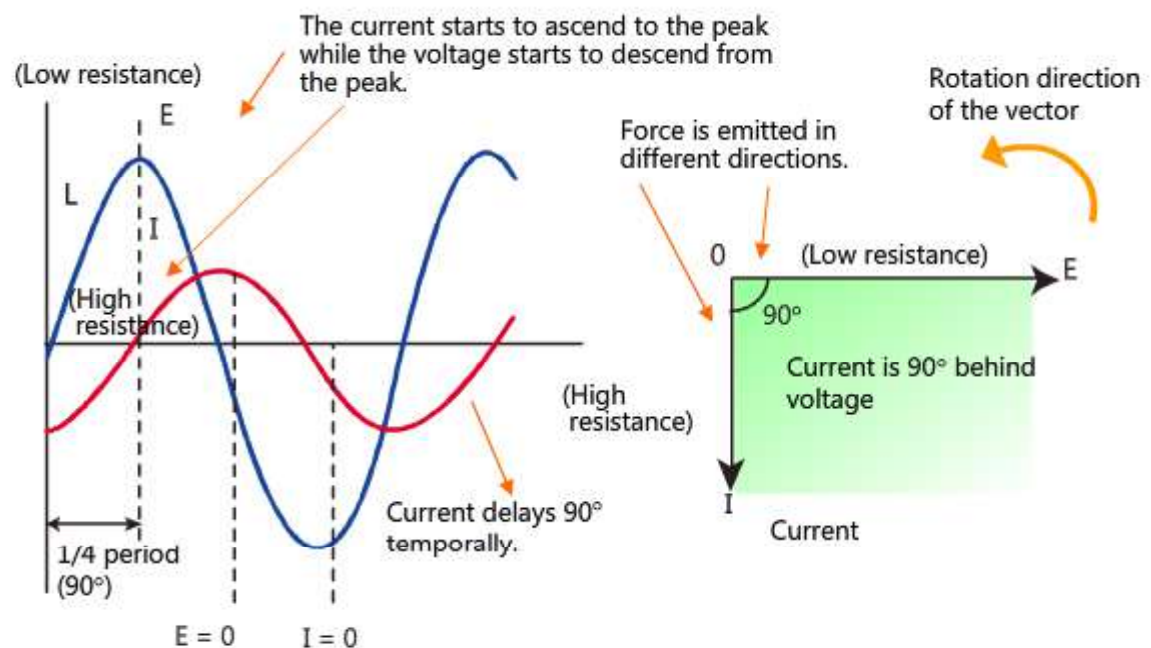
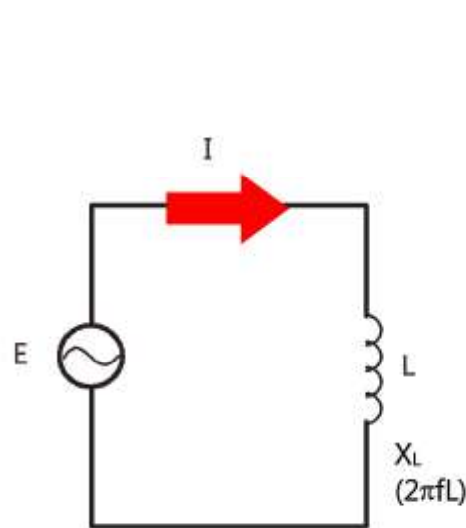

1.4

Fundamental elements of alternating current circuits

- **Capacitors (Capacitive reactance)**

When an alternating current voltage is applied to the capacitor C, a charging current and a discharging current flow as shown in the diagram.

Also in this case, such current acts as a kind of resistance to an alternating current.

This is called a capacitive reactance.

$$\text{Capacitive reactance } X_c = \frac{1}{2\pi fC} = \frac{1}{\omega C} \text{ } [\Omega]$$

where ω : Angular speed, f: Frequency, C: Capacitance

The current I that flows in the circuit is

$$I = \frac{E}{X_c}$$

Thus, Ohm's law is satisfied.

Current advances 90° ahead of the voltage.

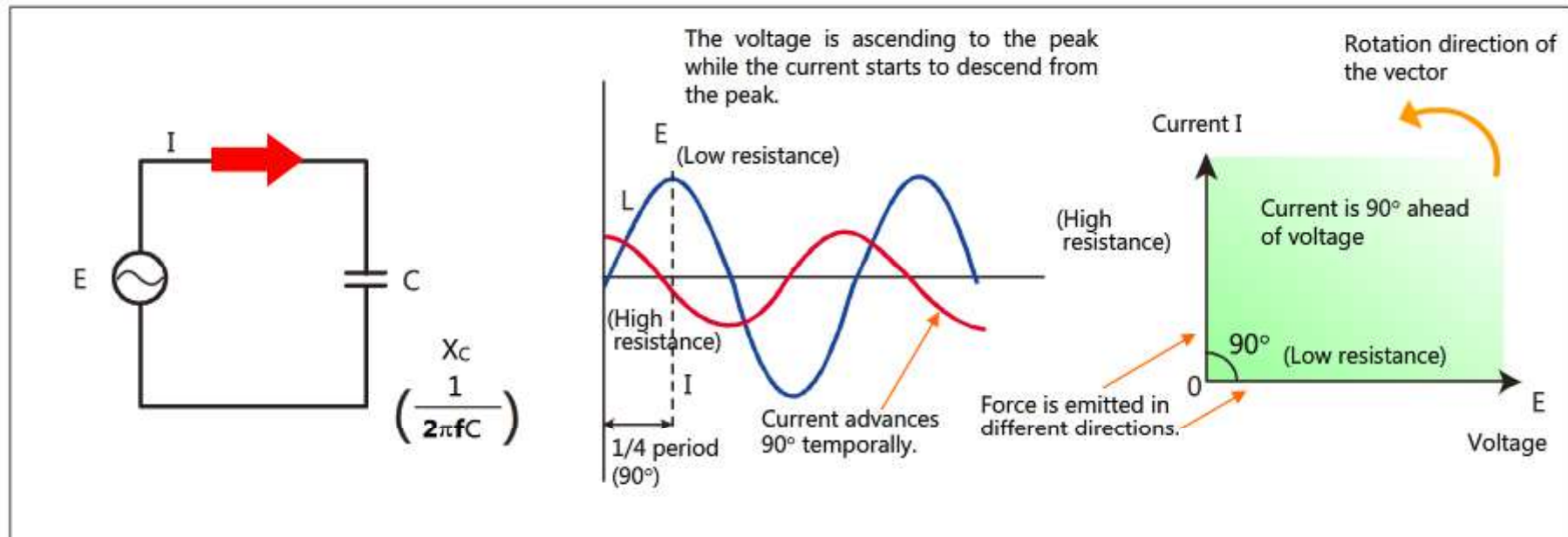

1.4

Fundamental elements of alternating current circuits



• **Impedance (A combination of resistance and reactance)**

In alternating current circuits, a combination of pure resistance and the reactance that acts as a resistance such as coils and capacitors is handled as an impedance.

The unit for measuring is ohm (Ω), as in the case of a resistance.

Since the directions of vectors differ when combining a resistance and a reactance, instead of simply using an arithmetic sum, we need to use their vector sum, as in the following formula.

$$Z = \sqrt{R^2 + X^2}$$

$$X = (X_L - X_C)$$

$$I = \frac{E}{Z}$$

where Z: Impedance (Ω), R: Resistance (Ω), X: Reactance (Ω).

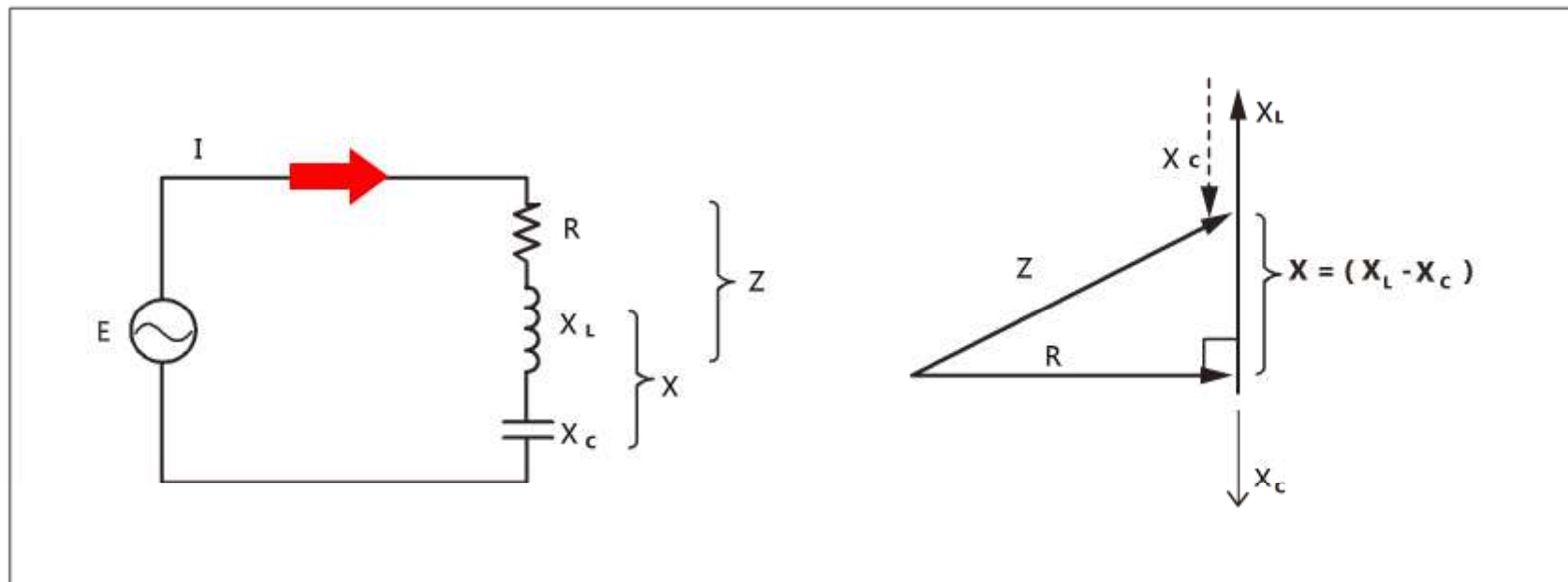

1.5

About electrical power and power factor



- **Electrical Power**

When water is applied to a waterwheel, the power to turn the waterwheel is (water pressure) x (water current).

The power of electricity that is equivalent to this force of water is called an electrical power. The amount of the electrical power is (electrical voltage) x (electrical current), and the unit for measuring is watt [W].

In other words,

$$\text{Electrical power} = \text{Voltage} \times \text{Current}$$

- **Power Factor**

In alternating current circuits, due to coils and capacitors, the forces from voltage and current operate in different directions. When we are talking about electricity, this angle is called a phase difference.

When the cosine of such phase difference (the angle), in other words, phase difference, is ϕ , $\cos \phi$ is regarded as a power factor. If this power factor is poor (when the difference of the directions between the voltage and the current becomes greater), the less force is generated even from the same voltage and current.

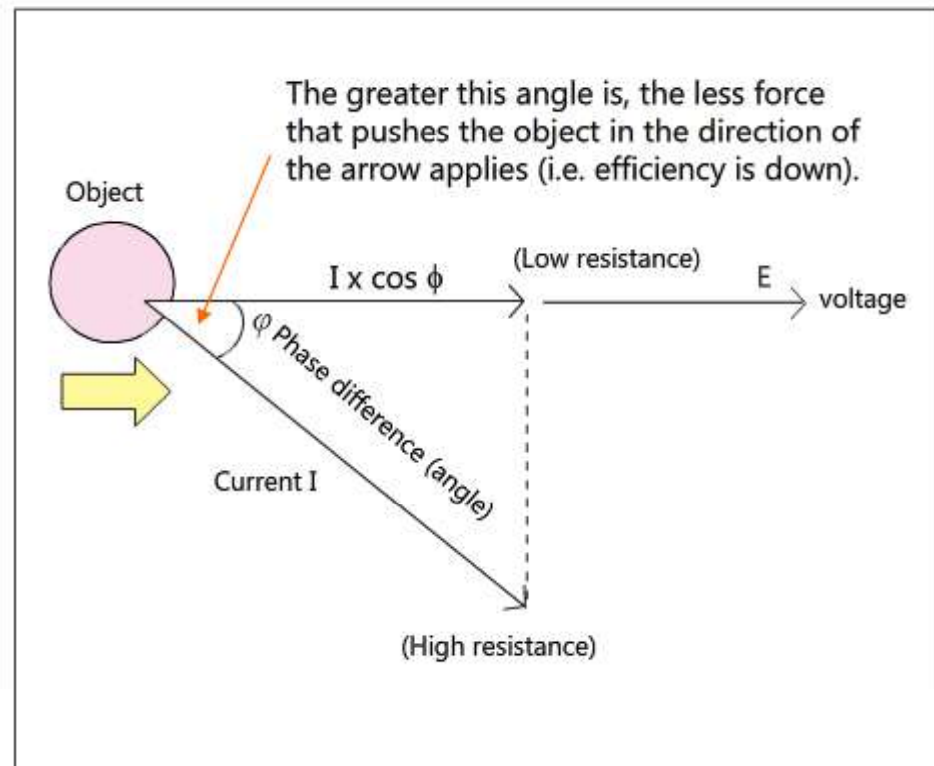
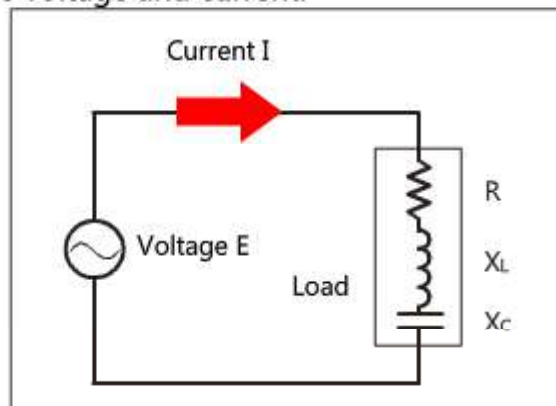

1.6

Electrical power and electrical energy in single phase circuits



The 100 V used in homes normally is a single phase. In principle, there are two electrical wires that come from the power supply of a single phase. With regard to an electrical power in a single phase alternating current circuit, because the time when the strongest force is generated is different between the voltage and the current, instead of simply multiplying the voltage and the current, we use the following formula.

Single phase alternating current electrical power = Voltage x Current x Power factor

$$P1 = E \times I \times \cos \phi \text{ [W]}$$

$$P0 = E \times I \text{ [VA]}$$

where P1: Effective power [W], P0: Apparent power [VA], $\cos \phi$: Power factor.

By multiplying the time, we get the electrical energy.

Single phase alternating current electrical energy = Power x Time

$$Ph = P1 \times t = E \times I \times \cos \phi \times t \text{ [Wh]}$$

where Ph: Electrical energy [Wh], T: time [h].

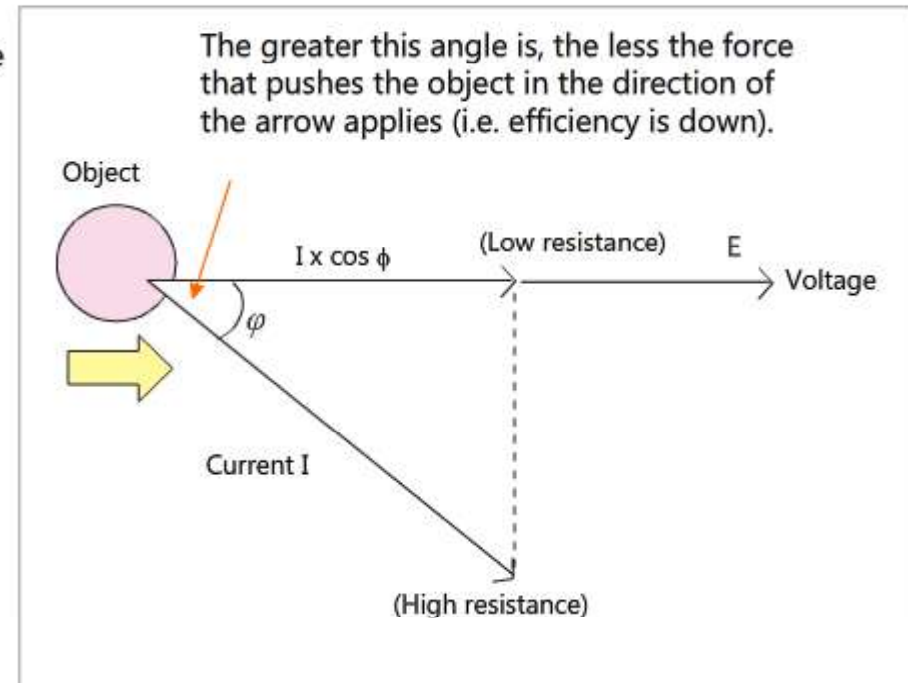

1.7

Electrical power and electrical energy in three-phase alternating current circuits



The motors used to provide driving force are generally three-phase. Three-phase in principle uses three electrical wires, although there are cases where four wires are used, which are called three-phase four-wire systems.

As shown in Figure 1, three-phase alternating current has three waves of **u**, **v**, and **w** in one power supply. These waves are offset by 1/3 of a cycle.

When this is used as the power supply for a motor as shown in Figure 2, electrical currents of

I_u , I_v , and I_w

flow through three lead wires. Each instantaneous value has waveform shown in Figure 1, and the sum of their instantaneous values at any arbitrary point is always zero.

The electrical power of this three-phase circuit is obtained by the following formula.

Three-phase alternating current electrical power
 $= \sqrt{3} \times \text{Line voltage} \times \text{Line current} \times \text{Power factor}$

$$P_3 = \sqrt{3} \times E \times I \times \cos \phi \quad [\text{W}]$$

$$P_{03} = \sqrt{3} \times E \times I \quad [\text{VA}]$$

where P_3 : Effective power [W], P_{03} : Apparent power [VA],
 $\cos \phi$: Power factor.

By multiplying the time, we get the electrical energy.

Three-phase alternating current electrical energy = Power x Time

$$P_h = P_3 \times t = \sqrt{3} \times E \times I \times \cos \phi \times t \quad [\text{Wh}]$$

where P_h : Electrical energy [Wh], t : Time [h].

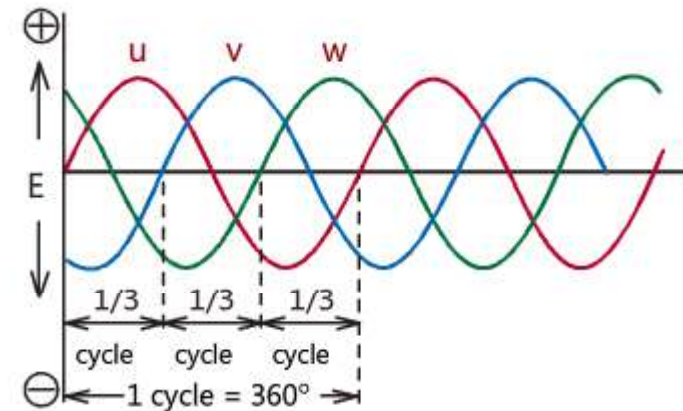

Fig.1 Voltage waveform

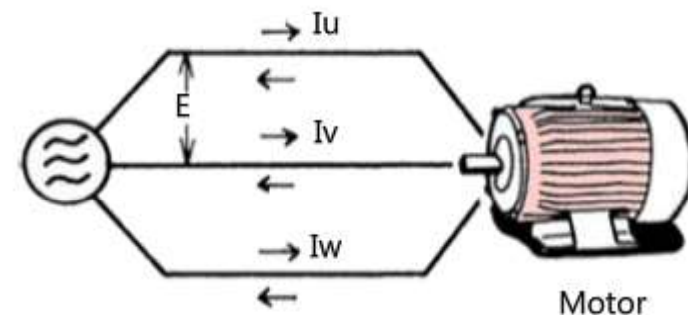

Fig.2 Motor circuit

1.8

Summary of this chapter



In this chapter, you learned the following points.

- **What is electricity** – Voltage, current, and resistance

- **Ohm's law**

The current I flows when the voltage E is applied to the resistance R . The size of such current is proportional to the voltage and inversely proportional to the resistance.

This can be written in either of these formulas: $I = \frac{E}{R}$ [A] or $E = I \times R$ [V]

- **Basics of alternating circuits**

Resistance, coils, capacitors, and impedance

- **What are electrical power and power factor**

Power = Voltage x Current

Power factor: $\cos \phi$

- **Electrical power and electrical energy in single phase circuits**

Effective power $P_1 = E \times I \times \cos \phi$ [W]

Electrical energy $Ph = P_1 \times t = E \times I \times \cos \phi \times t$ [Wh]

- **Electrical power and electrical energy in three-phase alternating current circuits**

Effective power $P_3 = \sqrt{3} \times E \times I \times \cos \phi$ [W]

Electrical energy $Ph = P_3 \times t = \sqrt{3} \times E \times I \times \cos \phi \times t$ [Wh]

Chapter 2 From power plant to consumer

Electricity is mainly produced in coal-fired power plants, nuclear power plants, and hydroelectric power plants, and is sent to factories and residential homes through various processes.

The electricity is used in factories and residential homes at 100 V or 200 V, while electricity is sent from power transformer substations outside of town via power distribution lines to telephone poles (pole-mounted transformers) at a higher voltage of 6600 V. If we look further upstream, the power transmission lines that link power plants to substations send electricity at the extremely high voltages of 60 kV, 275 kV, and even as high as 500 kV. High voltages are used in order to minimize the loss of the electrical power during transmission.

The loss of the electrical power (i.e. the amount of heat liberated by electrical resistance) is proportional to the square of the current. Therefore, the current can be reduced by raising the voltage, and it becomes possible to efficiently send electricity over limited diameter cables, while also being able to send more electricity (electrical power) over those cables proportionally to the voltage being used.

This chapter discusses how the electricity that is sent from power distribution substations is changed so that it can be used at 100 V or 200 V in factories and residential homes, and how it is made safe to use.

Coal-fired power plant, nuclear power plants, hydroelectric power plants

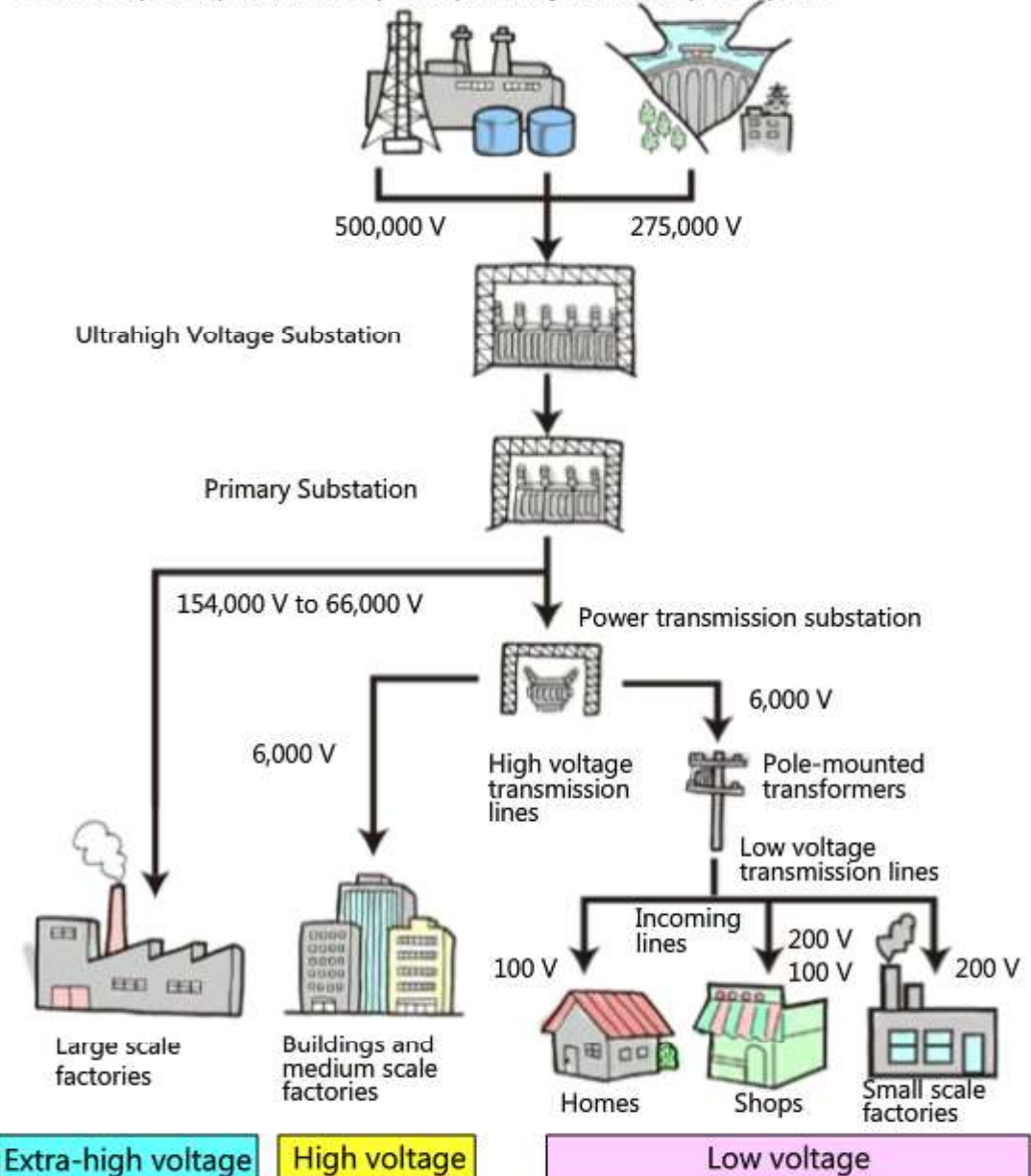

2.1

Voltage classifications and standard voltages (nominal voltages)

Voltages are divided into the three classes of low voltage, high voltage, and extra-high voltage as shown below.

- Low voltage: Direct current of 750 V or less or alternating current of 600 V or less
- High voltage: Direct current of 750 V or more or alternating current of 600 V or more, in either case being 7,000 V or less.
- Extra-high voltage: Voltages of 7,000 V or more.

The standard voltages (nominal voltages) of electric power transmission lines are specified in JEC 0222 as follows.

Chart A. Standard voltages of electric lines of 1000 V or more

Nominal Voltage [V]	
3300	110000
6600	154000
11000	187000
22000	220000
33000	275000
66000	500000
77000	

Chart B. Standard voltages of electric lines of 1000 V or less

Nominal Voltage [V]	
100	230/400
200	400
100/200	

Note: The representative line voltage of the electric line is called its nominal voltage.

2.2

Contracted power and received voltage



When a consumer receives supplied electrical power, the contracted power is classified as low voltage, high voltage, or extra-high voltage depending on its amount (wattage), and the necessary equipment and administration differ for each class as shown in the chart below.

Contracted Power	Received Power	Administration Method
Less than 50 kW	Low voltage (generally 200 V)	General use electrical equipment (Power company)
50 kW or more and less than 2000 kW	High voltage (6 kV level)	Private use electrical equipment (Can be subcontracted to a safety institute)
2000 kW or more	Extra-high voltage (includes some high voltages)	Private use electrical equipment (Chief engineer)

• Low voltage

Voltages of less than 50 kW are classified as low voltage. Pole-mounted transformers are used to step down the voltage of 6.6 kV to three-phase 200 V or single phase three-wire 100 V/200 V. Administration is handled by the power company.

• High voltage

Voltages of 50 kW or more and less than 2,000 kW are classified as high voltage. Private electrical equipment is installed and a chief engineer manages it. In this case, the chief engineer can be hired from outside. These voltages are the target of this course.

• Extra-high voltage

Voltages of 2,000 kW or more are classified as extra-high voltage. Private electrical equipment is installed and a chief engineer manages it. Note that the chief engineer must be chosen from among employees of the consumer.

2.3

Cubicle type high voltage power receiving equipment

High voltage receiving equipment is necessary to receive a high voltage power supply from the power company.

High voltage power can be received in the following ways:

- Installing a power receiving transformer outdoors and installing a switching panel indoors
- Installing both a power receiving transformer and a switching panel indoors
- Storing a power receiving transformer and a switching panel are in a cubicle

Cubicle type high voltage power receiving equipment is the equipment that stores the set of the receiving devices for incoming high voltages in a metallic case. It is also simply called a cubicle.

There is a recent trend to use "cubicle type high voltage power receiving equipment" for small to medium capacity power receiving equipment due to the following merits:

- Requires a little space
- No limitations on equipment location
- Highly reliable due to easy equipment installation and maintenance

The cubicle type high voltage power receiving equipment as specified by JIS C4620 is used for **circuits having the nominal voltage of 6.6 kV and the system short-circuit capacity of 12.5 kA, and applies to the receiving equipment having the receiving equipment capacity of 4,000 kVA or less.**



Cubicle type high voltage power receiving equipment

2.3 Cubicle type high voltage power receiving equipment

Cubicle type high voltage power receiving equipment is divided into the following classes based on the type of disconnecter devices. Cubicle types are specified in JIS C4620.

Type	Disconnecter	Receiving Capacity
CB type	Circuit breaker (CB)	4,000 kVA or less
PF-S type	Power fuse equipped load break switch (LBS with PF)	300 kVA or less

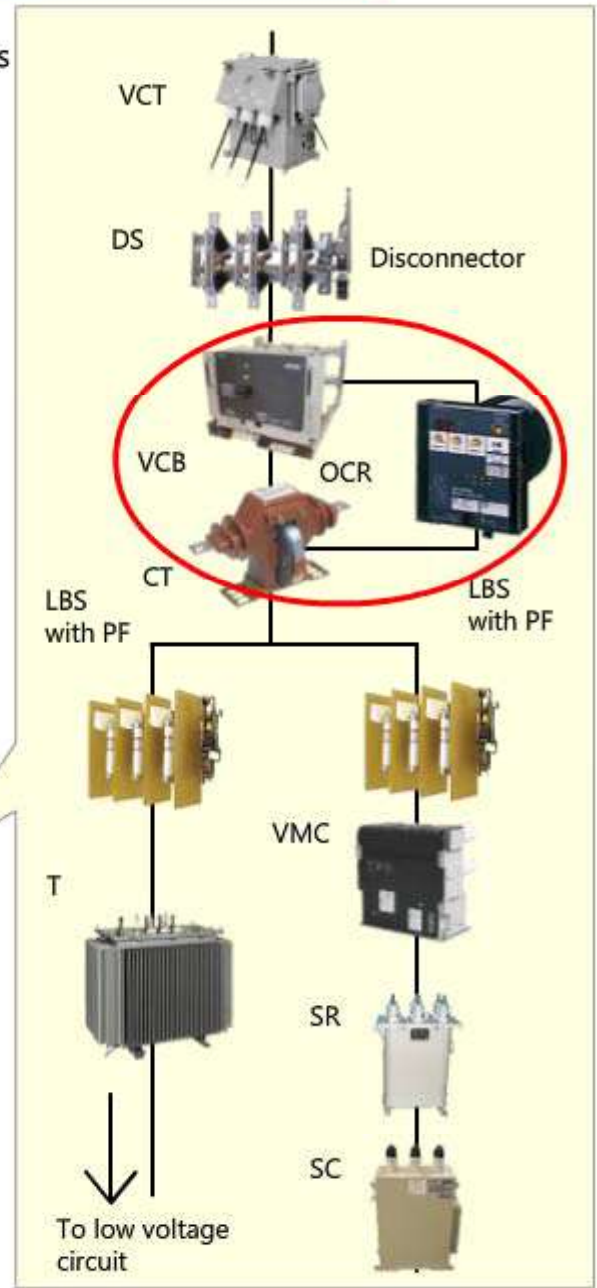
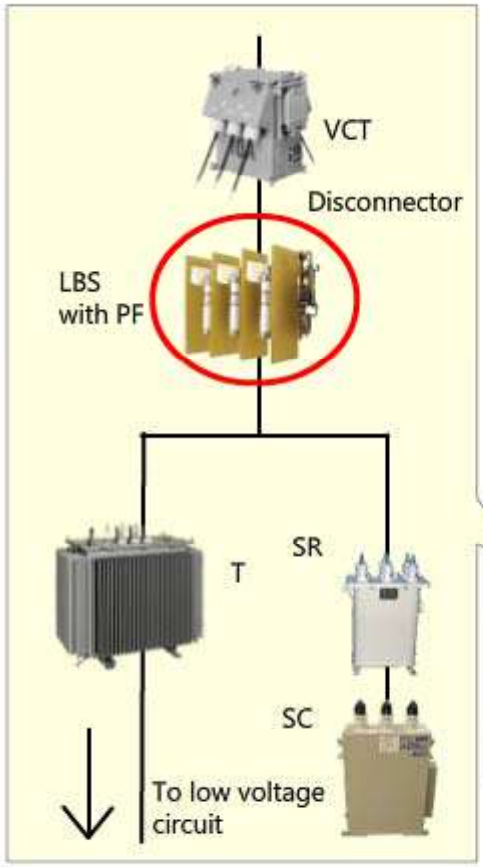

2.4 Skeleton

A skeleton is a type of single line diagram showing an electrical circuit diagram. The electrical circuits of a consumer's receiving equipment are illustrated with symbols being used to indicate devices such as disconnectors, isolators, transformers, measuring instruments, protective relays. This type of drawing uses single lines to indicate how each device is connected.

For example, the CB cubicle type high voltage power receiving equipment of Figure 1 is shown in a skeleton of Figure 2.

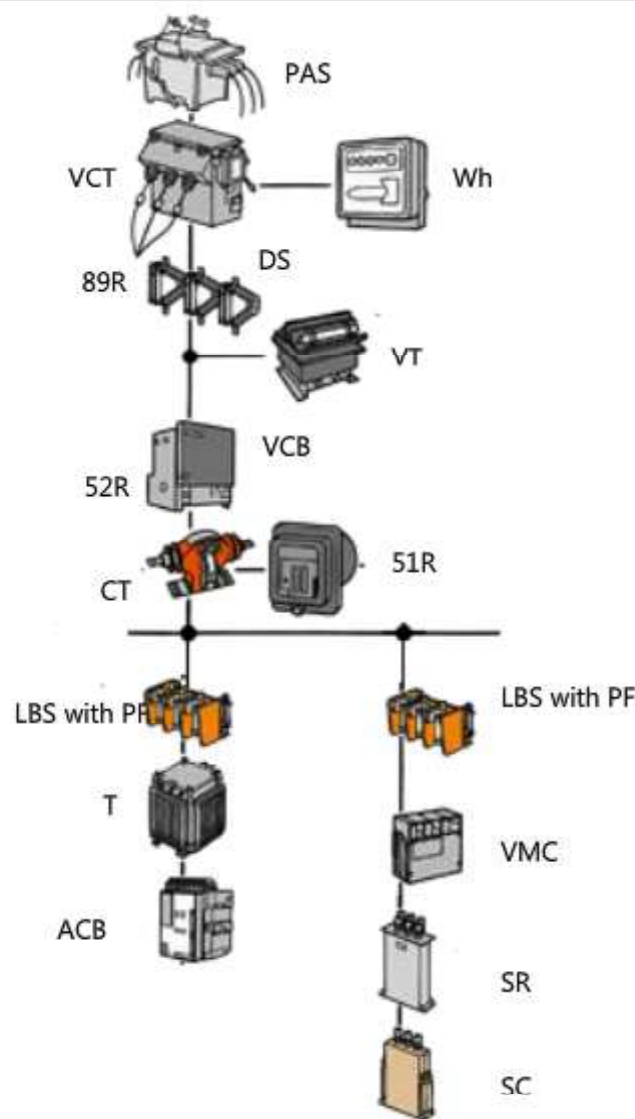

Fig.1
Cubicle type high voltage power receiving equipment

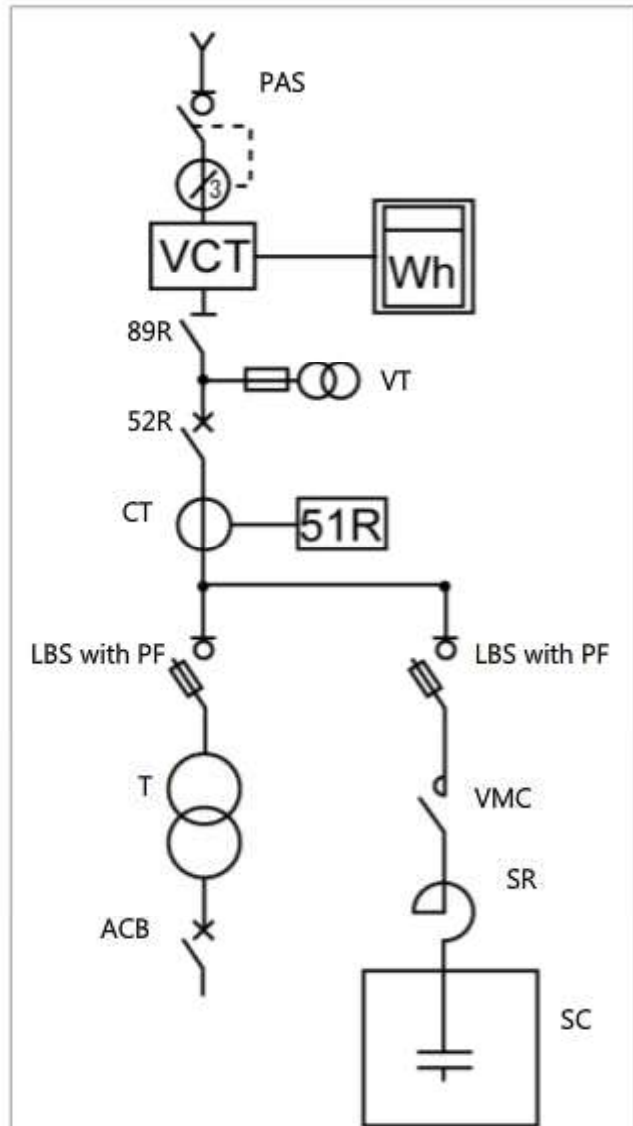

Fig.2
Skeleton (Single line connection diagram)

2.5

Symbol, Equipment Code, and Character Code



In a skeleton, individual devices are expressed using Symbol, Equipment Code, and Character Code.

- **Symbols**













Also called symbols. Electrical devices are illustrated as diagrams.

- **Equipment Code**

Electrical devices are shown as numbers.

- **Character Code**

Devices are abbreviated and shown as symbols. Many of them come from taking the first initial of the English name of the device.

Photo of Outer Appearance	Sketch	Name	Symbol	Equipment Code	Character Code	English Name
		Outdoor use air-break switch		—	PAS	Pole Air-Break Switch, or Pole-Mounted Air Switch
		Disconnecting Switch		89	DS	Disconnecting Switch, or Disconnecting Switch
		Vacuum Circuit Breaker		52	VCB	Vacuum Circuit Breaker
		Over Current Relay		51	OCR	Over Current Relay

Note: The photos of outer appearance show Mitsubishi Electric products and the sketch diagrams were created for this course.

2.6

Sequences



One of the types of electrical diagrams is the deployment connection diagram, which we will explain here.

This deployment connection diagram is also called a sequence, and it is used to show the electromagnetic switch control circuits of power distribution and control equipment, and so on.

In a sequence, the specified Symbol and Character Code are used to show various electrical devices and their components such as contacts, coils, resistance, and fuses. In addition, you should understand that a sequence is a connection diagram drawn simply to show the electrical connections according to the sequence of operation, and it has nothing to do with the actual position of the components.

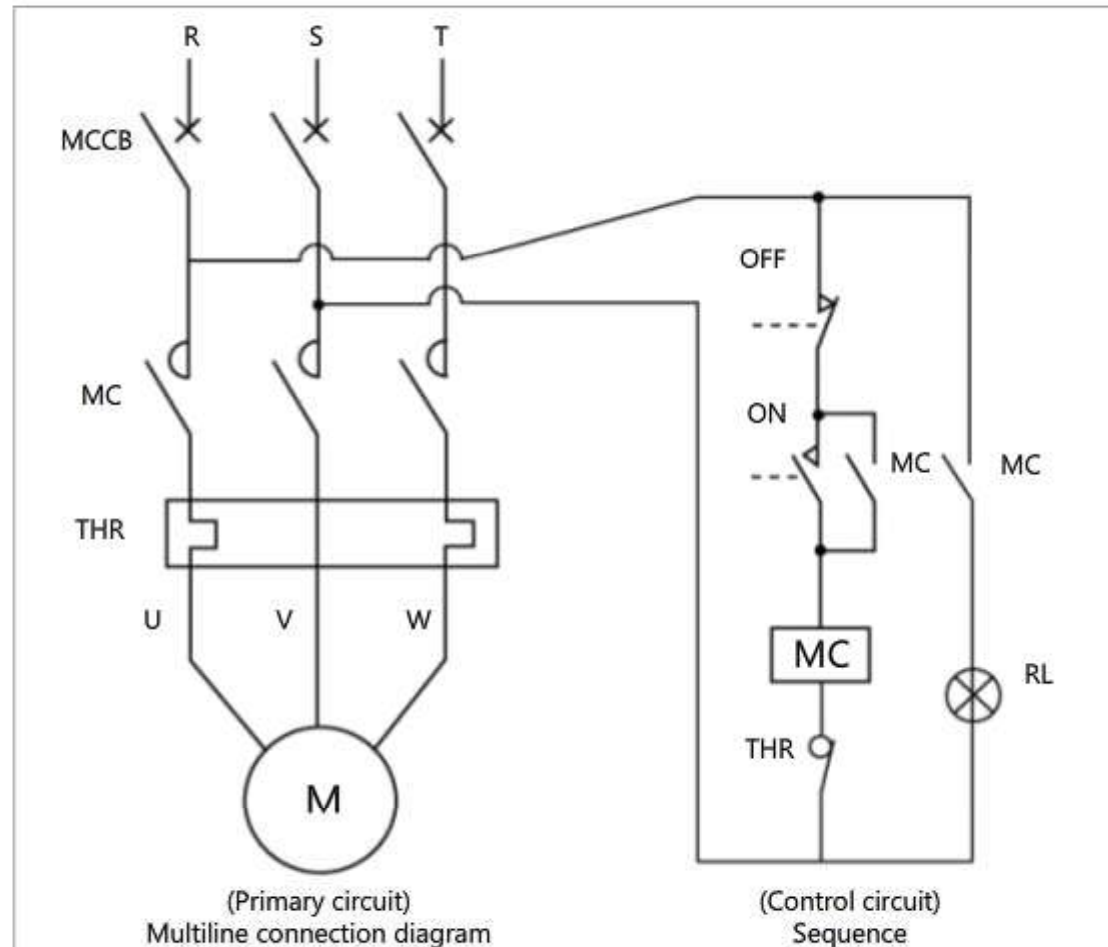
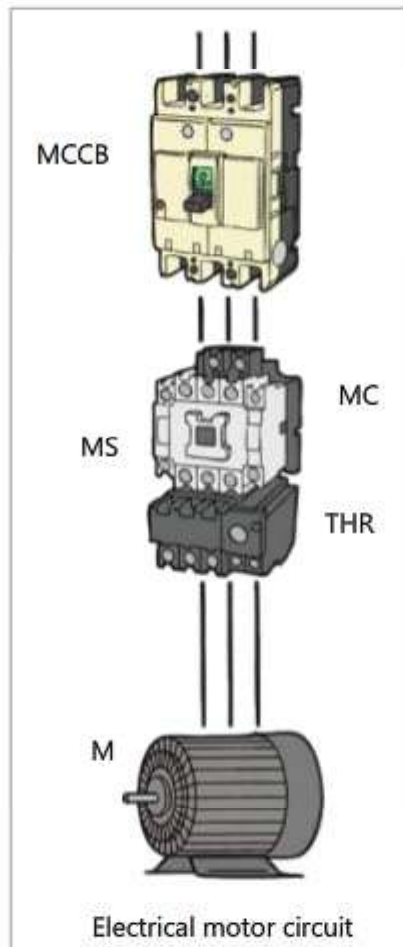

In this chapter, you learned the following points.

- The electricity used in factories and homes is sent from power plants at extremely high voltages such as 60 kV, 275 kV, and 500 kV.
- The electricity supplied to consumers is classified according to the amount of the contracted power (wattage) into the three classes of low voltage, high voltage, and extra-high voltage, and the required equipment and administration differ in each class.
- When electricity is supplied from the power company at high voltage, high voltage power receiving equipment is necessary. Recently, there is a trend to use the cubicle type high voltage power receiving equipment.
- Cubicle type high voltage power receiving equipment is divided into the classes of CB type (4,000 kVA or less) and PF-S type (300 kVA or less) based on the type of the disconnecter device.
- A skeleton is a type of single line drawing showing an electric diagram. The electrical circuits of a consumer's receiving equipment are illustrated with symbols being used to indicate devices such as disconnectors, isolators, transformers, measuring instruments, protective relays. This type of drawing uses single lines to indicate how each device is connected.
- In a skeleton, individual devices are expressed using Symbol, Equipment Code, and Character Code.
- One kind of electrical circuit diagrams is the deployment connection diagram, also known as a sequence, which is used to show the control circuits of the electromagnetic switch of power distribution and control equipment, and so on.
- In a sequence, the specified Symbol and Character Code are used to show various electrical devices and their components such as contacts, coils, resistance, and fuses. In addition, you should understand that a sequence is a connection diagram drawn simply to show the electrical connections according to the sequence of the operation, and it has nothing to do with the actual position of the components.

Chapter 3 Power distribution and control equipment

Power distribution and control equipment includes high voltage power receiving equipment, as well as devices for low voltage circuit such as low voltage circuit breakers and electromagnetic switches. In this chapter, we divide power distribution and control equipment into the following four categories and explain them separately.

- (1) High voltage equipment
- (2) Measuring instruments
- (3) Low voltage circuit breakers
- (4) Electromagnetic switches

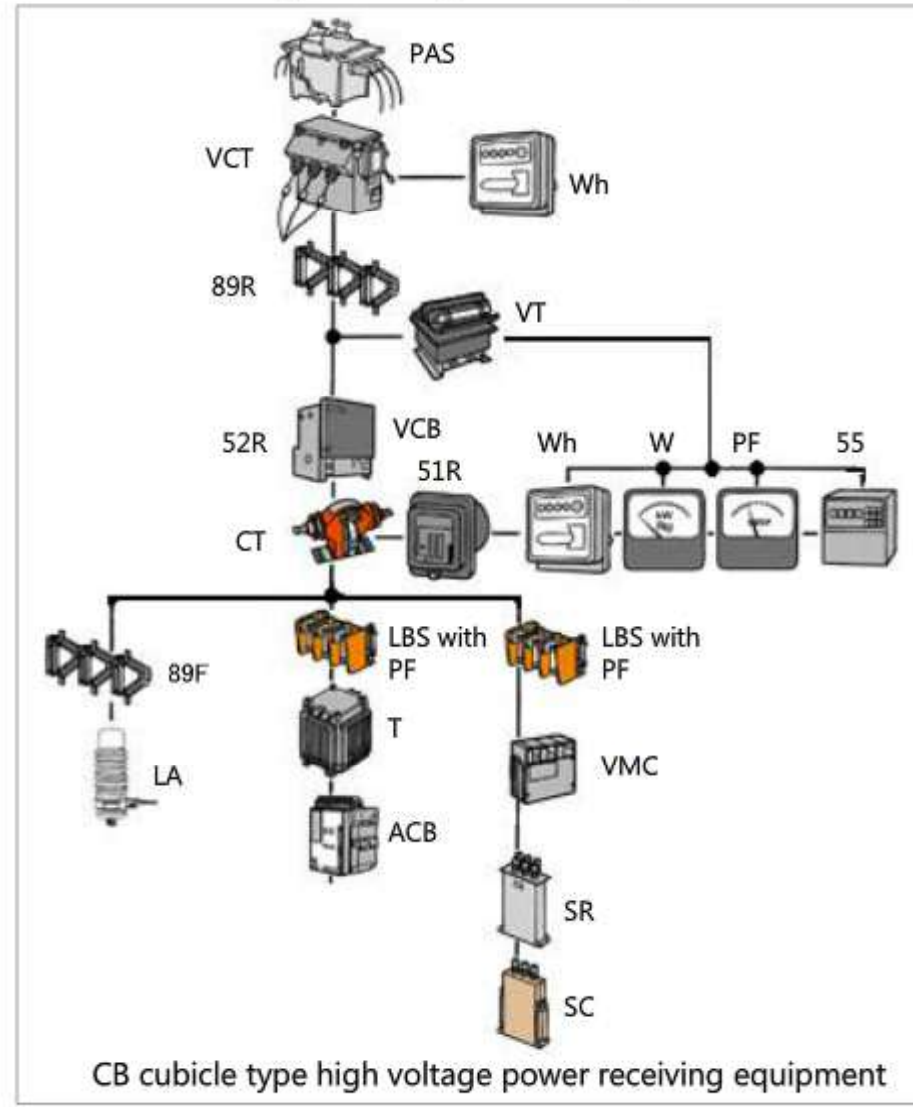
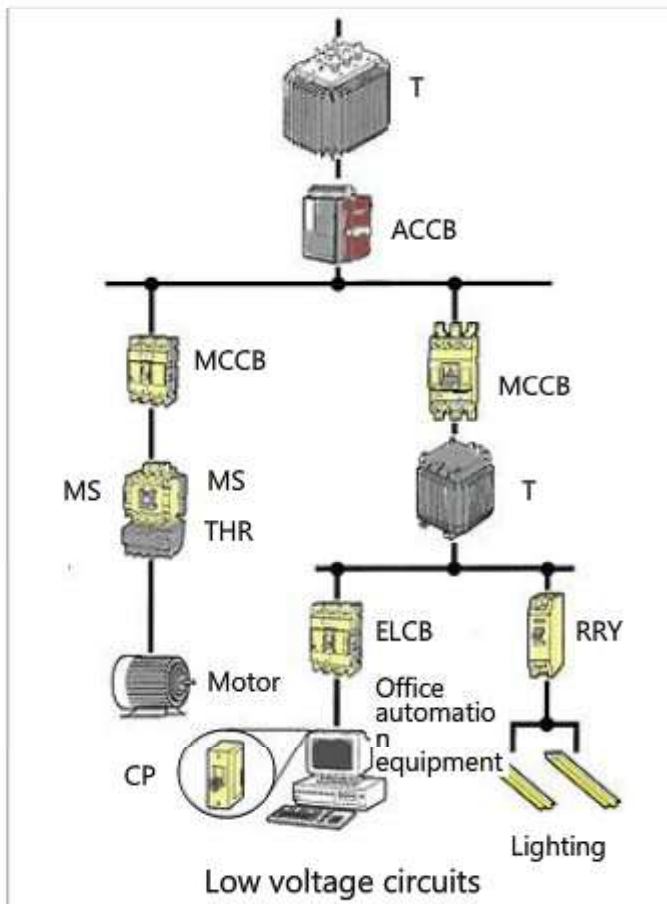

3.1 High voltage equipment

Here we discuss the power distribution and control devices used in cubicle type high voltage power receiving equipment.

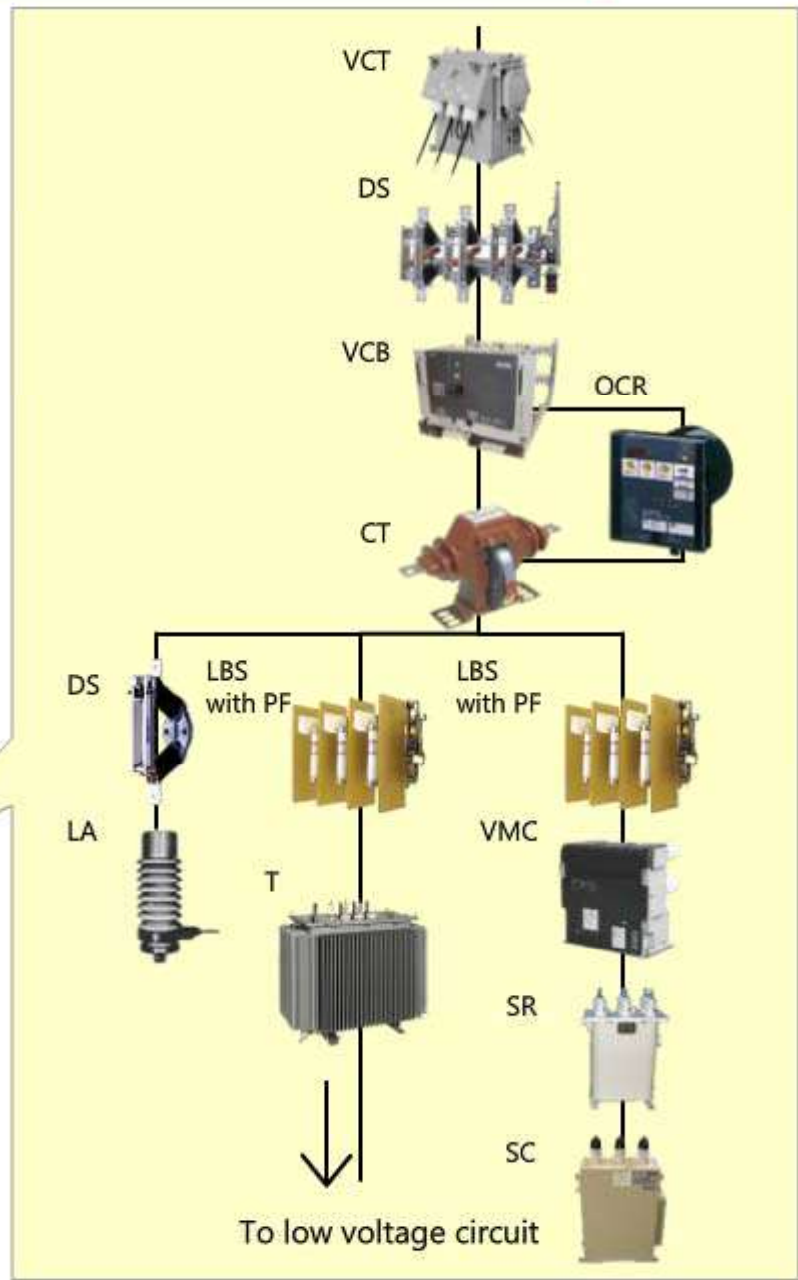

3.1

High voltage equipment



Below are the types of the high voltage equipment used in the cubicle type high voltage power receiving equipment.

(1) Pole-mounted Air Switch (PAS)

Also called Pole Air-Break Switch. This device is placed on the border between the power company and the consumer, which is called the responsibility demarcation point. In case of an accident occurring within the consumer's area of responsibility, the device automatically breaks the circuit using the signal from the SOG (Storage Overcurrent Ground) control device, disconnecting the circuit from the power company's transmission line in order to avoid the accident from spilling over the other power grid. Also called a zone switch.

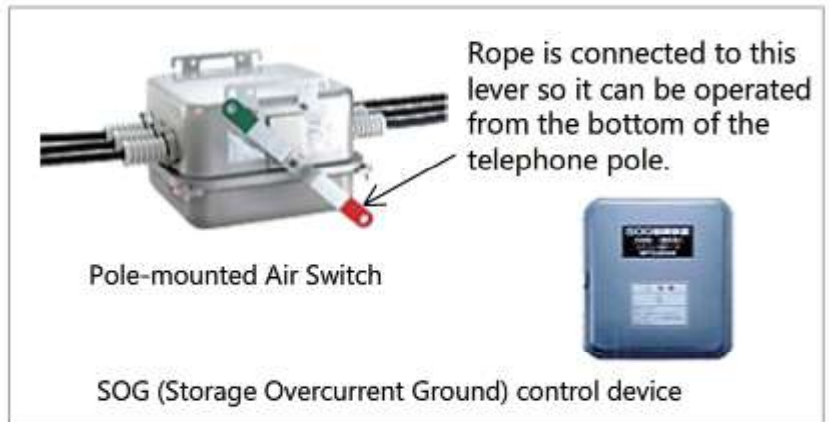

(2) Combined Voltage & Current Transformer (VCT)

Includes an instrument voltage transformer (VT) and current transformer (CT). A VCT belongs to the power company, but it is installed inside a cubicle. It measures the amount of power consumed, and is used to calculate electricity usage fees.



(3) Disconnecting Switch (DS)

Also called a disconnecter. This device is used to completely turn off all electricity in a consumer's area in order to perform the electrical maintenance within that zone.



3.1

High voltage equipment

**(4) Current Transformer (CT)**

A current transformer changes the primary circuit current of from several amperes to several hundreds amperes to the 5 A input level used by protective relays and measuring instruments.

In CB-type installations, it is used as a current sensor, and in case of a malfunction, the protective relay recognizes the abnormality of the current and sends a trip signal to a vacuum circuit breaker to break the circuit.

(5) Over Current Relay (OCR)

An over current relay decides whether or not there has been a malfunction based on the current from a current transformer, and if there has been a malfunction, it sends a trip signal to a vacuum circuit breaker, protecting the circuit by tripping the breaker.

Relays other than OCR include under voltage relays (UVR), ground relays (GR), directional ground relays (DGR), and so on.

(6) Vacuum Circuit Breaker (VCB)

Electrical current is switched on and off at a contact in a vacuum bulb. In case of malfunction, it receives a trip signal from an over-current relay or other devices and break the circuit.

In CB-type installations, the devices numbered (4) through (6) above are combined and operate to protect the circuit when an excess current flows due to an electrical overload, short circuit, or other accidents.



Current transformer



Vacuum circuit breaker



Protective relay

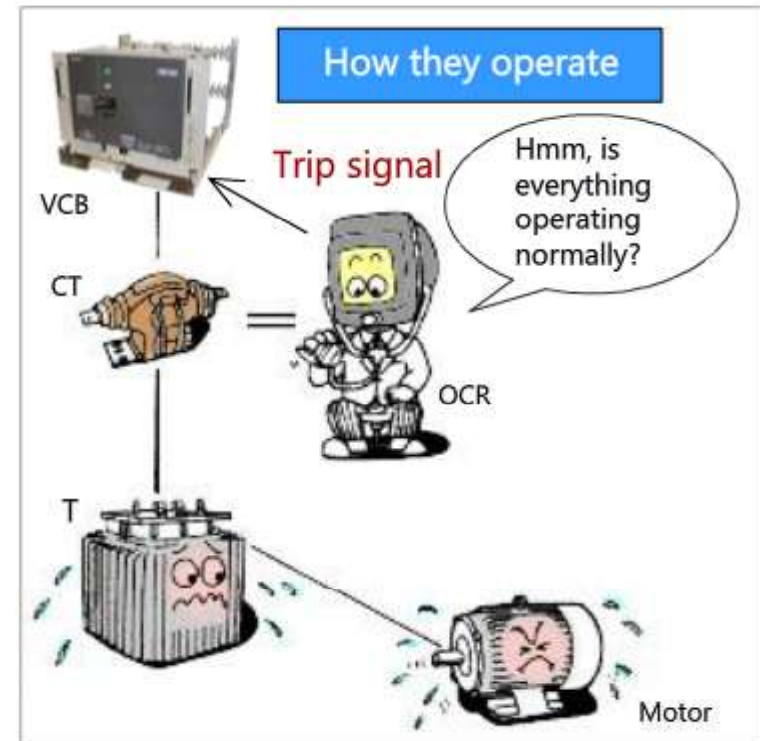

3.1

High voltage equipment



(7) Load Break Switch (LBS)

A load break switch can turn on and off an electrical current or pass an electrical current.

It is usually used with power fuses, and is called power fuse equipped load break switches (LBS with PF).

Power fuse equipped load break switches, due to the characteristics of a fuse, are used for voltage transformer protection, capacitor protection, and motor protection.

PF-S cubicle type high voltage power receiving equipment uses them as the primary circuit breaker device.



Power fuse equipped load break switch (Without barriers)



Power fuse equipped load break switch (With barriers)

(8) Power Fuse (PF)

In case of a short circuit accident, the fuse element in the power fuse melts to break the circuit, thereby preventing equipment and electrical wiring from being burnt.



Electrical Power Fuse

(9) Transformer (T)

Transformer converts high voltages such as 6.6 kV to low voltages such as 100 V / 200 V / 400 V.

There are transformers for both single phase and three-phase.



Oil transformer
Three-phase 500 kVA 50 Hz



Mold transformer
Three-phase 500 kVA 50 Hz

3.1

High voltage equipment



(10) Vacuum Electromagnetic Contactor (VMC)

Similar to a vacuum circuit breaker, this device switches on and off an electrical current with a vacuum bulb.

An electromagnet operation opens and closes a contact, so it has a long lifetime and can turn on and off motors and capacitors frequently.



Vacuum electromagnetic contactor

(11) Static Capacitor (SC)

A static capacitor is used to advance a phase in an alternating current circuit.

The inductive load in devices such as motors and electrical furnaces is a lagging power factor. An SC is used to improve such power factor and bring the power factor closer to 1.

When you improve the power factor, you can receive a discount on your monthly contracted basic fee.



Oil-filled static capacitor



Gas-filled static capacitor

(12) Series Reactor (SR)

A series reactor is installed in series with a static capacitor and reduces the voltage distortion caused by high frequencies in a circuit. It protects capacitors by limiting an inrush current when a capacitor is turned on.

The above devices (10) through (12) are combined to improve power factors.



Oil series reactor



Mold series reactor

3.1

High voltage equipment



(13) Surge Arrester (SAR)

Also called a Lightning Arrester (LA).

This device protects electric devices such as motors and transformers, to which a voltage is always applied, from burning or blackout caused by an abnormal high voltage generated by a lightning strike or other incidents.

Equipment is protected from an abnormal voltage by discharging it via a surge arrester.

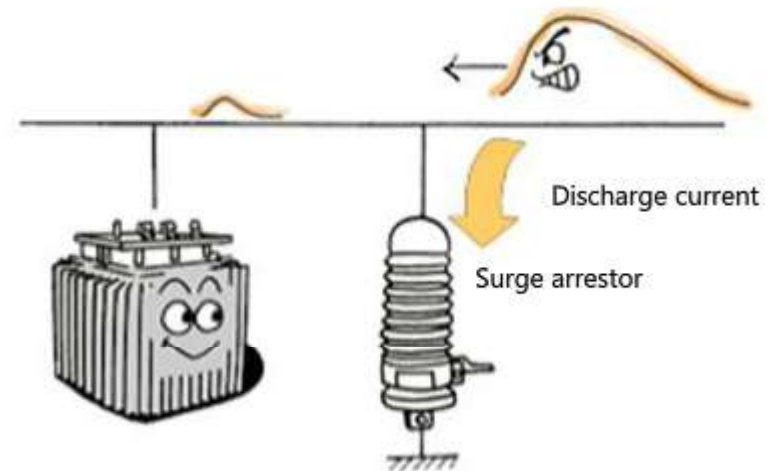

Side Note

Lightning conductor

A lightning conductor is used to be hit by a direct lightning stroke to prevent other buildings from being struck by lightning.



3.2

Measuring instruments



When using electricity, it is necessary to measure the amount of electricity and to understand how much has been used.

However, electricity itself cannot be seen by the human eye. Various measuring instruments are used to make it visible and measure the amount to manage it.

Measuring instruments, also called gauges, can be used to measure both low and high voltages. Mitsubishi Electric classify them as low voltage instruments.

Measuring instruments are mainly used for:

- ▶ **Detecting** (instrument transformers)
 - **Quantitating** (power meters)
 - **Measuring** (electrical indicating meters, transducers)

Additional usage includes:

- **Improving quality factor** (automatic power factor adjuster)
- **Managing contracted electrical power** (demand monitoring and control devices)

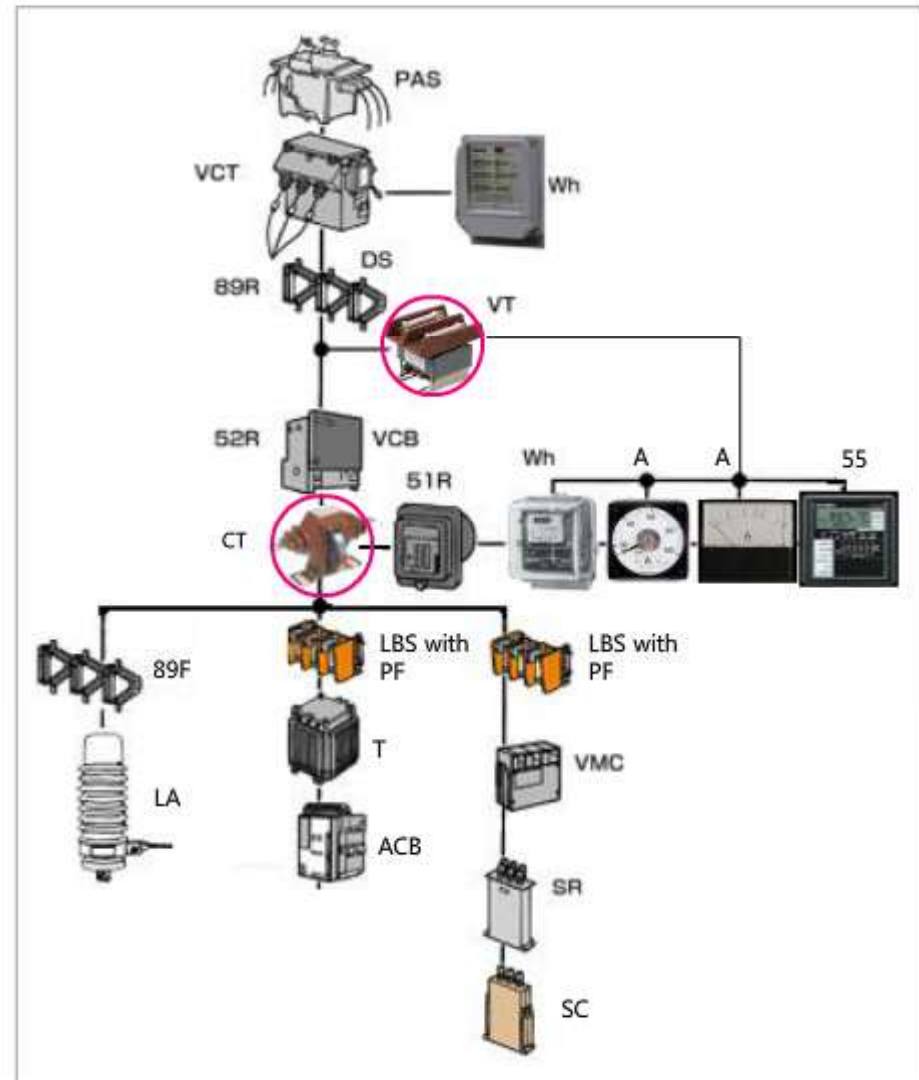

3.2

Measuring instruments



Instrument transformer is a general term that covers measuring instrument voltage transformers and current transformers. It is used to safely and accurately measure high electrical voltages and large electrical currents.

(1) Voltage Transformer (VT)

A voltage transformer is used to measure high electrical voltages. It converts 6.6 kV to 110 V.



Measuring instrument voltage transformer

(2) Current Transformer (CT)

A current transformer is used to measure large electrical currents. It converts from several tens to several hundreds of amperes to 5 A.



Current transformer

(3) Watt-Hour Meters (WHM)

A watt-hour meter is used to measure the amount of electrical power.

There are both mechanical and electronic types of WHM.



Mechanical watt-hour meter



Electronic watt-hour meter



Surface type electronic watt-hour meter

3.2

Measuring instruments



(4) Indicated Electricity Meter (M)

Also simply called a meter, this device measures and displays electrical quantities such as voltages and amperages.

For example,

voltage is measured by a voltmeter (V),

current (amperage) is measured by an ammeter (A),

power is measured by a wattmeter (W), and

power factor is measured by a power-factor meter (PF).

Using mechanical and electronic type multi-indicator meters, various types of electrical quantity can be measured.



Voltmeter



Ammeter



Electronic multi-indicator meter

(5) Transducer (TD)

An electrical signal, either alternating current or direct current, which is then converted into the proportional direct voltage or direct current, is input to a transducer, and then it is output to a monitoring and control device such as an indicator gauge or a computer.



Transducers

3.2

Measuring instruments



(6) Automatic Power Factor Controller (APFC)

This device outputs a signal that can automatically turn on or off a static capacitor, in order to keep the power factor within target limits.



Automatic power factor controller

(7) Demand Meter (DM)

A demand meter is a device for monitoring and controlling a demand.

Demand means the average amount of electrical power used over 30 minutes.

Let us consider the case of a consumer subscribing to an electrical usage fee system which charges for the actual amount used based on a contracted power of less than 500 kW. In this case, should the demand value end up exceeding the contracted electrical power, then such demand value is regarded as the contracted power over the following year, and the consumer must pay for more electrical usage fee.

Demand meters compute the predicted demand and output alerts or load control signals in order to manage the demand value to be kept within the amount of contracted power.

Demand meters include those of the DEMACON series and the web-enabled E-Energy Series demand monitoring servers.



Demand meters (DEMACON series)



Web-enabled demand monitoring server (E-Energy series)

(8) Time Switch

This device is a switch combined with a clock. The switch turns on or off at a preset time.



Time switch

3.3

Low voltage circuit breakers

Low voltage circuit breaker is a general term that covers circuit breaker devices used mainly for the purposes of protecting wiring and equipment in low voltage circuits.

Low voltage circuit breakers include:

- MCCB (molded case circuit breakers) for wiring
- ELCB (earth leakage circuit breakers)
- ACB (low voltage air circuit breakers)
- Remote controlled devices such as RRY (remote controller relays)
- CP (circuit protectors)

Mouseover the product to view enlarged images.

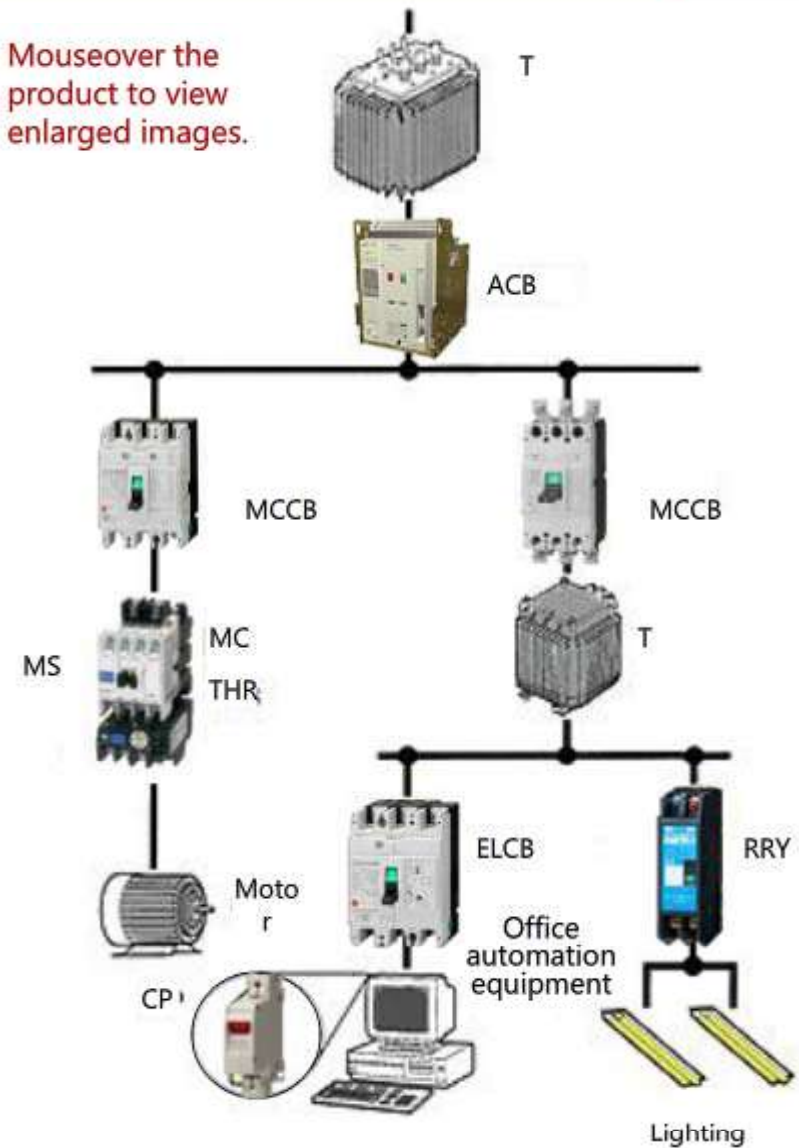

Low voltage circuits

3.3

Low voltage circuit breakers



(1) Molded Case Circuit Breaker (MCCB)

This device protects wirings from overload and short circuit malfunctions.



No-fuse breaker



No-fuse breaker for distribution boards



BL-type safety breaker

(2) Earth Leakage Circuit Breaker (ELCB)

An ELCB protects against electric shock, earth leakage, and damage to wirings in case of accidents or malfunctions such as overloading, short circuits, and ground faults.



Earth leakage circuit breaker



ELCB for distribution boards



Safety breaker type ELCB

3.3

Low voltage circuit breakers

**(3) Air Circuit Breaker (ACB)**

An ACB is used in buildings, factories, and marine vessels. The two main types are for electrical circuit protection and for electrical generator protection.

An ACB is a master circuit breaker that is of larger scale than MCCB.



Buildings and factories



Marine vessels



AE1600-SW type air circuit breaker

(4) Remote control devices

These are devices used for centrally controlling at a distance (remote controlling) the turning on and off of lighting in buildings, schools, hospitals, and other locations.

These devices are composed of remote control relays, remote control breakers, remote control earth leakage circuit breakers, remote control switches, and remote control transformers.



Remote control breaker



Remote control earth leakage circuit breaker



Remote control relay



Remote control transformer



Remote control switches

(5) Circuit Protectors

These devices include circuit protectors (CP) and circuit breakers for equipment (CBE).

They are ultra-small circuit breakers having switch functions and fuse protection characteristics to protect equipment.



Circuit protector

3.4

Electromagnetic switches



The manufacturing equipment and various machines and devices in factories use many different motors. These motors are turned on and off and protected by electromagnetic switches.

(1) Electromagnetic Switch (MS)

These devices are made by combining electromagnetic contactors and thermal relays.

The main types are irreversible, which can run a motor only in a single direction, and reversible, which can run a motor in both forward and reverse directions.

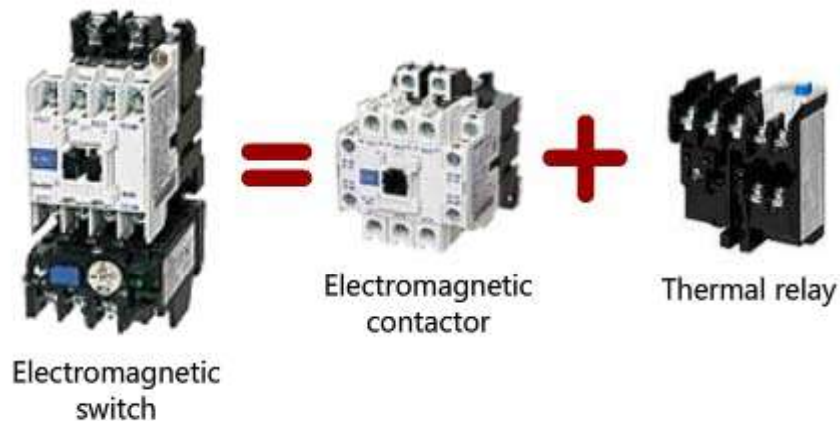

Electromagnetic switches are used for the following purposes:

- Start and stop motors
- Prevent motor from being burnt

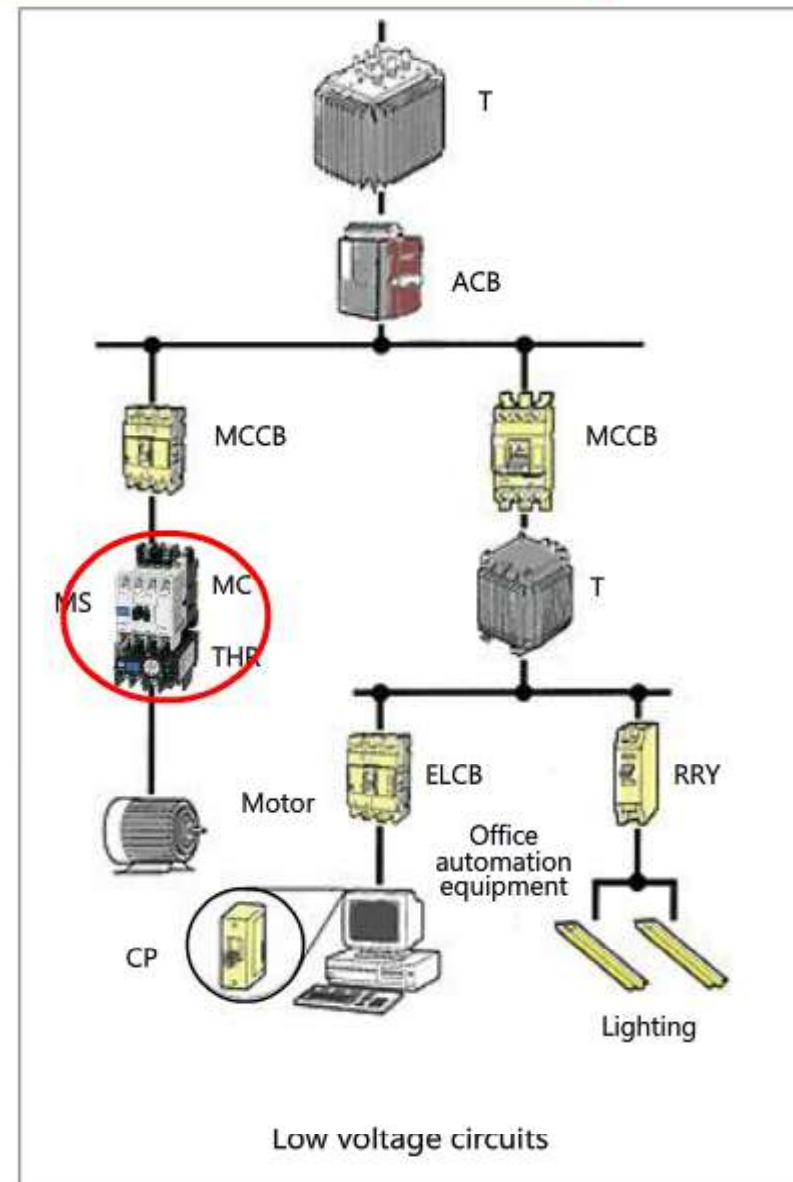

3.4

Electromagnetic switches



(2) Electromagnetic Contactor (MC)

These devices open and close contacts through the operation of an electromagnet, and therefore they have a long lifetime and can be used for frequent opening or closing such as an operation of a motor.

These devices include high sensitivity contactors that can be controlled by the transistor output of sequencers and contactless solid state contactors.



Electromagnetic contactor



High sensitivity contactor



Solid state contactor



Solid state contactor

(3) Thermal Relays (THR)

These devices are used most prevalently to protect motors against overloads. In case of overload, the bimetal responds to the heat caused by an excess electrical current and opens an internal contact. This action stops the excitation of a coil connected to that contact, opening an electromagnetic contactor and thereby protecting the motor.



Thermal relay

3.5**Summary of this chapter**

In this chapter, you learned the following points.

- Mitsubishi power distribution and control equipment is classified into high voltage devices, measuring instruments, low voltage circuit breakers, and electromagnetic switches.
- High voltage devices are primarily used in cubicle type high voltage power receiving equipment, and include pole-mounted air switches (PAS), combined voltage and current transformers (VCT) for power supply and receiving, disconnectors (DS), current transformers (CT), over-current relays (OCR), vacuum circuit breakers (VCB), power fuse equipped load-break switches (LBS with PF), power fuses (PF), transformers (T), vacuum electromagnetic contactors (VMC), static capacitors (SC), series reactors (SR), and lightning arrestors (LA).
- In addition to combined voltage transformer and current transformers (VT, CT), watt-hour meters (WHM), indicated electricity meters (M), and transducers (TD), measuring instruments also include automatic power factor controllers (APFC), demand meters (DM) for monitoring and control, and time switches (TS).
- Low voltage circuit breakers include molded case circuit breakers (MCCB) for wiring, earth leakage circuit breakers (ELCB), air circuit breakers (ACB), remote controlled devices such as remote controller relays (RRY), and circuit protectors (CP).
- Electromagnetic switches (MS) are made by combining electromagnetic contactors (MC) and thermal relays (THR).

You have completed the **FA Equipment for Beginners (Power Distribution Control Products)** Course.

Thank you for taking this course.

We hope you enjoyed the lessons and the information you acquired in this course will be useful in the future.

You can review the course as many times as you want.

Review

Close