



FA Equipment for Beginners (PLCs)

This is a quick overview of PLCs for beginners.



Introduction Purpose of the Course



This is an introductory course designed to provide beginners, who are new to PLCs, an opportunity to learn the basics of PLCs.

Introduction Course Structure



Chapters of this course are made up as follows.
We recommend that you start from Chapter 1.

Chapter 1 - Sequence Control

Learn about the basics of Sequence Control: including the meaning of the term "sequence".





Chapter 2 - PLC

Learn about the basics of PLCs: including history, roles, advantages.

Final Test

Passing grade: 60% or higher.

Introduction **How to use this e-Learning Tool**

Go to the next page		Go to the next page.
Back to the previous page		Back to the previous page.
Move to the desired page		"Table of Contents" will be displayed, enabling you to navigate to the desired page.
Exit the learning		Exit the learning. Window such as "Contents" screen and the learning will be closed.

Introduction **Precautions for Use****Safety Precautions**

If actually using any of the products while taking this course, please read through the Safety Precautions in the manual for the product being used and take all necessary safety precautions to ensure that you are using the product in a proper manner.

Chapter 1 Sequence Control

1.1 Meaning of "Sequence"

If you look up the meaning of "sequence", you will find it has the following meanings.

- (1) Consecutively occurring : succession, linkage, successive occurrence
- (2) Order of things : rank order, order, progression
- (3) Transition of things : order, natural result

The term "sequence" has also come to be used in association with computers and telecommunications, basically refers to a continuous operation procedure in accordance with rules and regulations.

From this, we can infer that the term "sequence control" refers to causing a target to operate as intended in accordance with a predetermined order and conditions.

Definition of Sequence Control

"Control that progresses in stages in a predetermined order"

Sequence control frequently exists in our daily lives.

1.2

Familiar Forms of Sequence control



Automatic car-washing machines at gasoline stations operate in an established order.



Insert money and
press the start button.

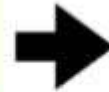

The car is washed with
water.



The dirt is removed
with detergent.



The car is dried.



The car is rinsed with
water.



The car is mopped.

Thus, sequence control can be seen in familiar car-washing machines.

1.2

Familiar Forms of Sequence control



Car Wash Example

Now let's take a look at specific types of control in the example of a car-washing machine.

Actions are processed in an established order according to conditions such as "button pressed," "time elapsed," and "previous action completed."

Click the "Play" button to check the actions of the car-washing machine.

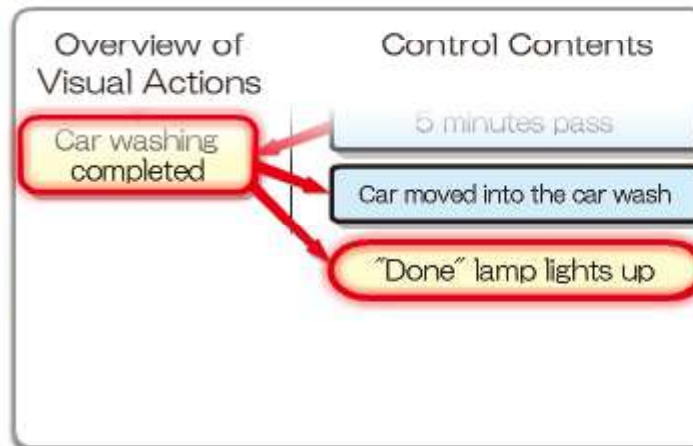

A "Done" lamp lights up at the end to inform the user that the car wash cycle has finished.



1.3

Advantages of Sequence Control



Sequence control is widely used especially in factories.

Many operations and tasks are automated by sequence control. Tasks, dangerous and simple, that used to be performed by people are now performed by machines so people can focus on safe tasks. Machines are also not subject to fatigue.

While people are taking a break, products continue to be produced by accurately performing a series of predetermined actions even in environments that are too harsh for people to work in.

Consequently, machines have made it possible to efficiently mass-produce high quality manufactured goods.

This streamlining of the production process is known as "factory automation", or "FA".

Thus, sequence control plays an important role in FA.

Process/Task Example	Sequence Control Usage Examples
Sorting	Size of products on a belt conveyor in a production line is determined and then are sorted.
Cutting	Length of materials in rolls is measured and cut by a cutter mobilized at fixed intervals.
Bottling Liquids	Empty bottles are transported to position below the nozzle, filled with a certain amount of liquid, then transported to another position. The next empty bottle is then transported.
Retooling	Products are counted and when the necessary amount is reached, the robot is instructed to produce a different product.
Monitoring	The amount of liquid is monitored; if the fixed amount is about to exceed, the bottle will be discharged and a lamp lights simultaneously to warn the human operator.
Part Change	Barcode label applied to the product is read and machine is instructed to change which parts are to be mounted according to where it will be exported.

1.4

Basic Sequence Control



Basic sequence control is produced through a combination of the following.

- Sequential control
- Conditions control
- Time limit control / counting control

(1) Sequential control

Sequential control operates apparatus in an predetermined order, and is also known as "step control".

The flow described in section 1.2 involving a car-washing machine, where you insert money, press the start button, and the car is then washed with water, washed with detergent and then mopped is a form of sequential control.

Machinery usually operates by some sort of predetermined sequence.

Sequential control, in the case of machinery, controls the sequence of actions that the machinery performs. The following describes "conditions control," which determines by what conditions the machinery will operate or stop.

Sequential control

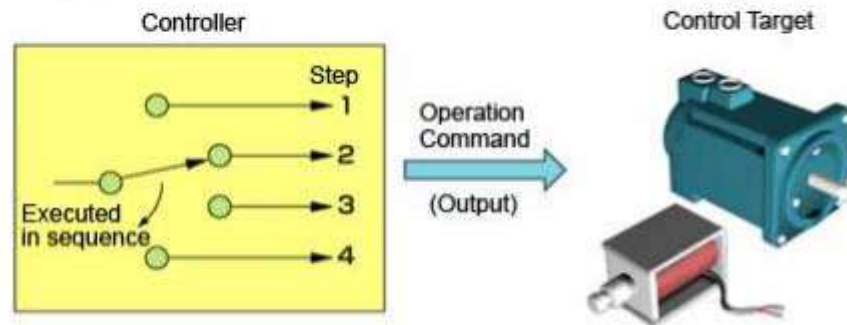

1.4

Basic Sequence Control



(2) Conditions control

Conditions control is a type of control where equipment is operated when predetermined conditions are met by combining status signals and completion signals.

This is also called "interlock control" because conditions are applied by combinations of signals so the apparatus only operates when necessary.

With the type of control used in the example of a car-washing machine in section 1.2, the car being washed when money insertion is detected and the button is pressed is an example of conditions control.

As shown in the following figure, if the controller is regarded a black box, the status/completion signals from the target of control becomes "input" and the command signals to the target become "output".

"Output" is determined by "input" conditions, which operates the control target. The signal from the control target will become the next "input".

Thus, with conditions control, a loop is created between the control equipment and the target of control by status/completion signals and command signals.

Conditions Control

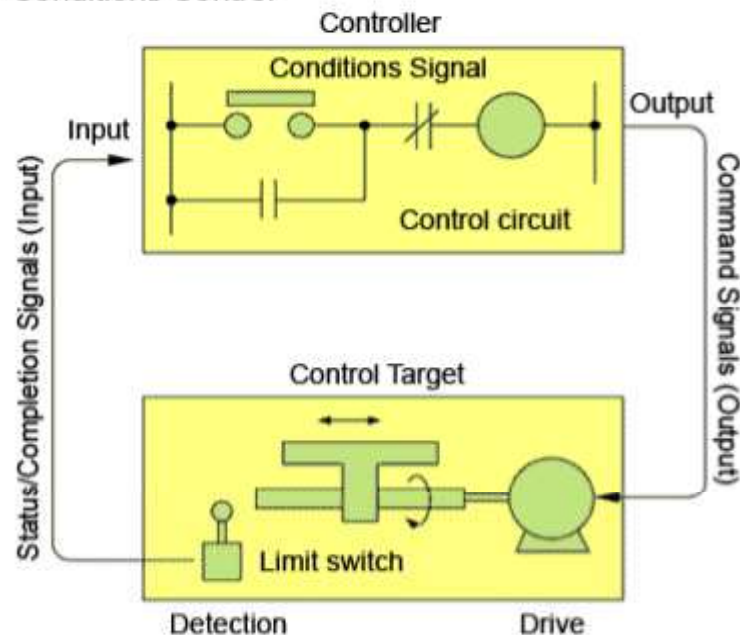

1.4

Basic Sequence Control



(3) Time limit control / counting control

"Time limit control" is a type of control whereby the operation commands to the target of control are determined by time of day and elapse time.

With the car-washing machine control described in section 1.2, step 2 (initial washing with water), for example, is performed and when the operation completes it proceeds to the next step (step 3). This corresponds to time limit control.

Counting control is similarly a type of control whereby actions that impact the target of control are determined by counting such as number of products or number of times machinery performs a certain action.

Time limit control requires a timer function and counting control requires a counter function.

Time Limit Control

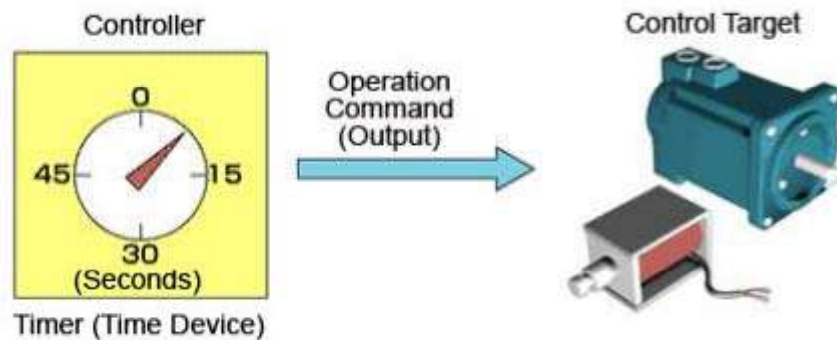

Counting control

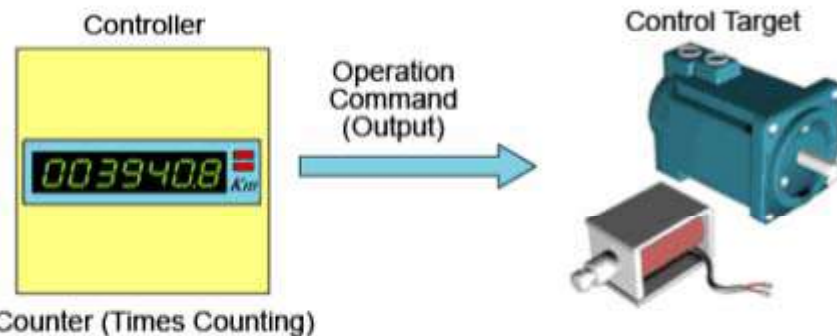

1.5

Systems that Function Using Sequence Control



It's basically the same principle.

<Human Beings>

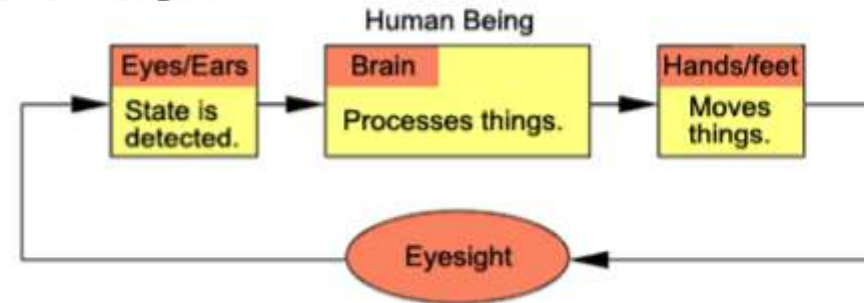

<Machine>

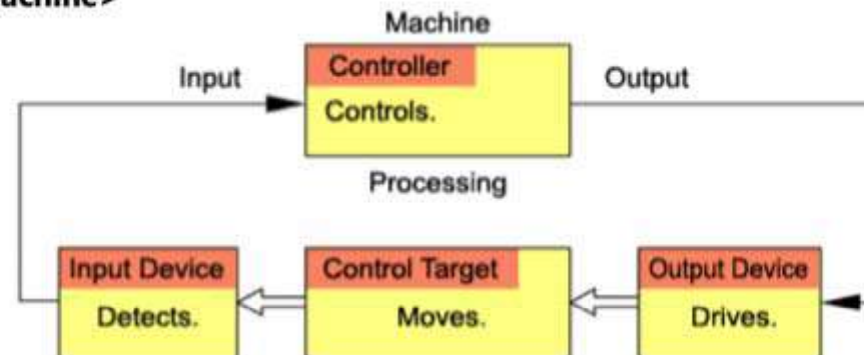

Input Device: Device operated by human being (start/stop switch, etc.).

Device that detects status of machine (position limit switch, proximity switch, etc.).

Output Device: Device that moves machine (motor, solenoid valve, etc.)

Devices that inform human operator of status of machine (indicator lamps, warning buzzer, etc.)

1.5

Systems that Function Using Sequence Control



Basic Knowledge of Contacts

(1) Contacts

Contacts can stop or allow flow of electricity by opening/closing.

Electrical parts such as switches, relays, timers and counters are equipped with contacts.

Timers and counters, which are internal parts of PLCs, can also be thought as a type of contact, rather than an actual electrical component.

(2) a Contact

Normally, an open contact closes when provided a command.

Here, "commands" refer to operation commands. In the case of a pushbutton, the act of pressing the button is the equivalent of a command.

The term "a contact" comes from the first initial of "arbeit contact" (working contact). It is also known as a "normally open contact".

Operation (Pushbutton Switch)

Contact is open as long as the pushbutton switch is not pressed and closed when pressed.

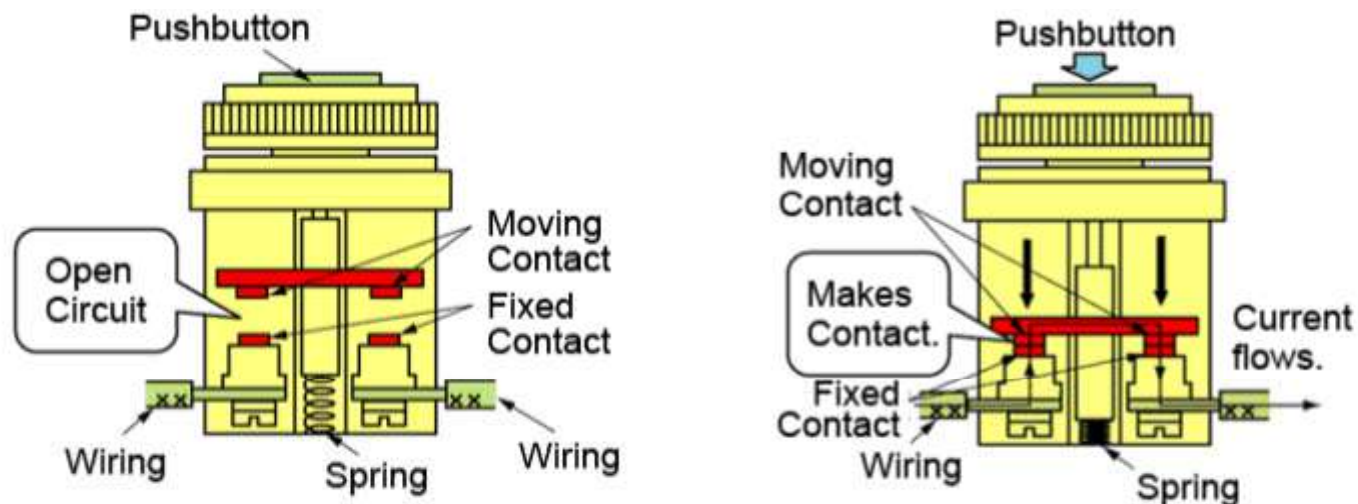

1.5

Systems that Function Using Sequence Control



(3) b Contact

Normally, a closed contact opens when provided a command.

The term "b contact" comes from the first initial of "break contact" (working contact). It is also known as a "normally closed contact".

Operation (Pushbutton Switch)

Contact is open as long as the pushbutton switch is not pressed and closed when pressed.

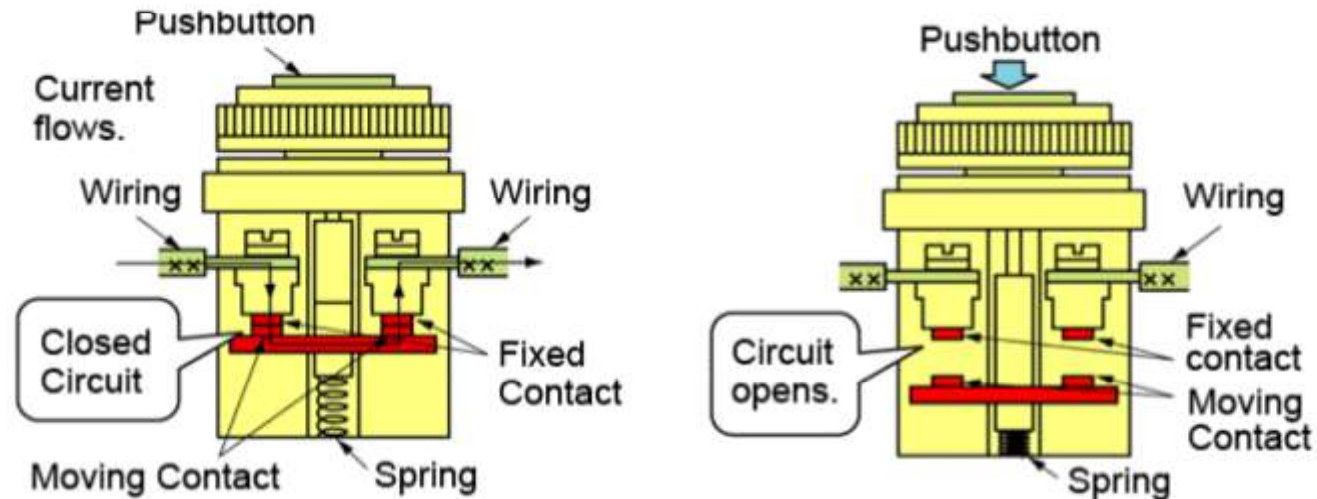

1.5

Systems that Function Using Sequence Control

**Basic Knowledge of Relays**

(Electromagnetic) relays consist of a coil and contact. The contact can be opened or closed depending on whether the coil is conducting current or not.

As was explained on the preceding page, there is both a contact output and b contact output.

Here, "a contact output" is shown in the following figure.

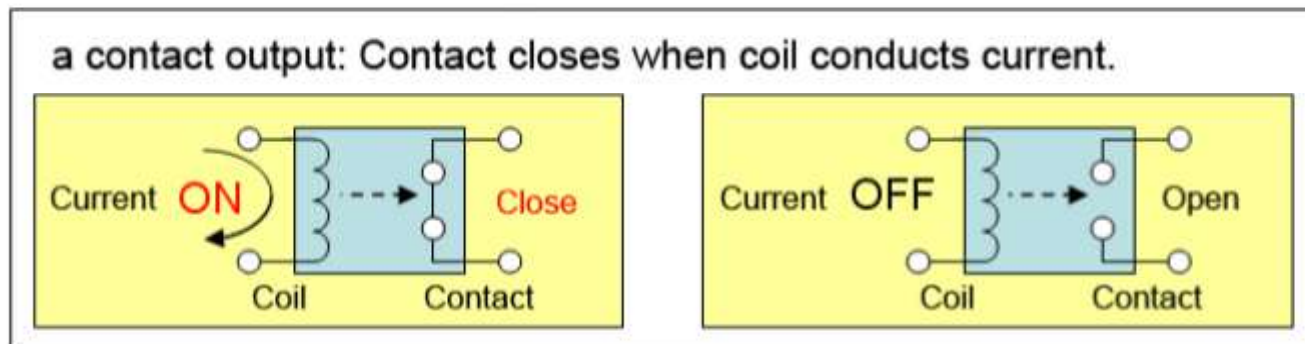

<Summary: Function of a relay>

Relays, for which current flow to the coil produces output in the form of opening or closing the contact, are equipped with the following functions.

(a) Signal insulation/amplification

Since coils and contacts are electrically insulated, input is not affected by output.

Significant output current can be controlled by insignificant coil current.

(b) Signal conversion

Using b contact output enables you to reverse the on/off relationship of input and output.

For these reasons, before the appearance of PLC, sequence control was accomplished by combinations of relays.

More convenient PLCs are widely used currently. (See Chapter 2 for details.)

Chapter 2 PLC

2.1 PLC Overview

Commonly referred to as a "Programmable Logic Controller", "PLC", "Programmable Controller" or "PC", PLC started out as a controller to satisfy the required specifications of an automobile manufacturer in the United States. (1969)

Sequence control, before the advent of the PLC, was accomplished by (contact) relay.

It had the following disadvantages.

- (a) Poor contact and wear.
- (b) Difficult to mount and wire large numbers of relays.
- (c) Difficult to modify wiring when control contents were changed.

From these backgrounds, PLCs soon came to be widely used as a programmable controller by technicians at the sites of production and installed on the production site for factory automation (FA).

<Comparison with Relay Type>



Item	Control method	
	PLC Type	Relay Type
Function	Programs enable flexible, complex control to be achieved. In addition to original sequence control, PLCs also enable a wide variety of functions such as data processing, analog positioning and communication.	Complex control using a number of relays is difficult from the standpoints of economy and reliability. They basically offer on/off control only.
Flexible Control Modification	Can be altered freely by modifying the program.	There is no alternative other than to modify wiring.
Reliability	High reliability and long life. (Basically all semiconductor)	Since relay contacts are used, they may develop poor conatacts and have a limitation of life in the case of prolonged use.
Ease of Maintenance	Equipment failure can be monitored by peripheral software, etc. PLC modules can be replaced individually.	It is difficult to determine the cause and replace when there is relay failure.
Support for Large Scale and Complexity	Offers more flexibility and extendibility than the relay type.	Use in a large scale becomes impractical in terms of time and labor.

2.2

Input Relay Operation

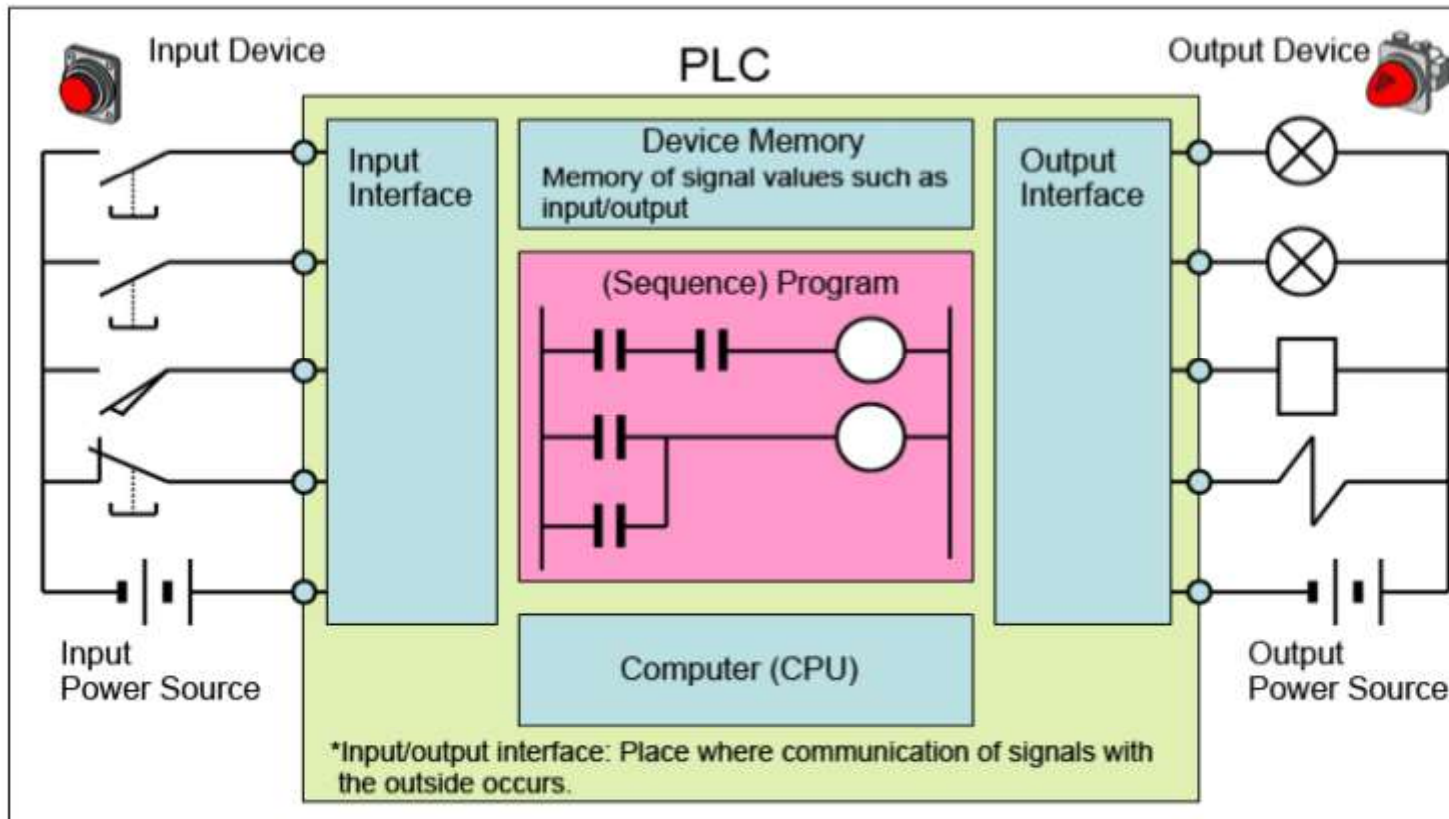

As was described on the preceding page, the basic role of the PLC is to provide sequence control by means of a program. Generally speaking, it is a dedicated controller (type of computer) that controls output equipment by program according to command signals of input equipment.

The program is based on the actions of the input and output relays. The basic operation is described here in sequence.

2.2 Input Relay Operation

Input relay operation: Import of input operation

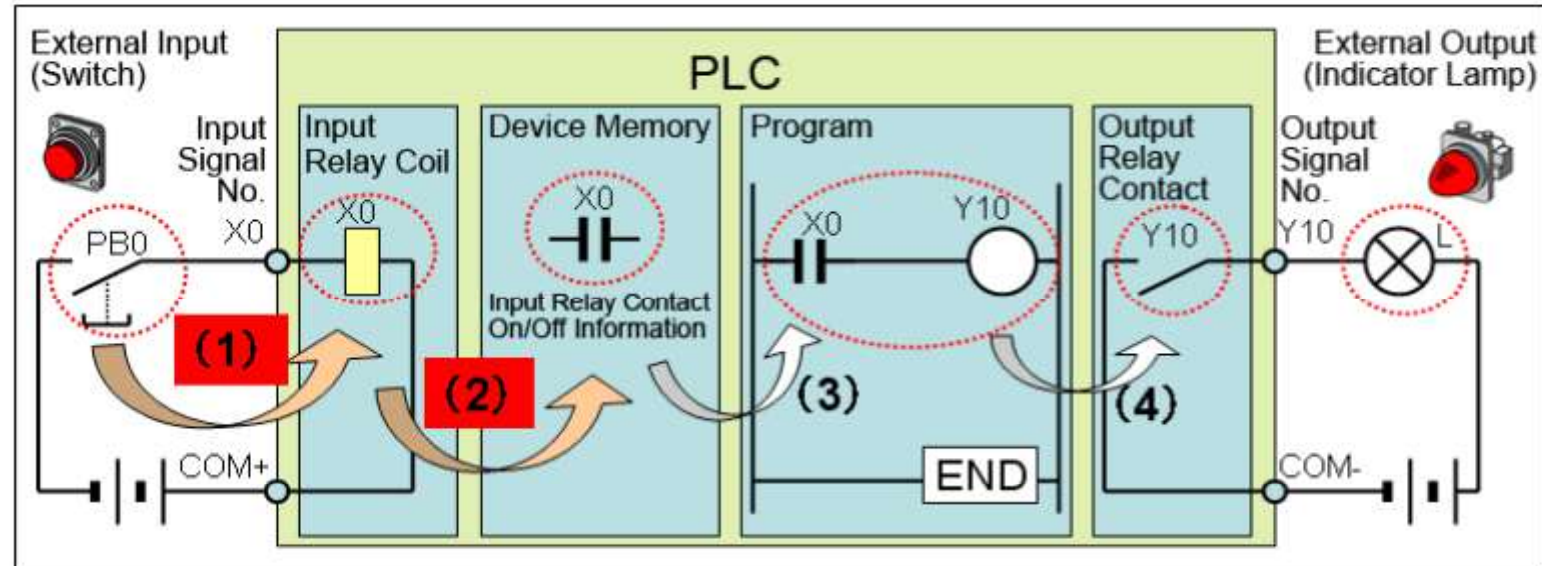

External input can be thought of as accomplished by pushbutton switch (PB0) and external output by indicator lamp (L). Signal flow is from left to right.

- (1) When external input switch PB0 (contact) connected to PLC input pin X0 shown on the left side of the figure above closes, current flows to the coil of input relay X0.
The input relay coil changes according to the status of external input equipment, and does not exist in the program.
- (2) When current flows to the coil of input relay X0, information is imported as relay X0 contact "on" information to the PLC internal device memory area and is saved.
In other words, "on/off" of input relay contact X0 used by the program corresponds to that of input pin X0 of the same number.

2.2 Input Relay Operation

Output relay operation: Program execution, external output

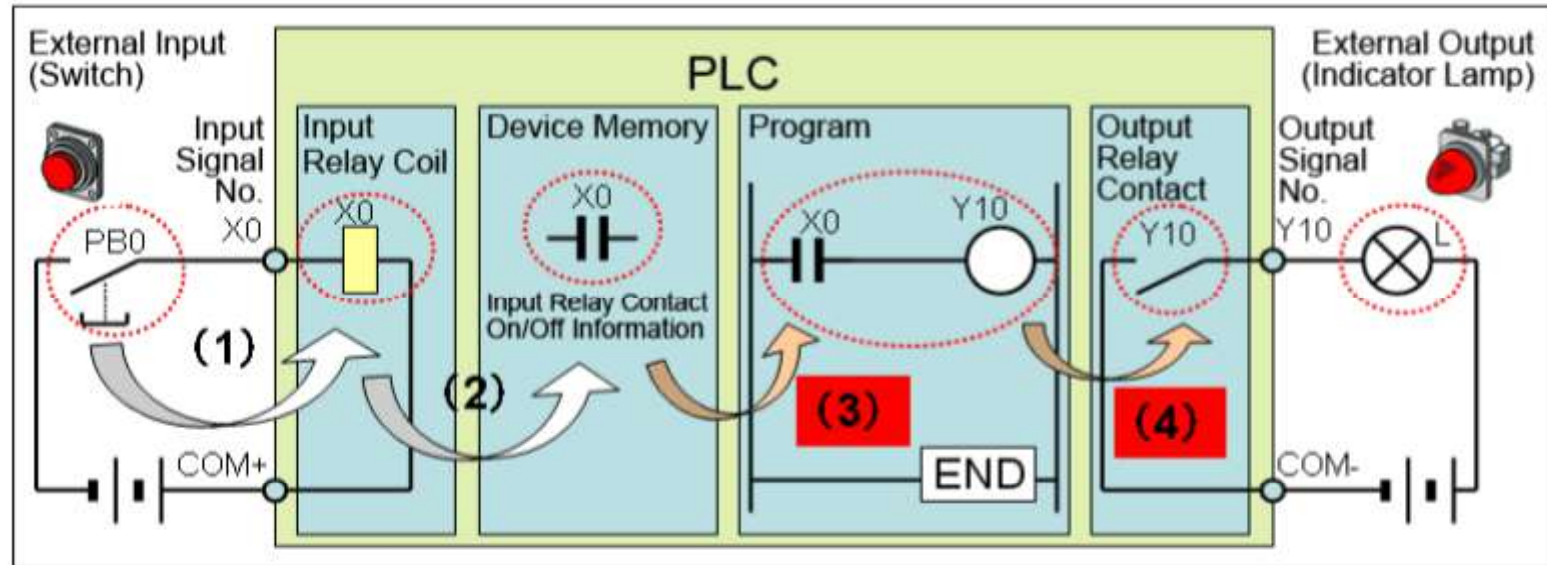

(3) In this program example, the information of input relay contact X0 in the device memory area is "on", so the output relay Y10 coil is also "on".

(4) Output signal No. Y10 corresponds to the "on" status of output relay coil Y10 of the same number; the indicator lamp of the external output equipment is therefore also "on" (lit).

<Point>

- You can think of current flowing to the (imaginary) **coil of the input relay** when the **input signal** of the PLC is "on".
- You can think of **the (imaginary) output relay being "on"** when the **output signal** of the PLC is "on".
- The terms "coil" and "contact" are used metaphorically in relation to the electrical component relay inside the PLC.

2.3

PLC Program



Ladder diagrams, which are easier for people to intuitively understand than a program of command language, are often used in conventional PLC program development.

Example 1: A program which needs both input switches X1 and X2 to be "on" for output lamp Y10 to be "on" would be as follows.

<Expression by Ladder Diagram>



"The condition of input switches X1 and X2 both being 'on'" is called an "AND" condition. In this case, symbols X1 and X2 lined up in series is the equivalent of an "AND" condition.

<Expressions by Command Language (List)>

Step No.	Command Language	Device No.
0	LD	X1
1	AND	X2
2	OUT	Y10
3	END	

The PLC CPU executes commands in sequence beginning from step No. 0. When the "END" command is reached, computation continues by returning to the initial step 0. This is referred to as "cyclic computation". The time required to run one cycle is called "scan time". Scan time is usually anywhere from several milliseconds to 20 milliseconds.

2.3

PLC Program



Example 2: A program which needs either input switches X3 or X4 to be "on" for output lamp Y20 to be "on" would be as follows.

<Expression by Ladder Diagram>

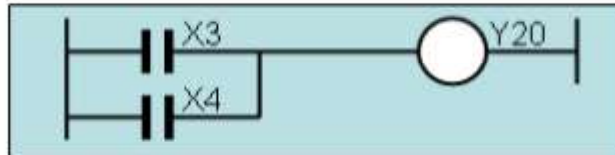

"The condition of input switch X3 or X4 being 'on'" is called an "OR" condition. In this case, symbols X3 and X4 lined up in parallel is the equivalent of an "OR" condition.

<Expressions by Command Language (List)>

Step No.	Command Language	Device No.
0	LD	X3
1	AND	X4
2	OUT	Y20
3	END	

In this case, it is an OR command instead of the AND command of example 1. Portions such as this are usually put together in a single program.

<Expression by Ladder Diagram>

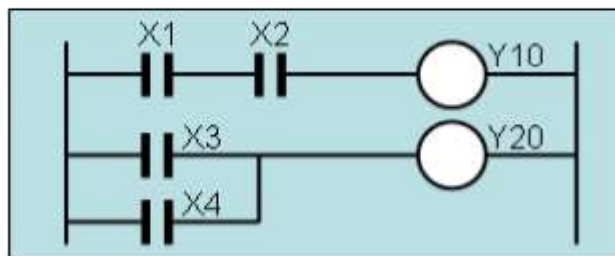

*) Because early PLCs were only equipped with a relay sequence replacement function, they could only handle on/off status. Today's PLCs can handle numerical data and have become extremely high-function devices for connecting computers to networks, etc.

2.3

PLC Program



Meaning of b Contact in Program

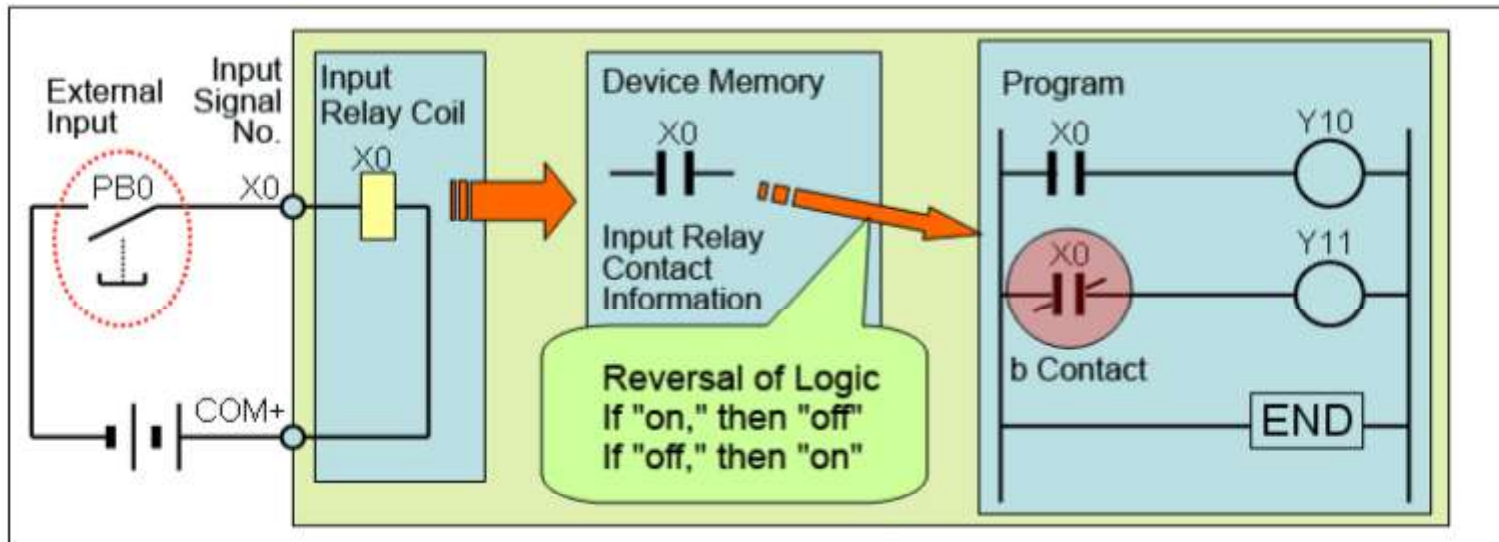

The "b contact" of input X0 in the ladder program signifies logic that is the opposite of that of signal X0 (on/off) from the input pin.

2.3

PLC Program



Timers and counters are used to provide time limit control and counting control for PLCs. Each has an independent coil and contact for each device number.

• **Timer (Notation Tx: "x" stands for a number)**

Timer function for PLC generally employ "on-delay timers" whereby the coil contact is "on" when the coil of the timer conducts electricity in excess of a preset amount of time. If the coil goes "off" even for an instance, the timer count is reset to zero and the timer contact also goes "off". The timer setting value sets how many multiples to wait, usually in 0.1-second increments. The notation "T10 K30" in the following figure means the time setting of timer No. T10 is 3 seconds.

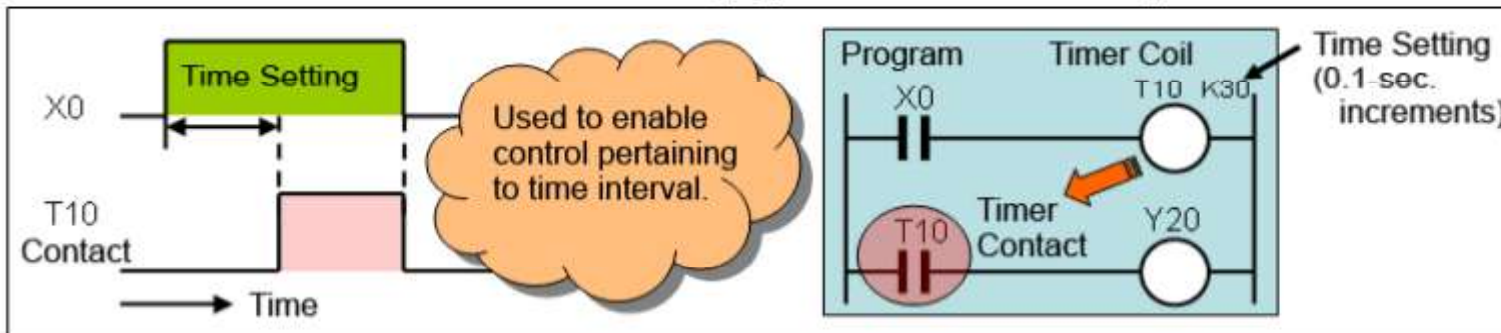

• **Counter (Notation Cx: "x" stands for a number)**

The counter function of PLC counts the times that count input changes from "off" to "on". The counter contact turns "on" when the count reaches the setting value (count up). After counting up, the count remains unchanged and the output contact remains "on" as well. When the counter register is reset, the counter count becomes zero and the counter contact is "off" as well.

In the following figure, the notation "C20 K5" means the count setting for counter No. C20 is "5".

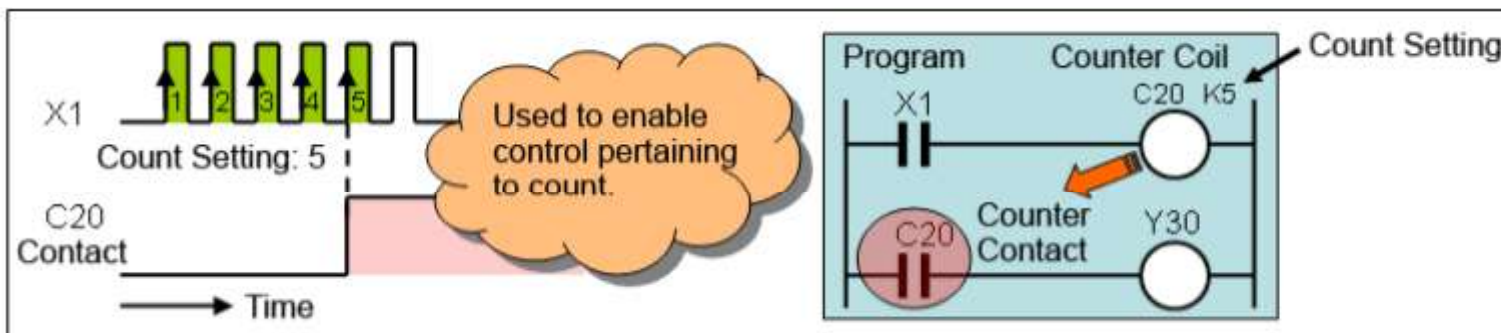

2.3

PLC Program



Let's summarize the memory device for storing PLC internal data.

<Point>

Device (Device Symbol)	Contents
X	This device is a channel of receiving signals from the external input switch, etc., of the PLC. The device symbol is "X." It is also referred to as an "input relay."
Y	This device is a channel of communicating signals outside the PLC. The device symbol is "Y." It is also referred to as an "output relay."
T	This device is a timer contained inside the PLC. It is equipped with a function for measuring time, and is equipped with coils and contacts corresponding to each timer device No. When the set time is reached, the contact can turn "on."
C	This device is a counter contained inside the PLC. It is equipped with a function for counting, and is equipped with coils and contacts corresponding to each counter device No. When the set count is reached, the contact can turn "on."

<Supplement>

(1) The example given above is a fundamental case. Actually, many more devices are available.

Example: Internal relay (Notation Mx: "x" stands for a number that indicates sequence)

Internal relays are auxiliary relays equipped with coils and contacts that can be used in the program without restriction.

The fact that the switch was pressed will be saved in the memory and will be used as a flag indicating some sort of signal or status.

(2) The type and amount of devices that can be used depends on the type of PLC.

2.3

PLC Program



Self-holding circuits are circuits that maintain the status when a self-holding relay coil is "on".

Self-holding circuits include initiation and cancellation conditions. Here we are primarily concerned with initiation conditions.

(a) As shown in the following figure, when initiation conditions ($X0 = ON$) are satisfied, the holding relay coil is "on".

(b) Consequently, because coil contact ($Y10$) of Fig. 2 is "on", coil output continues even if initiation condition $X0$ is "off".

Thus, coil output "on" status is maintained by the signal of the holding coil itself.

Because Figs. 1 and 2 show a "b contact", cancellation conditions are satisfied when $X1 = ON$, and the holding coil becomes "off" immediately.

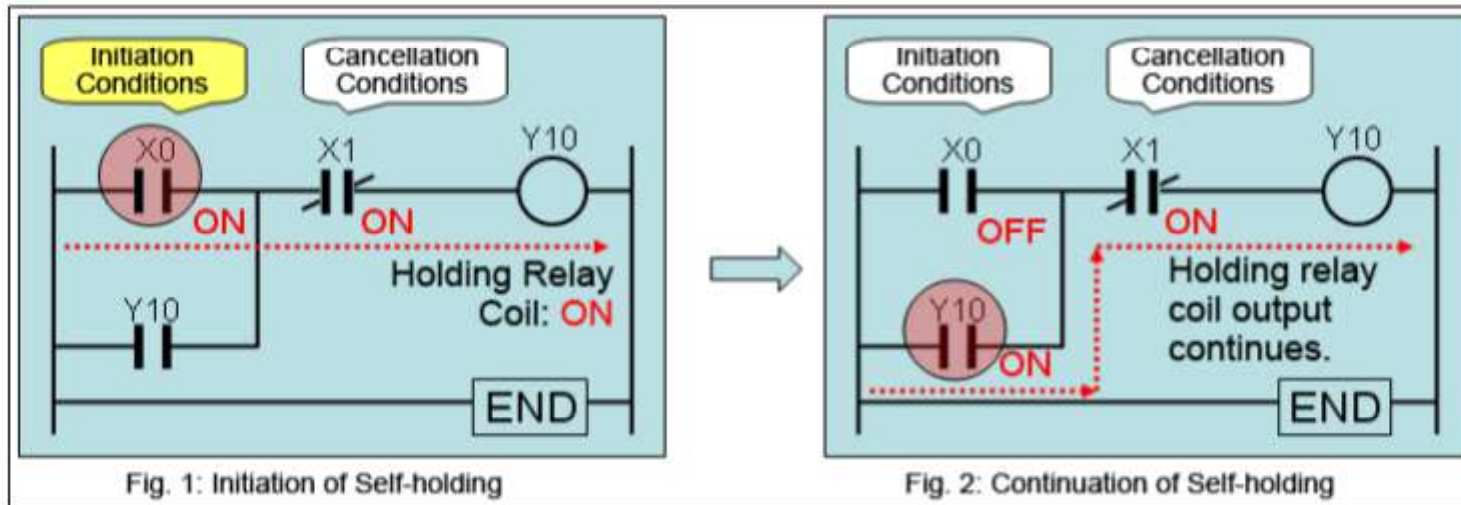

Using the SET and RST commands of the PLC, you can produce a function similar to that of a self-holding circuit in the form shown in Fig. 3.

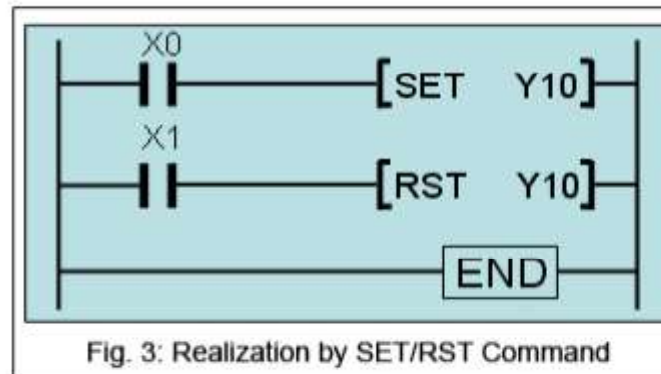

2.4

PLC Features



So far we have covered sequence control and PLCs. Since Mitsubishi Electric entered PLC market in 1977, our PLCs(MELSEC) have been used in various fields such as FA for many years, and being trusted by customers all over the world. Finally, we would like you to know the reason why PLCs have continued to be used for a wide range of applications.

- **Real time reaction**
 - Able to respond to instructions instantly
- **High reliability and long-term stability**
 - Because they use components with high reliability, they can function for an extended period of time with minimal incidents of failure.
Backup battery ensures that important data is not lost even in the event of power failure.
- **Language suitable for control field**
 - Language system is easy to understand for those with an understanding of electrical control.
- **Expandability**
 - Facilitates structural expansion.
 - Able to respond flexibly to specifications by modification of the program.
 - Offers numerical computation in addition to sequence control.
Able to receive information from a computer to enable comprehensive automation such as production management.
- **Environment resistance**
 - Continue to work in harsh environments
- **Mutual connectivity**
 - Offers an assortment of products to match the specifications of input/output devices connected.
- **Compatibility**
 - The language system of the program never changes significantly, so you can use it without worry.
 - Offers long product life with minimal impact of model change.
- **Enhanced support system**
 - Offers complete backup system such as internet, e-learning and school.



Factories are not the only places that require the features of such PLCs. In the future, PLCs will be needed for a wide range of applications including construction, civil engineering, agriculture, transportation, telecommunications, public waste disposal, public facilities and leisure facilities.

Now that you have completed all of the lessons of the FA Equipment for Beginners (PLCs) Course, you are ready to take the final test. If you are unclear on any of the topics covered, please take this opportunity to review those topics.

There are a total of 10 questions (28 items) in this Final Test.

You can take the final test as many times as you like.

How to score the test

After selecting the answer, make sure to click the **Score** button. Failure to do so will not score the test. (Regarded as unanswered questions.)

Score results

The number of correct answers, the number of questions, the percentage of correct answers, and the pass/fail result will appear on the score page.

Correct answers : 3

Total questions : 10

Percentage : 30%

To pass the test, 60% of correct answers is required.

Proceed

Review

Retry

- Click the **Proceed** button to exit the test.
- Click the **Review** button to review the test. (Correct answer check)
- Click the **Retry** button to retry the test multiple times.

Test Final Test 1

Sequence Control

Fill in the blanks in the following configuration diagram of sequence control with the appropriate terms.

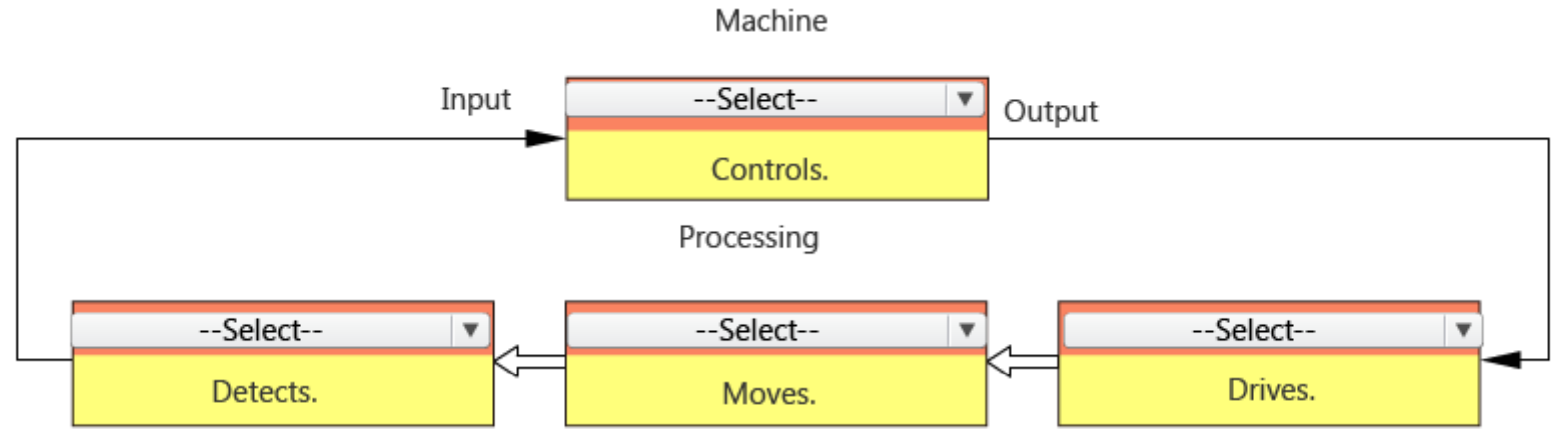

[Score](#) [Back](#)

Type of Sequence Control

Select the corresponding type of control from the following text describing control.

Control that operates equipment according to an established sequence.

Control that operates equipment when predetermined conditions are met by combining status and completion signals of the control target.

Control that operates equipment by established time and timing.

Control that operates equipment by counting until a predetermined count is reached.

Function of a relay

Select the correct items from text that explains the function of relays.

- Device whereby the contact opens/closes according to whether control current to the coil is on or off.
- Device whereby the contact opens/closes according to whether a pushbutton switch is on or off.
- Device whereby a buzzer sounds when control current to the coil is on.

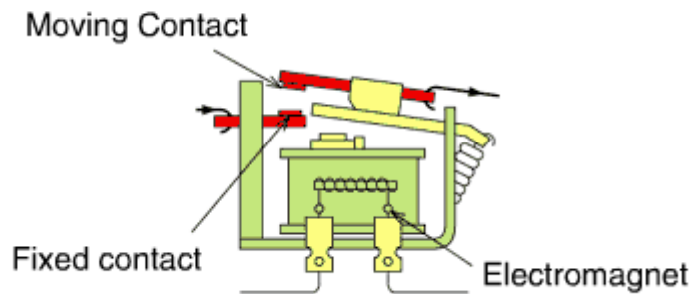
[Score](#)[Back](#)

Function of contacts

Fill in the blanks in the following text indicating the function of contacts.

A normally open contact of a relay switch closes when provided a command is called a/an contact.

In reverse, a contact that is normally closed and opens when provided a command is called a/an contact.

Sequence circuit

Select the condition for which the coil of the following sequence circuit becomes "on."

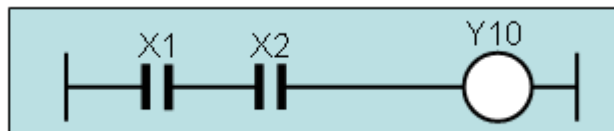

Coil Y10 becomes "on" when both contacts X1 and X2 are "on."

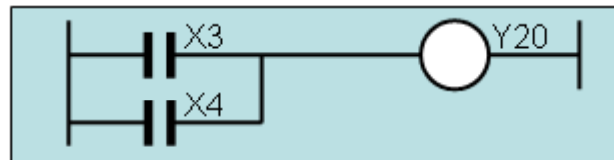

Coil Y20 becomes "on" when either contacts X3 or X4 is "on."

Sequence Program Operation

Fill in the blanks of the following explanation of a sequence program.

The PLC CPU executes commands in sequence beginning from step No.

When the command is reached, computation continues by returning to the initial step number.

This is referred to as " computation."

The time required for one cycle is referred to as " time."

PLC function

Fill in the blanks in the following explanation of a PLC.

A PLC is a that executes sequence control by controlling output equipment according to signals of input equipment, etc..

Control of which output signal to operate or stop operating by input signal is executed by a program according to .

Sequence device symbol

Select the corresponding device symbol from the following text describing sequence control.

- A means of receiving signals from external input switch, etc., of the PLC, it is referred to as an "input relay."
- A means of communicating output signals outside the PLC, it is referred to as an "output relay."
- Auxiliary relay inside the PLC used for creating a program.
- Timer inside the PLC equipped with a function for measuring time.
- Counter inside the PLC equipped with a function for counting.

Advantages of Using a PLC

Select the correct description of the features of PLC usage.

- Basically used for on/off control only.
- Control contents can be altered freely by modifying the program.
- Life is restricted by poor contact of the relay.

Score

Back

Advantages of Using a PLC

Select the correct description of the features of PLC usage.

- a contact
- b contact
- Cannot be distinguished from the ladder program.

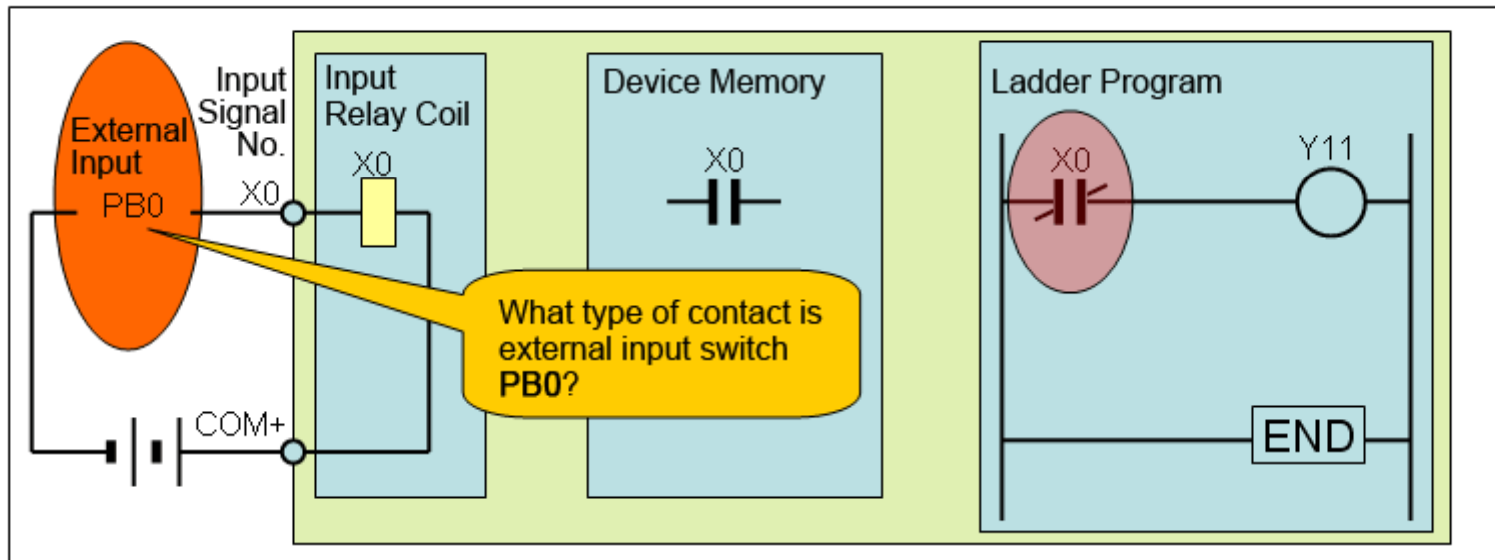

Score

Back

Test**Test Score**

You have completed the Final Test. Your results are as follows.
To end the Final Test, proceed to the next page.

Correct answers : 0

Total questions : 10

Percentage : 0%

[Proceed](#)[Review](#)[Retry](#)

You failed the test.

You have completed the **FA Equipment for Beginners (PLCs)** Course.

Thank you for taking this course.

We hope you enjoyed the lessons and the information you acquired in this course is useful for configuring systems in the future.

You can review the course as many times as you want.

Review

Close