

PLC

MELSEC-Q Series Basics

This course is for participants who are using the MELSEC-Q series programmable controller for the first time.

Introduction Purpose of the Course

This course provides basic knowledge of setting up the hardware, from system design to checking the wiring. The course is intended for those using the MELSEC-Q series programmable controller (PLC) for the first time or the person in charge of the hardware system.

[Forward](#)

The contents of this course are as follows.
We recommend that you start from Chapter 1.

Chapter 1 - MELSEC-Q Series

You will learn about the features of the MELSEC-Q series and component names.

Chapter 2 - PLC System Construction Procedure

You will learn about the system construction procedures using an example system.

Chapter 3 - System Design

You will learn how to define control items and how to examine the connection with external equipment, necessary I/O specifications and number of I/O points.

Chapter 4 - Product Selection

You will learn how to select module types.

Chapter 5 - Advance Preparation

You will learn about advance preparation from confirming individual modules to formatting the memory.

Chapter 6 - Installation and Wiring





You will learn how to install and wire each module.

Chapter 7 - Wiring Check

You will learn how to check I/O signal wirings using the GX Works2 software.

Final Test

Passing grade: 60% or higher.

Go to the next page		Go to the next page.
Back to the previous page		Back to the previous page.
Move to the desired page		"Table of Contents" will be displayed, enabling you to navigate to the desired page.
Exit the learning		Exit the learning. Window such as "Contents" screen and the learning will be closed.

Safety precautions

When you learn by using actual products, please carefully read the safety precautions in the corresponding manuals.

Precautions in this course

- The displayed screens of the software version that you use may differ from those in this course.

This course is for the following software version:

- GX Works2 Version 1.91V

Chapter 1 MELSEC-Q Series

In this course, you will learn how to set up the Mitsubishi MELSEC-Q series general-purpose PLC system hardware.

1.1 What is a PLC?

What is a programmable controller or PLC (Programmable Logic Controller)?

A PLC is a rugged digital computer that performs sequence control and logic operations. Typically they are used to control electrical signals sent to output devices based on the electrical signals it receives from input devices.

Programmable controllers require a program, which can be created using dedicated software on a personal computer. The programs can be easily modified to allow the PLC to perform different functions for different tasks.

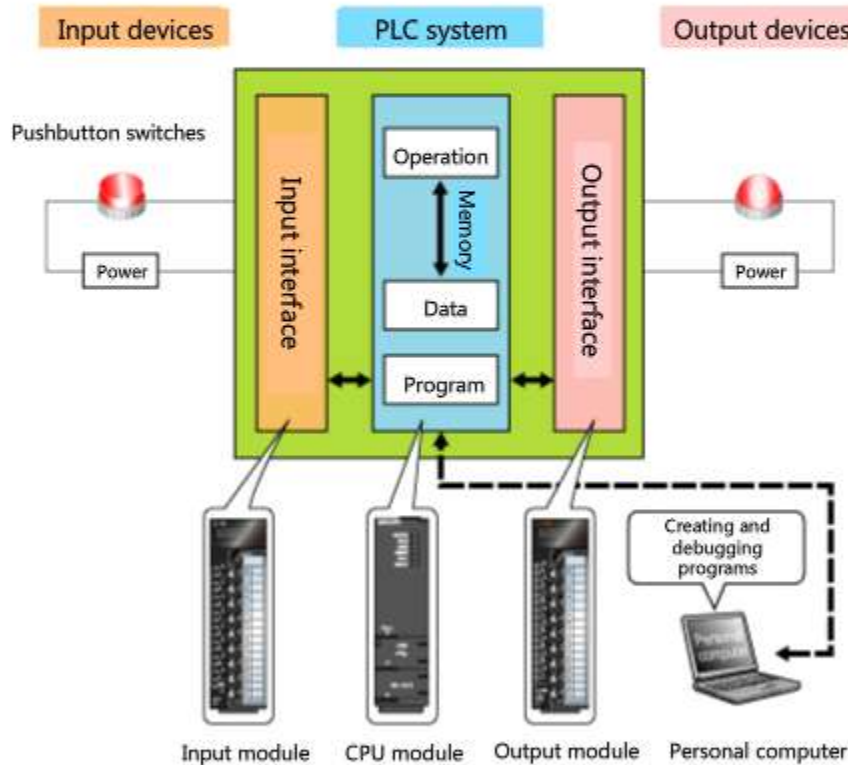







Module name	Use
Input module	Receives electrical signals from external devices and converts them into data to be used by the CPU.
CPU module	Operates the sequence program and performs signal input/output processing.
Output module	Transmits electrical signals to external devices when commanded by the CPU.

1.2

Comparison between MELSEC-Q Series and MELSEC-L Series

Some basic differences between MELSEC-Q Series and MELSEC-L Series programmable controllers can be seen in the table below

	MELSEC-Q series	MELSEC-L series
Method of adding modules	<p>Modules are individually installed on the base unit, allowing for easy replacement and certain modules to be hot-swapped.</p>  <p>Modules are installed on the base unit</p>	<p>Modules can be connected horizontally. As no base unit is required, the installation area is minimized.</p>  <p>Modules are directly connected</p>
Implementation of load distribution (*1) and function distribution (*2)	<p>In order to achieve load and function distribution, different CPU types and sequence can be connected using the high-speed bus provided by the base unit.</p>  <p>Load distribution by up to four CPUs</p>	<p>Functions are divided for each PLC CPU and information is shared through the network.</p>  <p>Function distribution through the network</p>
Available functions	<p>A variety of Q series special function modules are available. Special function modules can be added according to the specifications of connected devices to support various applications.</p>  <p>Many types of special function modules are available</p>	<p>The MELSEC-L series having the CPU module equipped with minimum I/O, network, and positioning, provides many functions in a small footprint, which is ideal for small scale applications.</p>  <p>Built-in functions: Input/output, CC-Link, Ethernet (*3), and data logging</p>

*1 Load distribution: A method of using multiple CPU modules to share processing in case a heavy load is concentrated on one CPU module.

*2 Function distribution: A method used for minimizing the area affected by a fault. It involves dividing the processing into units of functions such as the production line, packing line, sequence, and positioning.

*3 Ethernet is a registered trademark of Xerox Corp.

The same **GX Works2** software for development and maintenance is used for both the Q and L series controllers.

1.3

MELSEC-Q Series Features

Supporting the system extension with extension base units

A total of seven extension base units can be used together.

With these extension base units, a small-scale to a large-scale system can be configured flexibly in accordance with the application.

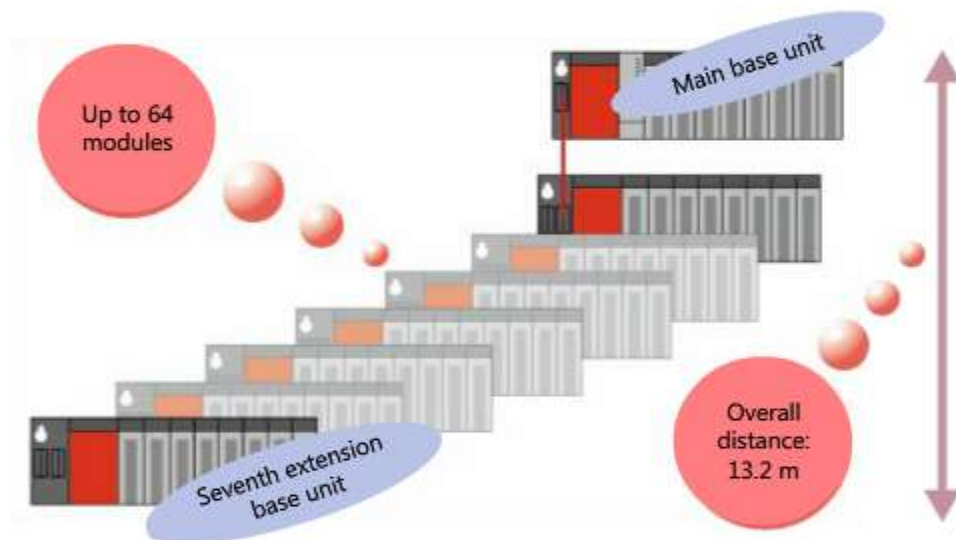

1.3

MELSEC-Q Series Features

Multiple CPU system

Up to four high performance CPU modules are connectable.

Each CPU module takes on a task distributed based on the control type, operation type, process, or machine equipment.

Decentralizing tasks to multiple CPU modules will result in high speed, high performance, and highly scalable operation for the whole system.

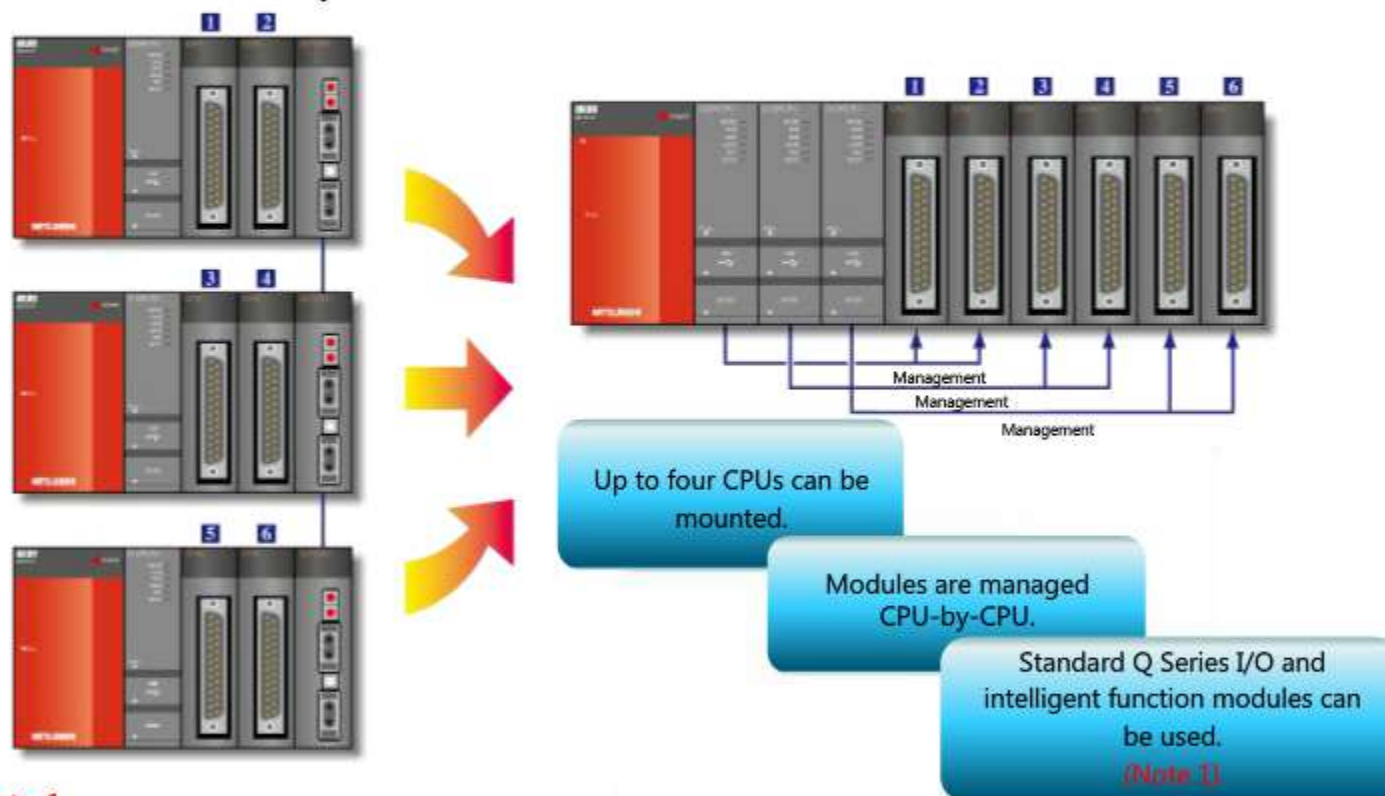

Note 1

The number of connectable intelligent function modules and connectable versions are limited. Refer to the Q series user's manuals for details.

1.4

Module Names and Functions

In this chapter, you will learn about the overview of each module and their component names.

Below is the MELSEC-Q series lineup.

A base unit, a power supply module, and a CPU module are always required. Use additional modules depending on the application.

Place the mouse cursor on a module to see its description.

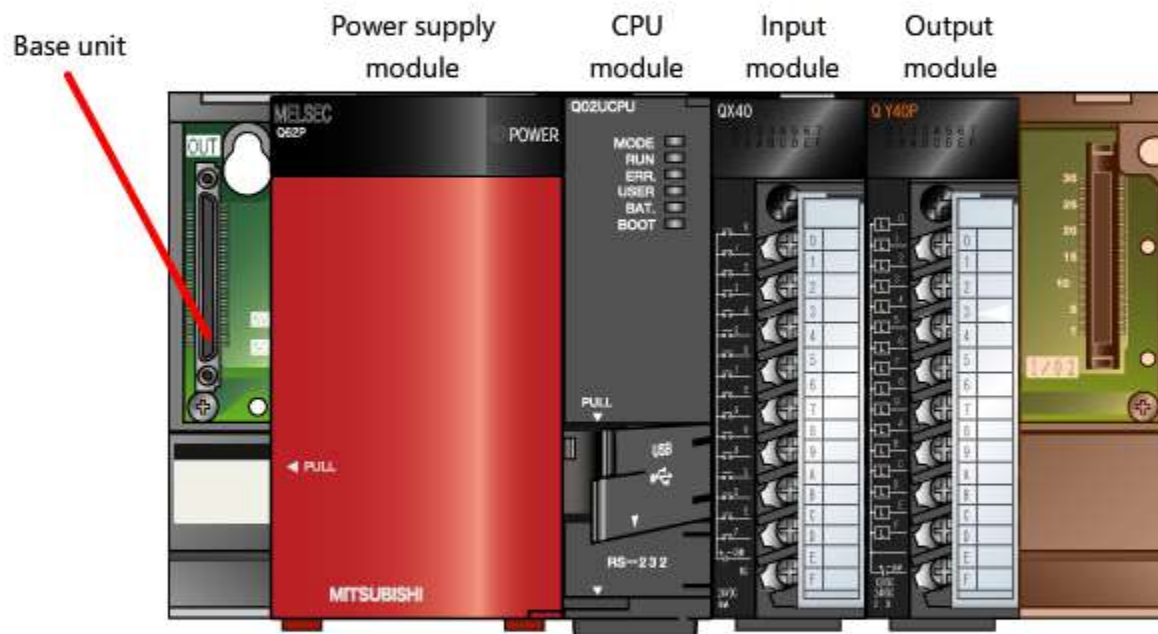

Base unit

Consists of slots where modules are fixed onto. Those slots convey 5VDC power from the power supply module to other modules.

1.4.1 CPU module component names

Let's learn the names and applications of individual component of the CPU module. If you place the mouse cursor in the following table or on a specific component of the CPU module drawings, the relevant areas are highlighted.

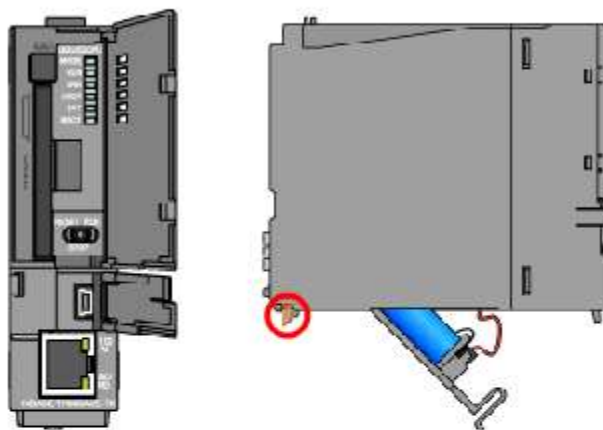

Name	Description
LED part	Indicates the operating status or error status of the CPU module.
RUN/STOP/RESET switch	Used to control the operating status of the CPU module.
USB connector	Used to connect USB peripheral devices.
Ethernet connector	Connects to peripheral devices by Ethernet.
Module fixing hook	Fixes a module onto the base unit.
Battery	Provides backup power for backing up data in the standard RAM and latch devices in case of a power failure.
Battery connector pin	Used for connecting a lead wire for the battery. (The lead wire is disconnected from the connector at the factory to protect the battery during shipping.)
Module mounting lever	Supports mounting of a module onto the base unit.

1.4.2 Power supply module component names

Let's learn the names and applications of individual component of the power supply module. If you place the mouse cursor in the following table or on a specific component of the power supply module drawings, the relevant areas are highlighted.



Name	Description
POWER LED	Indicates the operating status of the power.
ERR. Terminal	Turns on when the entire system is operating normally. Turns off when a stop error occurs in the CPU module.
FG terminal	A ground terminal connected to the shielded pattern on the printed circuit board
LG terminal	A ground terminal for the power filter. For AC input, it has half the potential of the input voltage.
Power input terminal	Power input terminal
+24V, 24G terminals	Provides 24 VDC output across these terminals.
Terminal cover	Protective cover of the terminal block.

1.4.3 I/O module component names

Let's learn the names and applications of individual component of the I/O module.

If you place the mouse cursor in the following table or on a specific component of the I/O module drawings, the relevant areas are highlighted.

Screw terminal
block type

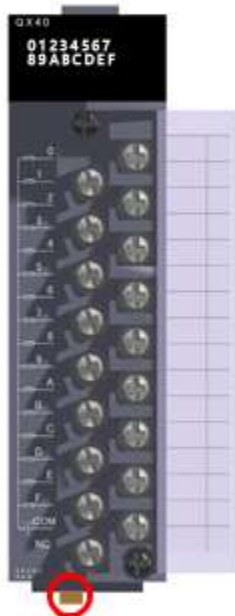

40-pin connector
type



Name	Description
I/O operation status indicator LEDs	Indicates the ON/OFF status of I/O operations.
Connector for external device	Used to connect an I/O signal cable from external equipment.
Terminal block	Used to connect I/O signal cables to/from external equipment.
Terminal cover	Protects against electric shock when turning on the power.
Module fixing hook	Fixes a module onto the base unit.
Module mounting lever	Supports mounting of a module onto the base unit.

1.4.4 Base unit component names

This section explains about component names of the base unit and their uses. If you place the mouse cursor in the following table or on a specific component of the base unit drawings, the relevant areas are highlighted.

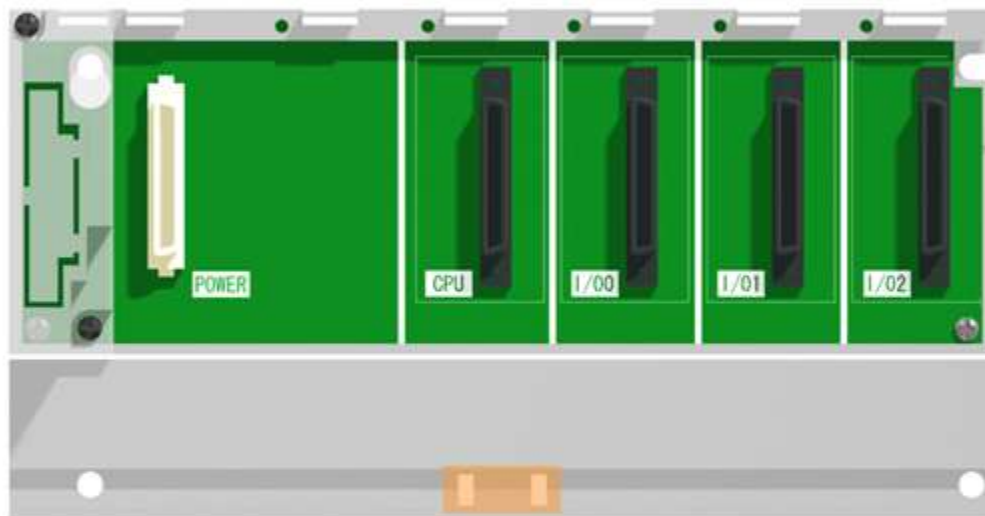

Name	Description
Extension cable connector	Connector for sending/receiving signals to/from an extension base unit. Used to connect an extension cable.
Module connector	Used to connect the power supply, CPU, I/O, and intelligent function modules.
Base mounting hole	Used to mount the base unit on a control panel. Screw size: M4
DIN rail adapter mounting hole	Used to mount a DIN rail adapter.

1.5

Sequence Program Development and Maintenance

The PLC engineering software **GX Works2** is used for developing and maintaining MELSEC series PLC programs. The same GX Works2 software is used for **both the MELSEC-Q and MELSEC-L series**.

By connecting a personal computer in which GX Works2 is installed to the CPU module through a USB or LAN cable, you can develop programs, verify operations, write to the CPU module, confirm the module status, and collect error history information.

In this course, you will learn how to initialize the CPU module (Section 5.6) and how to confirm that the I/O wiring is correct by monitoring the connections from GX Works2.

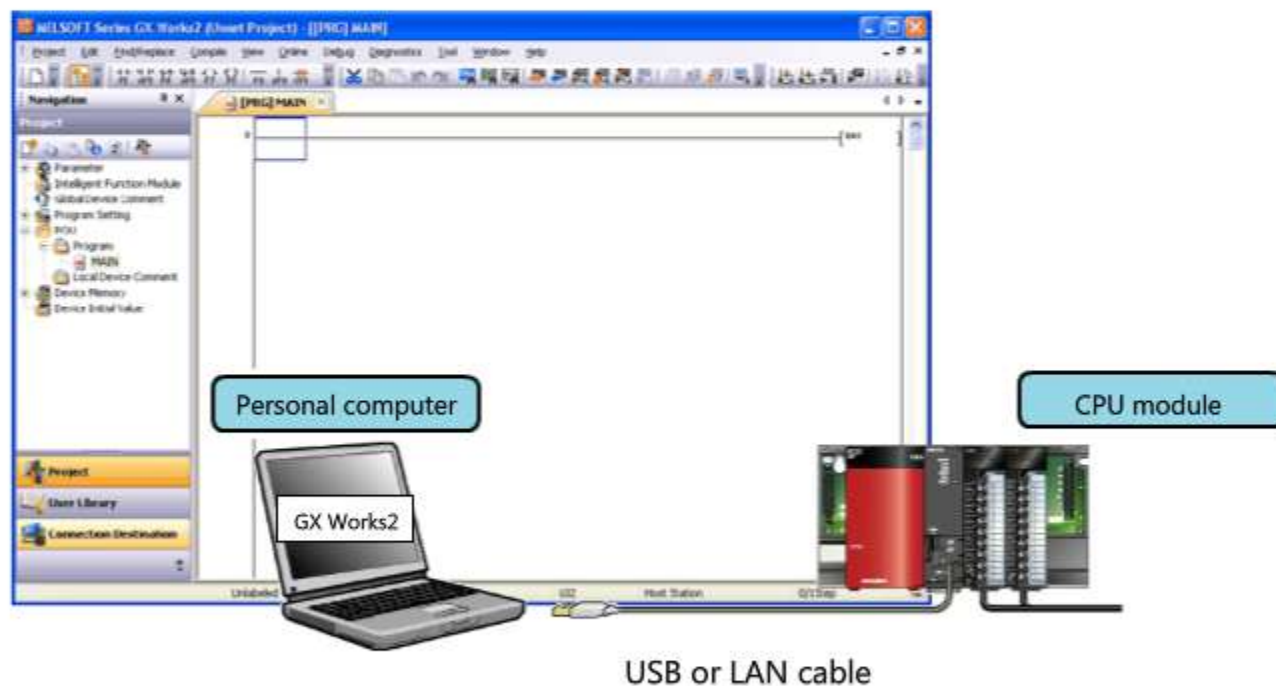

Chapter 2 PLC System Construction Procedure

This chapter describes the procedures for constructing a programmable controller (PLC) system. In this course, you will learn the hardware design procedure as part of the system construction procedure.

Hardware design

(1) System Design Chapter 3



(2) Product Selection Chapter 4



(3) Advance Preparation Chapter 5



(4) Installation and Wiring Chapter 6



(5) Wiring Check Chapter 7



Software design

(6) Program Design GX Works2/GX Developer Basics Course



(7) Programming GX Works2/GX Developer Basics Course



(8) Debugging GX Works2/GX Developer Basics Course



(9) Operation

**Scope of
this course**

2.1 Hardware Configuration of Example System

In this course, you will construct a PLC system (called "example system" hereafter), which starts the robot according to a procedure. A diagram of the hardware configuration of the example system is shown below with a list of hardware components.

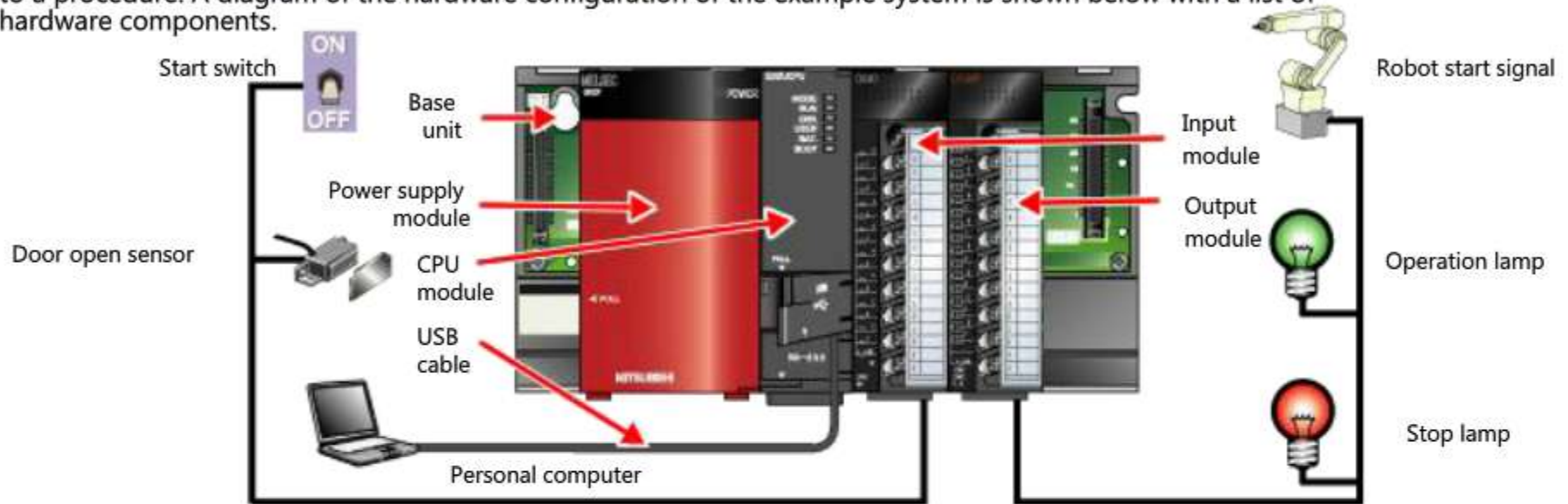

Item	Component	Model	Description
PLC system	Base unit	Q33B	Consists of slots where modules are fixed onto. Power and data are conveyed through this base unit.
	Power supply module	Q62P	Supplies power to modules including the CPU module and I/O module.
	CPU module	Q02UCPU	Controls the PLC system.
	Input module	QX40	Takes in the ON/OFF statuses of the switch.
	Output module	QY40P	Outputs ON/OFF signals to the lamps.
	USB cable	MR-J3USBCBL3M	Connects the personal computer, in which GX Works2 is installed, to the CPU module.
External I/O equipment	Switch	-	Set to ON to start control.
	Sensor	-	Detects whether the door is open or closed.
	Robot	-	Operates in accordance with control signals.
	Two lamps	-	Light according to the operation status.

Chapter 3 System Design

In this chapter, you will learn how to determine control items and examine the necessary I/O specifications and number of I/O points.

System Design Chapter 3



Product Selection Chapter 4



Advance Preparation Chapter 5



Installation and Wiring Chapter 6



Wiring Check Chapter 7

Learning steps in Chapter 3

- 3.1 Defining Control Items
- 3.2 Examining the Necessary I/O Specifications and Number of I/O Points

3.1

Defining Control Items

One of the first steps to designing a system is to identify what needs to be controlled. In this example system, the starting and stopping of a robot is controlled.

When the door to the safety fence is open the robot is prevented from starting, and when the door is opened during operation, it is stopped.

Example system operation

Robot control panel



Robot in the safety fence



When you set the **start switch** to OFF, the **robot start signal** turns off to stop robot operation.

Simultaneously, the **operation lamp** on the control panel turns off, and the **stop lamp** turns on.

[Previous](#)

3.2 Examining the Necessary I/O Specifications and Number of I/O Points

Next, consider the necessary I/O specifications and number of I/O points.

According to the control items in Section 3.1, select the I/O specifications and number of I/O points as shown below.

Name	Input specification	Output specification
Start switch	24 VDC ON/OFF input: 1 point	-
Door open sensor	24 VDC ON/OFF output: 1 point	-
Robot start signal	-	24 VDC transistor output: 1 point
Operation lamp	-	24 VDC transistor output: 1 point
Stop lamp	-	24 VDC transistor output: 1 point

Number of input points: 2

Number of output points: 3

Chapter 4 Product Selection

In Chapter 4, you will learn how to select products (I/O modules, CPU module, power supply module, and base unit).

System Design Chapter 3



Product Selection Chapter 4



Advance Preparation Chapter 5



Installation and Wiring Chapter 6



Wiring Check Chapter 7

Learning steps in Chapter 4

- 4.1 Selecting the Types and Number of the I/O Modules
- 4.2 Selecting a CPU Module Suitable for Control Requirements
- 4.3 Selecting a Power Supply Module for Operating All Selected Modules

4.1

Selecting the Types and Number of the I/O Modules

In factories, 24 VDC is commonly used as a power supply for sensors and valves.

The I/O specifications you confirmed in Section 3.2 are as follows:

- (1) Input: 24 VDC ON/OFF input: 2 points
- (2) Output: 24 VDC transistor output: 3 points

To satisfy the following specs., select **QX40** for the input module, and **QY40P** for the output module.

Module model	Input specification		Output specification	
	Rated input voltage	Number of input points	Rated load voltage	Number of output points
QX40	24 VDC	16 points	-	-
QY40P	-	-	12 to 24 VDC	16 points

If the actual system requires I/O points more than 16 points, use a 32-point I/O module or a higher spec. module.

4.2 Selecting a CPU Module Suitable for Control Requirements

The Q-Series CPU specifications are listed in the table below. Choose which CPU is appropriate for the application based on the number of required I/O points, program capacity, and processing speed.

Q01UCPU is enough for the specs. specified in Chapter 3 (five I/O points and 1K or less step program capacity). However, if you require any more specs., for example to record opening/closing history of the door used in the sample, etc., you may need a memory card.

Now, let's select **Q02UCPU**, which supports a memory card.

	Number of I/O points
Number of input points	2 points
Number of output points	3 points
Total	5 points

Program capacity
1K steps or less

Memory card
Use

Q-Series CPU Specifications

The **Q02UCPU** specifications are shown in light grey.

Module model	Number of I/O points	Memory card	Program capacity
Q01UCPU	1024 points	Unavailable	15K steps
Q02UCPU	2048 points	Available	20K steps
Q03UDCPU	4096 points	Available	30K steps

4.3 Selecting a Power Supply Module for Operating All Selected Modules

The specifications of power supply modules are listed in the table below.
To select a power supply module, check whether the following two conditions are satisfied.

- (1) Specifications of the power supply for a PLC system

100 to 240 VAC

or

24 VDC

In the example system, commercial 100 VAC power is used. Therefore, the Q61P is chosen.

- (2) The power consumption of all modules must not exceed the rated output current.
To calculate the system's maximum power consumption, add the power consumption of CPU module, I/O modules, and the base unit.

CPU module (Q02UCPU)
Power consumption
0.23 A

+

I/O module
Power consumption
QX40: 0.05A,
QY40P: 0.065A

=

Power consumption of all modules 0.345 A \leq Rated output current (5 VDC)

When selecting a power supply module, consider the power consumption of the module itself plus the power consumption of the CPU module.

Q-Series power supply specifications

The **Q62P** specifications are shown in light grey.

Module model	Input power	Rated output current (5 VDC)	Rated output current (24 VDC)
Q61P	100 to 240 VAC	6 A	-
Q62P	100 to 240 VAC	3 A	0.6 A
Q63P	24 VDC	6 A	-

Q62P has a 24VDC output port and can be used to drive internal circuits of the I/O module. In that case, the I/O module does not require external power supply, **but do not use this Q62P to drive the load.**

Chapter 5 Advance Preparation

In Chapter 5, you will learn the advance preparation to be made before installation and wiring. The advance preparation includes confirming individual modules, mounting the modules, wiring the power supply module, verifying that power can be turned on normally, and initializing the CPU module.

System Design Chapter 3



Product Selection Chapter 4



Advance Preparation Chapter 5



Installation and Wiring Chapter 6



Wiring Check Chapter 7

Learning steps in Chapter 5

- 5.1 Procedure for Advance Preparation
- 5.2 Confirming Individual Modules
- 5.3 Assembling Modules
 - 5.3.1 Connecting the battery
 - 5.3.2 Assembling Modules
 - 5.3.3 Assigning I/O Numbers
- 5.4 Wiring the Power Supply Module
- 5.5 Checking the Power Supply
- 5.6 Initializing the CPU Module
 - 5.6.1 Connecting the CPU Module to the Personal Computer
 - 5.6.2 Setting Up the Connection between GX Works2 and PLC System
 - 5.6.3 Formatting Memory

5.1 Procedure for Advance Preparation

Perform advance preparation before installation and wiring as follows.

(1) Confirming Individual Modules (Section 5.2)

Visually check the modules you purchased for any damage.



(2) Assembling Modules (Section 5.3)



(3) Wiring the Power Supply Module (Section 5.4)



(4) Checking the Power Supply (Section 5.5)



(5) Initializing the CPU Module (Section 5.6) Format the memory in the CPU Module using GX Works2.

Unpack the product package and check for missing components by referring to "PACKING LIST" in the manual that came with the product. Next, visually check each component for any damage.

PACKING LIST

The following items are included in the package of this product. Before use, check that all the items are included.

(1) CPU module

(a) Q00JCPU or Q00UJCPU

Product Name	Quantity
Module	1
Battery (Q6BAT)	1
Base unit mounting screw (M4 × 14 screw)	4
Safety Guidelines (IB-0800423)	1

(b) Other than Q00JCPU and Q00UJCPU

Product Name	Quantity
Module	1
Battery (Q6BAT)	1

(2) Main base unit

Product Name	Quantity
Unit	1
Base unit mounting screw (M4 × 14 screw ^{*1})	4/5 ^{*2}
Safety Guidelines (IB-0800423)	1

*1 For the slim type main base unit, M4 × 12 screws are supplied.

*2 Screws as many as the number of mounting holes are supplied.

(3) Extension base unit

Product Name	Quantity
Unit	1
Base unit mounting screw (M4 × 14 screw)	4/5 ^{*3}

*3 Screws as many as the number of mounting holes are supplied.

(4) Power supply module or I/O module

Product Name	Quantity
Module	1

5.3**Assembling Modules**

Assemble the modules according to the following procedure.

(1) Connecting the Battery (Section 5.3.1)



(2) Assembling Modules (Section 5.3.2)

5.3.1 Connecting the battery

The battery is used to back up clock data, error history, etc. stored in memory in the CPU module. The purchased product is delivered with the power connector of the battery disconnected from the CPU module; be sure to connect it, otherwise the data in memory will be lost when the PLC power is turned off. In some cases, even the main program could be lost depending on the type of CPU module.

Connect the battery according to the following procedure. (To make it easier, connect the battery before mounting the CPU module.)

(1) Open the cover at the bottom of the CPU module.



(2) Confirm the directions of the connectors, and insert the battery side connector into the CPU module side connector.



(3) Close the cover at the bottom of the CPU module.



Complete



5.3.2 Assembling modules

Mount each module to the base unit in the following procedure.

(1) Hook the module's projection into the module fixing hole of the base unit.



(2) Press in the module until it clicks into the base unit.



(3) Make sure that the module is fixed into the base unit securely.



Complete



5.3.3 Assigning I/O numbers

You will learn how to assign I/O numbers required for the CPU module to send data to, or receive data from, an I/O module.

The following I/O numbers are initially assigned for the system configuration of Chapter 2.1.

Assigned to	Input number	Output number
QX40	X00 to X0F	-
QY40P	-	Y10 to Y1F

The table below shows the I/O correspondence for the example system.

Creating a correspondence table reduces program errors (device number input errors) and improves programming efficiency.

I/O device name	Device No.	I/O type	Description
Start switch	X0	Input	This switch starts or stops robot operation.
Door open sensor	X1	Input	This sensor checks whether the door of the safety fence of the robot is open. When the door opens, the sensor turns on. When the door closes, the sensor turns off.
Robot start signal	Y10	Output	When this signal turns on, the robot starts operation.
Operation lamp	Y1E	Output	This lamp lights while the robot is operating.
Stop lamp	Y1F	Output	This lamp lights while the robot is stopped.

5.3.3 Assigning I/O numbers

The example system to which a device number has been added is shown below.

Example system operation

Robot control panel



Robot in the safety fence



When you set the **start switch (X0)** to OFF, the **robot start signal (Y10)** turns off to stop robot operation. Simultaneously, the **operation lamp (Y1E)** on the control panel turns off, and the **stop lamp (Y1F)** turns on.

Replay



Previous

5.4 Wiring the Power Supply Module

Connect the power and ground lines as seen in the following diagram.
Grounding is necessary to prevent electrical shocks, malfunctions, and noise interference.

(1) Connect the 100 VAC power supply to the power input terminal via the circuit breaker and isolation transformer.

(2) Ground the LG and FG terminals.

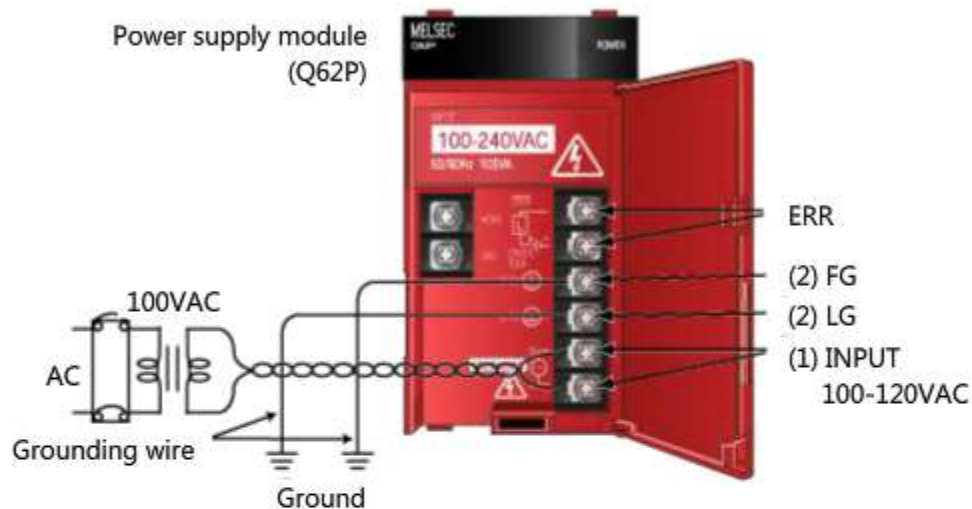

5.5 Checking the Power Supply

Use the following procedure to determine if the system is operating normally when powered on.

- (1) Before turning on the power, double check the following:
 - The power supply is wired correctly
 - The supply voltage matches the power supply input voltage



- (2) Set the CPU module to STOP.
Open the front cover of the CPU module and set the switch to STOP



- (3) Power on the system
Close the circuit breaker allowing the supply power to enter the power supply module.



- (3) Check that the power supply is working normally.

- 1) The green POWER LED on the power supply module is illuminated.
- 2) The red ERR. LED on the CPU module is flashing.
(When the CPU module is powered on but parameters have not yet been written, the ERR. LED will flash but this is not a problem at this time.)



RESET/STOP/RUN

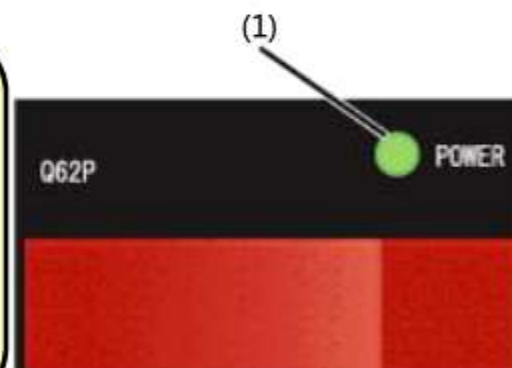

5.6 Initializing the CPU Module

Sequence programs and parameters are written to the memory in the CPU module. The memory is not ready to use when it is purchased; you need to **format** (initialize) the memory so it can be used.

You can format memory using the PLC engineering software **GX Works2**. For this operation, the CPU module must be connected to a personal computer via a USB cable. Before formatting, install GX Works2 in a personal computer and have a USB cable ready.

Format the memory according to the following procedure.

(1) Connecting the CPU Module to the Personal Computer (Section 5.6.1)



(2) Setting Up the Connection between GX Works2 and Programmable Controller (Section 5.6.2)



(3) Formatting Memory (Section 5.6.3)

5.6.1**Connecting the CPU module to the personal computer**

Connect the USB cable between the CPU module and the USB port of the personal computer.

Personal computer



CPU module



USB cable



5.6.2

Setting up the connection between GX Works2 and PLC system

After connecting the CPU module to the personal computer, set up the connection between GX Works2 and the PLC system. Note that communication cannot be performed by only connecting the devices with the USB cable.

Use [Transfer setup] to set up the connection.

On the next page, try performing the transfer setup using the simulated window.

An example of the Transfer Setup window is shown below.

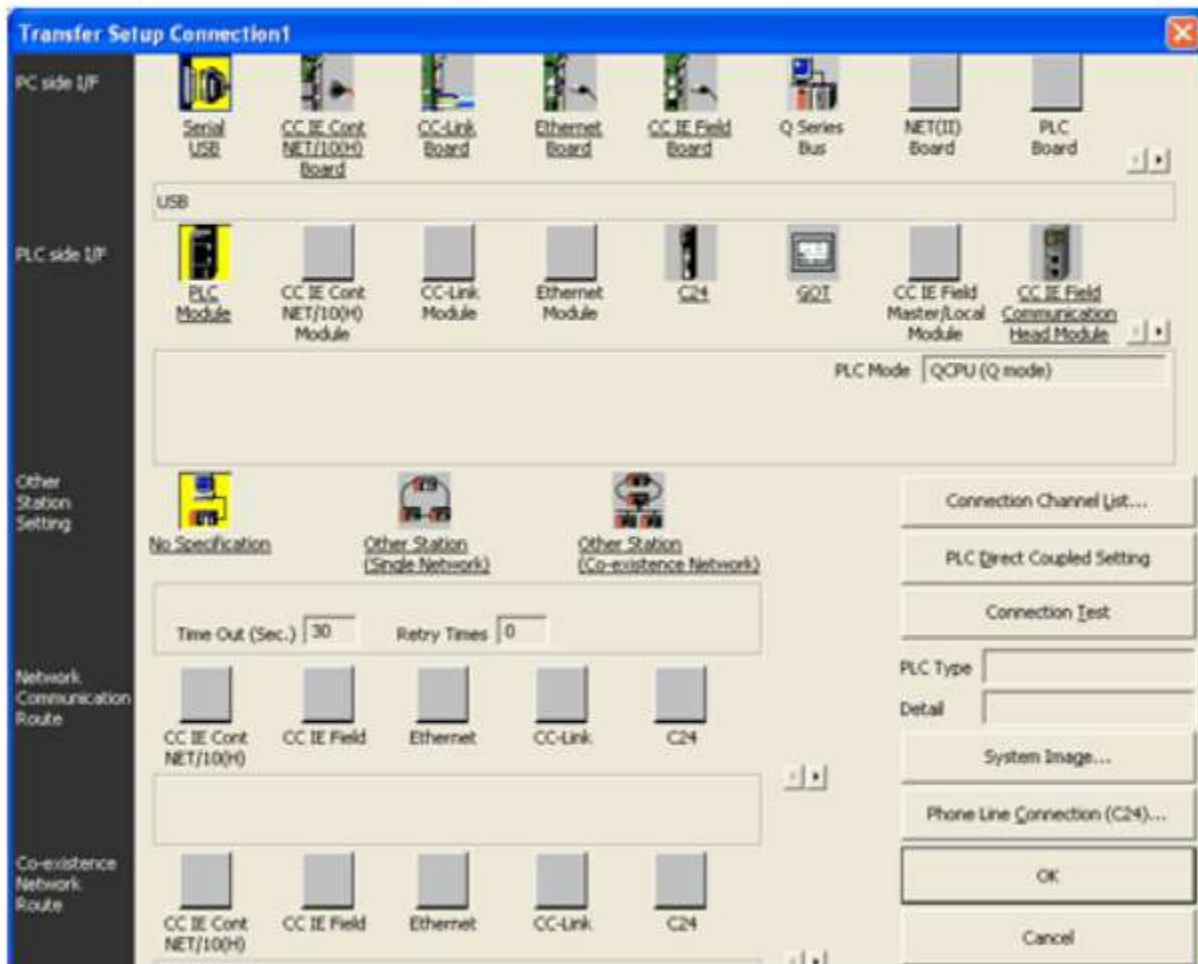

5.6.2

Setting up the connection between GX Works2 and PLC system

MELSOFT Series GX Works2 (Unset Project) - [[PRG] MAIN]

Project Edit Find/Replace Compile View Online Debug Diagnostics Tool Window Help



Navigation

Connection Destination



Current Connection

Connection1

All Connections

Connection1

Project

User Library

Connection Destination

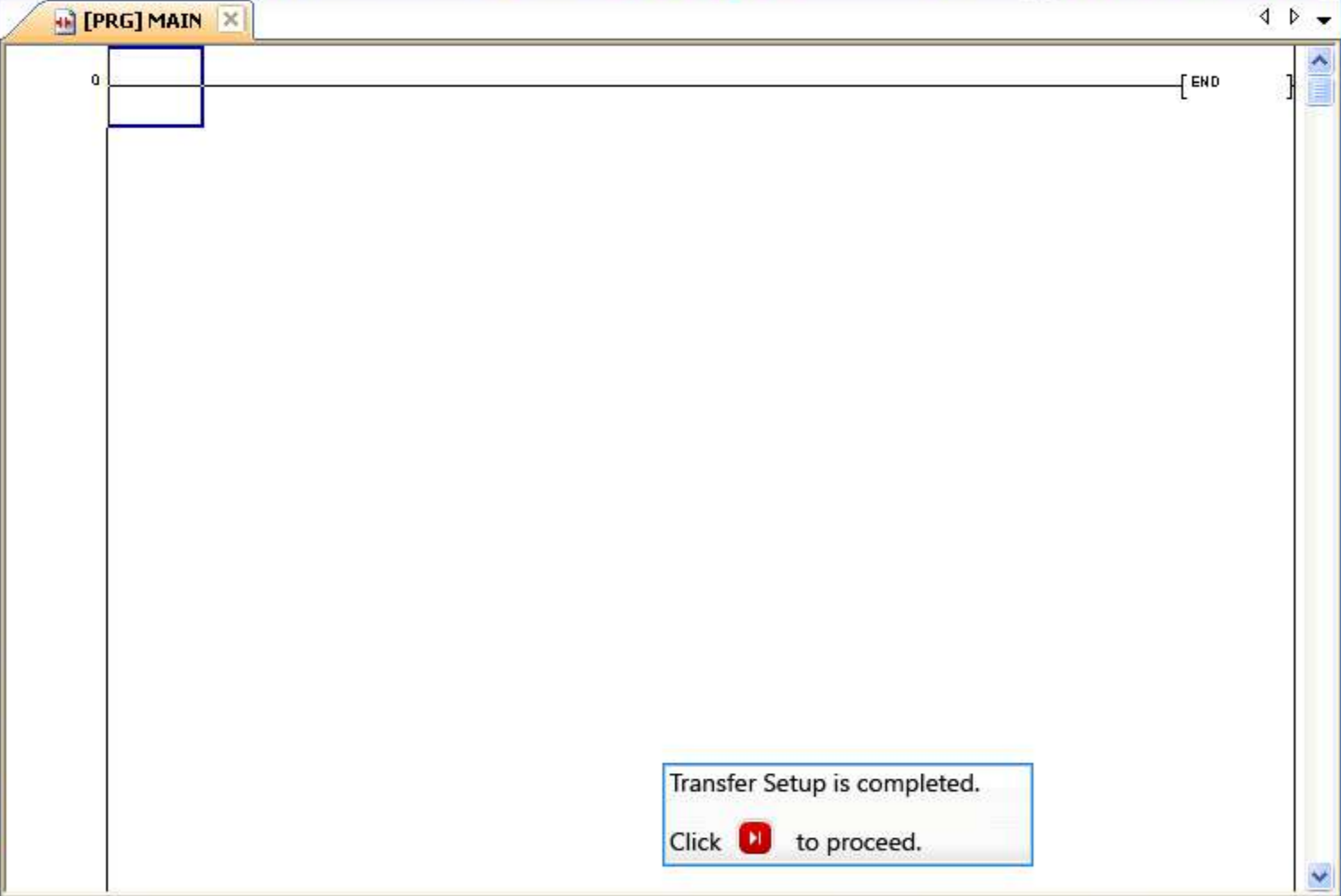

Transfer Setup is completed.
Click  to proceed.

Unlabeled

Q02U

Host Station

0/1Step

NL



5.6.3 Formatting memory

Upon completion of the transfer setup, GX Works2 is ready to communicate with the CPU module. Continue to format the memory in the CPU module using [Format PLC Memory] of GX Works2.

On the next page, try performing [Format PLC Memory] using the simulated window.

An example of the Format PLC Memory window is shown below.

Format PLC Memory

Connection Channel List

Connection Interface: USB <--> PLC Module

Target PLC: Network No. 0 Station No. Host PLC Type Q02U

Target Memory: Program Memory

Format Type

Do not create a user setting system area (the required system area only)

Create a user setting system area

High speed monitor area from other station: 0 K Steps (0--15K Steps)

Online change area of multiple blocks: [Dropdown] K Steps

Execute Close

5.6.3

Formatting memory

MELSOFT Series GX Works2 (Unset Project) - [[PRG] MAIN]

Project Edit Find/Replace Compile View Online Debug Diagnostics Tool Window Help

Navigation

Project

- Parameter
- Intelligent Function Module
- Global Device Comment
- Program Setting
- POU
 - Program
 - MAIN
 - Local Device Comment
- Device Memory
- Device Initial Value

Project

User Library

Connection Destination

[PRG] MAIN

0 [] --- [END]

The PLC memory is now formatted.
 Click  to proceed.

Chapter 6 Installation and Wiring

In Chapter 6, you will learn how to install and wire each module.

System Design Chapter 3



Product Selection Chapter 4



Advance Preparation Chapter 5



Installation and Wiring Chapter 6



Wiring Check Chapter 7

Learning steps in Chapter 6

- 6.1 Installation Environment
- 6.2 Installation Position
- 6.3 Grounding
- 6.4 Wiring I/O Modules

6.1

Installation Environment

Do not install the system in a location subject to the environmental conditions listed below. Installing and operating the system in such locations could result in electrical shock, fire, malfunction, product damage, or product deterioration.

1. Temperature and humidity

- The environmental temperature is outside the range of 0 to 55°C (32 to 131°F)
- The environmental humidity is outside the range of 5 to 95%
- Rapid temperature changes are causing condensation

2. Atmosphere

- Affected by corrosive gas or flammable gas
- A lot of dust, a conductive powder such as iron powder, oil mist, salt, or organic solvent

3. Noise

- Subject to strong radio frequency interference (RFI) or electro magnetic interference (EMI).

4. Vibration and impact

- Vibration or impact is applied directly to the product

5. Location

- The product is in direct sunlight

6.2

Installation Position

To keep the area well-ventilated and to allow for replacement of the module, secure the following distances above and below the modules and between structures and components. Depending on the system configuration used, larger distances than shown below may be needed.

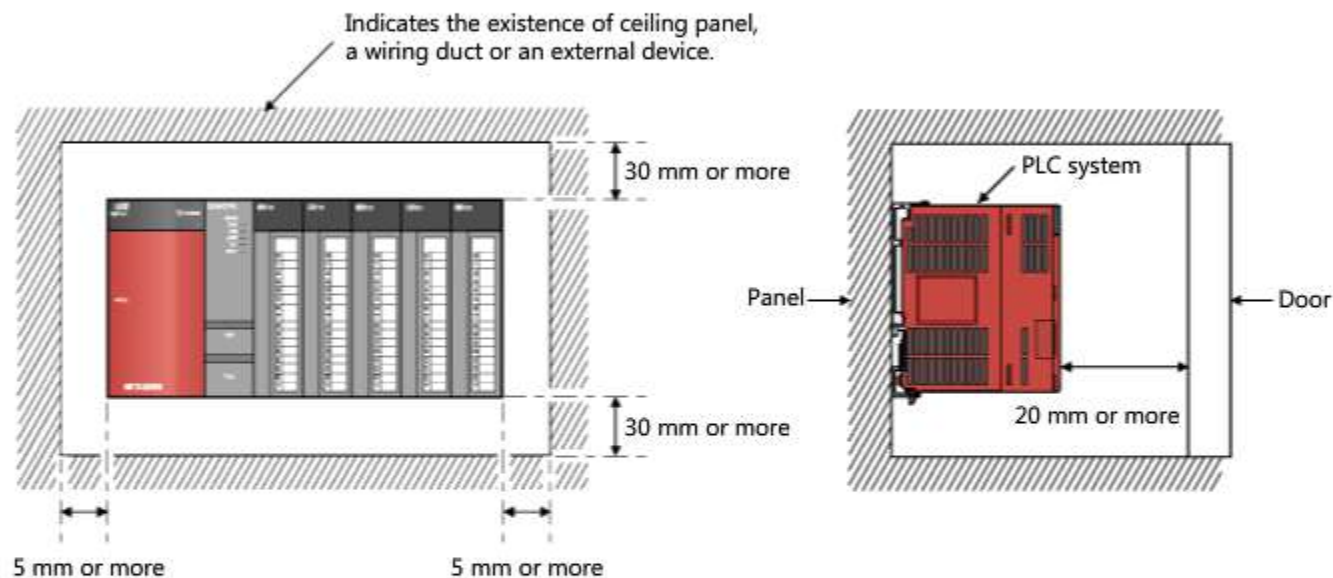

6.3

Grounding

To prevent electrical shock and malfunction, observe the following for grounding.

- Provide independent grounding wherever possible. (Grounding resistance: 100Ω or less)
- If independent grounding cannot be provided, provide shared grounding using grounding wires of the same length.
- Bring the grounding point as close to the programmable controller as possible so that the grounding wire can be shortened.

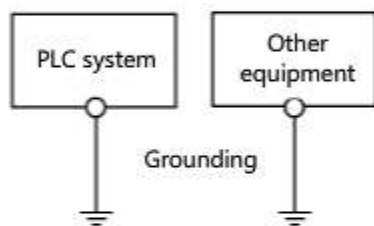

(1) Independent grounding:
Recommended

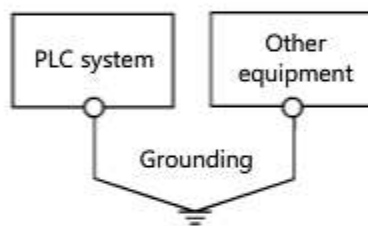

(2) Shared grounding:
Allowed

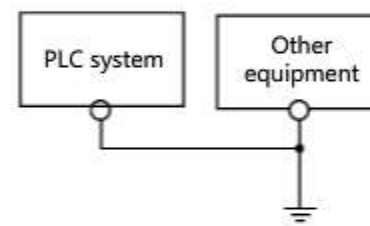

(3) Common grounding:
Not allowed



6.4 Wiring I/O Modules

Perform wiring with the input module (QX40) and output module (QY40P) as shown below. Use the diagram below to connect the start switch (X0), door open sensor (X1), robot start signal (Y10), operation lamp (Y1E), and stop lamp (Y1F).

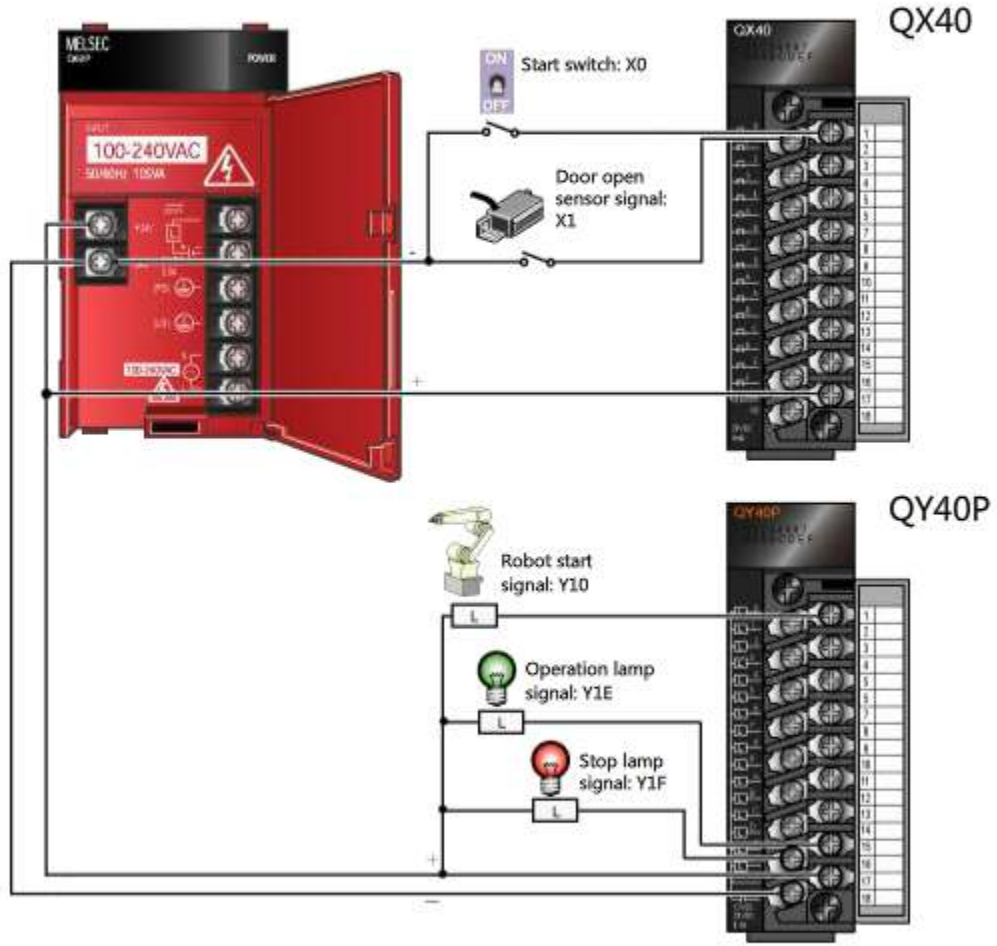

Chapter 7 Wiring Check

Before you start programming, you must check whether the wiring is done correctly. In this chapter, you will learn how to check input signals and output signals.

System Design Chapter 3



Product Selection Chapter 4



Advance Preparation Chapter 5



Installation and Wiring Chapter 6



Wiring Check Chapter 7

Learning steps in Chapter 7

- 7.1 Checking Input Signals
- 7.2 Checking Output Signals

7.1

Checking Input Signals

First, visually check the I/O wiring to ensure there is no problem.

Next, check the input signal wiring using [Device/buffer memory batch monitor] of GX Works2.

[Device/buffer memory batch monitor] enables real-time monitoring of the status (ON or OFF) of the specified range of devices.

On the next page, try the device/buffer memory batch monitor using the simulated window.

An example of the device/buffer memory batch monitor window is shown below.

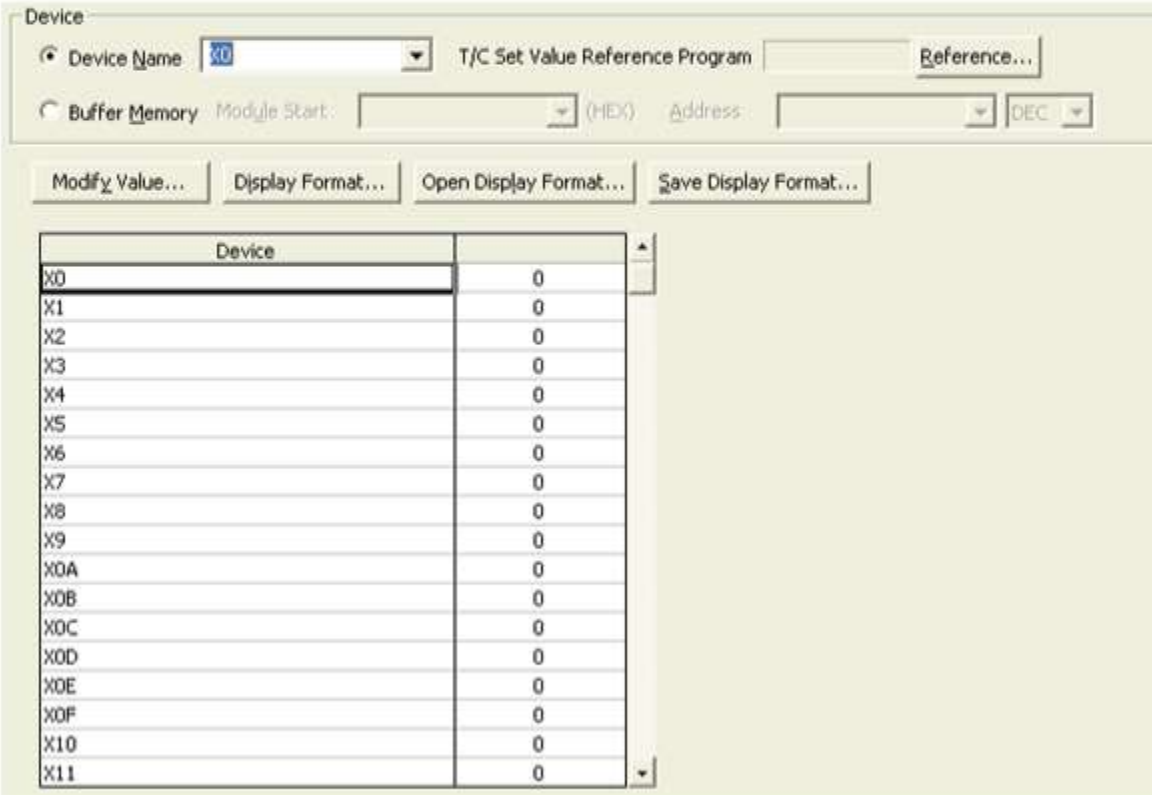

Device

Device Name T/C Set Value Reference Program

Buffer Memory Module Start: (HEX) Address: DEC

Modify Value... Display Format... Open Display Format... Save Display Format...

Device	
X0	0
X1	0
X2	0
X3	0
X4	0
X5	0
X6	0
X7	0
X8	0
X9	0
X0A	0
X0B	0
X0C	0
X0D	0
X0E	0
X0F	0
X10	0
X11	0

7.1

Checking Input Signals

MELSOFT Series GX Works2 (Unset Project) - [Device/Buffer Memory Batch Monitor-1]

Project Edit Find/Replace Compile View Online Debug Diagnostics Tool Window Help

Navigation [PRG] MAIN Device/Buffer Memory Bat...

Project

- Parameter
- Intelligent Function Module
- Global Device Comment
- Program Setting
- POU
 - Program
 - MAIN
 - Local Device Comment
- Device Memory
- Device Initial Value

Project

User Library

Connection Destination

Device

 Device Name T/C Set Value Reference Program
 Buffer Memory Module Start (HEX) Address DEC

X0 and all subsequent input devices are displayed.

Device	
X0	0
X1	0
X2	0
X3	0
X4	0
X5	0
X6	0
X7	0
X8	0
X9	0
X0A	0
X0B	0
X0C	0
X0D	0
X0E	0
X0F	0
X10	0
X11	0

View Display Format...

Preparation for checking input signals is now completed.

Click  to proceed.

Unlabeled

Q02U

Host Station

MELSEC

7.1 Checking Input Signals

After completing the preparation for the device/buffer memory batch monitor, check the input signal wiring as follows.

- Turn on the start switch (X0) and door open sensor (X1). Click the start switch and door open sensor in the figure below.
- Using [Device/buffer memory batch monitor], confirm that the devices corresponding to the start switch (X0) and door open sensor (X1) turn on (1 is displayed in the window).

The diagram illustrates the connection between an input device and a PLC system. The input device includes a start switch (X0) and a door open sensor (X1). The PLC system is shown with its terminal block. The start switch is currently OFF, and the door open sensor is OFF (door closed).

The screenshot shows the 'Device' window in the software. The 'Device Name' is set to X0. The 'Buffer Memory' is set to 'Module Start'. The window displays a table of input devices and their current status.

Device	Status
X0	0
X1	0
X2	0
X3	0
X4	0
X5	0
X6	0
X7	0
X8	0
X9	0
X0A	0
X0B	0
X0C	0
X0D	0
X0E	0
X0F	0
X10	0

Callouts indicate the status of the inputs:

- The start switch is OFF (0).
- The door open sensor is OFF (0).

7.2

Checking Output Signals

Next, using **Forced input output registration/cancellation**, check the output signal wiring.

[Forced input output registration/cancellation] allows you to forcibly change the status (ON or OFF) of each device from GX Works2. On the next page, try the forced input output registration/cancellation using the simulated window. An example of the forced input output registration/cancellation window is shown below.

Forced Input Output Registration/Cancellation

Device:

No.	Device	ON/OFF	No.	Device	ON/OFF
1	Y10	ON	17		
2	Y1E	ON	18		
3	Y1F	ON	19		
4			20		
5			21		
6			22		
7			23		
8			24		
9			25		
10			26		
11			27		
12			28		
13			29		
14			30		
15			31		
16			32		

7.2

Checking Output Signals



MELSOFT Series GX Works2 (Unset Project) - [[PRG] MAIN]

Project Edit Find/Replace Compile View Online Debug Diagnostics Tool Window Help

Navigation [PRG] M

Project

- Parameter
- Intelligent Function Module
- Global Device Comment
- Program Setting
- POU
 - Program
 - MAIN
 - Local Device Comment
- Device Memory
- Device Initial Value

Project

User Library

Connection Destination

Unlabeled Q02U Host Station 0/1Step

Forced Input Output Registration/Cancellation

Device:

Register FORCE ON Cancel Registration

Register FORCE OFF

No.	Device	ON/OFF	No.	Device	ON/OFF
1	Y10	ON	17		
2	Y1E	ON	18		
3	Y1F	ON	19		
4			20		
5			21		
6			22		
7			23		
8			24		
9			25		
10			26		
11			27		
12			28		
13			29		
14			30		
15			31		
16			32		

Update Status Batch Cancel Registration Close

Preparation for checking output signals is now completed.

Click to proceed.

7.2

Checking Output Signals

After completing the preparation for the forced input output registration/cancellation, check the output signal wiring as follows.

- (1) Using [Forced input output registration/cancellation], turn on devices Y10, Y1E, and Y1F.
- (2) Confirm that the robot start signals turn on for the respective devices Y10, Y1E, and Y1F, and the operation lamp and stop lamp light. Double-click the ON/OFF field corresponding to a device number.

Forced Input Output Registration/Cancellation

Device Register FORCE ON Cancel Registratio

Register FORCE OFF

No.	Device	ON/OFF	No.	Device	ON/OFF
1	Y10	OFF	17		
2	Y1E	OFF	18		
3	Y1F	OFF	19		
4			20		
5			21		
6			22		
7			23		
8			24		
9			25		
10			26		
11			27		
12			28		
13			29		
14			30		
15			31		
16			32		

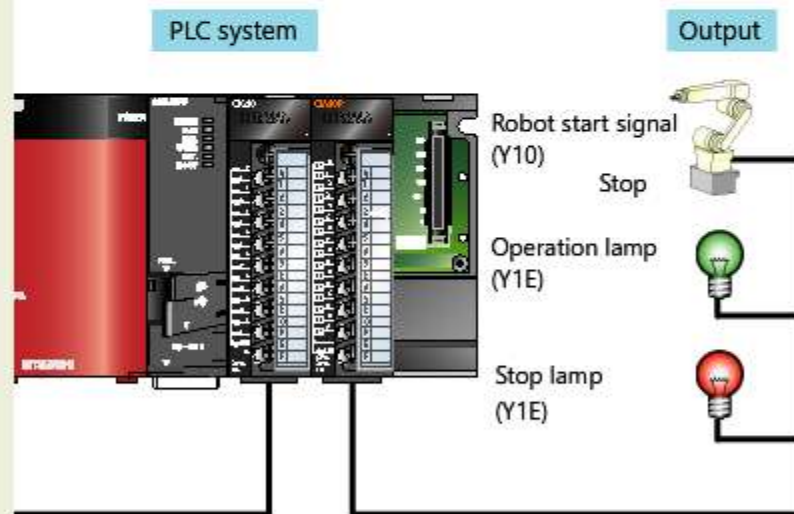

This completes the hardware setup of the MELSEC-Q series PLC system.

In this course, you have learned:

- MELSEC-Q series focuses on high performance and high scalability.
- MELSEC-Q series modules are installed on the base unit. A wide variety of modules are offered, enabling a user to choose the right module for the specific application.
- The multiple CPU function enables decentralized operation by several CPU modules. Each dedicated CPU module takes on a specialized operation such as sequence operation and positioning operation. The reduced processing requirement for each CPU module enables fast data transaction in the whole system.

Having completed this course, you now need to study the following course to be able to use the PLC system:

GX Works2 Basics: Learn programming, debugging, and writing to the CPU module.

Now that you have completed all of the lessons of the **PLC MELSEC-Q Series Basics** Course, you are ready to take the final test. If you are unclear on any of the topics covered, please take this opportunity to review those topics.

There are a total of 4 questions (11 items) in this Final Test.

You can take the final test as many times as you like.

How to score the test

After selecting the answer, make sure to click the **Answer** button. Your answer will be lost if you proceed without clicking the Answer button. (Regarded as unanswered question.)

Score results

The number of correct answers, the number of questions, the percentage of correct answers, and the pass/fail result will appear on the score page.

Correct Answers : 2

Total Questions : 9

Percentage : 22%

To pass the test, you have to answer **60%** of the questions correct.

Proceed

Review

Retry

- Click the **Proceed** button to exit the test.
- Click the **Review** button to review the test. (Correct answer check)
- Click the **Retry** button to retake the test again.

Select the modules that comprise the MELSEC-Q series system.
(Multiple selections allowed)

- CPU module
- END cover
- I/O module
- Display module
- Base unit

Select the correct steps for constructing a PLC system.

Step 1 System design

Step 2

Step 3

Step 4

Step 5 Wiring check

Select the correct steps for advance preparation before installing the PLC system and wiring.

Step 1 Confirming individual modules

Step 2

Step 3

Step 4

Step 5 Initializing the CPU module

Answer

Back

Fill in the blanks to complete the explanation of how to ground the PLC system.

Provide wherever possible.

If cannot be provided,

provide using grounding wires all of the same length.

Make the .

Answer

Back

Test**Test Score**

You have completed the Final Test. Your results are as follows.
To end the Final Test, proceed to the next page.

Correct answers : **0**

Total questions : **4**

Percentage : **0%**

Proceed

Review

Retry

You failed the test.

You have completed the **PLC MELSEC-Q Series Basics** Course.

Thank you for taking this course.

We hope you enjoyed the lessons and the information you acquired in this course will be useful in the future.

You can review the course as many times as you want.

Review

Close