

# PLC

## MELSEC iQ-R Series Basic

This course is for participants who will use the MELSEC iQ-R Series programmable controller for the first time.

This course explains the basic structure and configuration method of programmable controllers for those who will use the MELSEC iQ-R Series programmable controllers (MELSEC iQ-R Series) for the first time. Programmable controller system is generally configured in the following procedure:

1. Decide where to apply the automation system
2. Prepare the required equipment
3. Installation and wiring
4. Create various programs that execute the automated procedures

The following course is a prerequisite prior to taking this course:

1. FA Equipment for Beginners (PLCs)

The contents of this course are as follows.  
It is recommended that you start from Chapter 1.

### **Chapter 1** - Designing the programmable controller system

Learn about the MELSEC iQ-R Series, programmable controller system example, and module selection

### **Chapter 2** - Installation and wiring

Learn about module installation, I/O number assignment, and wiring

### **Chapter 3** - Creating and executing programs

Learn about connecting the CPU module to a personal computer, and programming

### **Final Test**

Pass grade: 60% or higher is required

## Introduction How to use this e-Learning tool



Go to the next page		Go to the next page.
Back to the previous page		Back to the previous page.
Move to the desired page		"Table of Contents" will be displayed, enabling you to navigate to the desired page.
Exit the learning		Exit the learning.

### **Safety precautions**

When you learn based on using actual products, please carefully read the safety precautions in the corresponding manuals.

### **Precautions in this course**

The displayed screens of the software version that you use may differ from those in this course.

This course is for the following software version:

- GX Works3 Version 1.001B

## Chapter 1 Designing the programmable controller system

This chapter explains the programmable controller system configuration and module selection based on the MELSEC iQ-R Series.

- 1.1 MELSEC iQ-R Series concept
- 1.2 MELSEC iQ-R Series system configuration
- 1.3 Programmable controller system example
- 1.4 Modules for the example sorting system
- 1.5 Module selection
- 1.6 Summary

## 1.1

## MELSEC iQ-R Series concept

Mitsubishi programmable controllers, which are also referred to as programmable automation controllers (PAC), realize automation in various control situations or applications.

The MELSEC iQ-R Series models, which were released in 2014, are a new revolutionary, next-generation controller series building a new era in automation for medium to large-scale control systems. Designed from the ground up, the control system is based on common problems faced by customers.



### Productivity



Improve productivity through advanced performance/functionality

### Engineering



Reducing development costs through intuitive engineering

### Maintenance



Reduce maintenance costs and downtime utilizing easier maintenance features

### Quality



Reliable and trusted MELSEC product quality

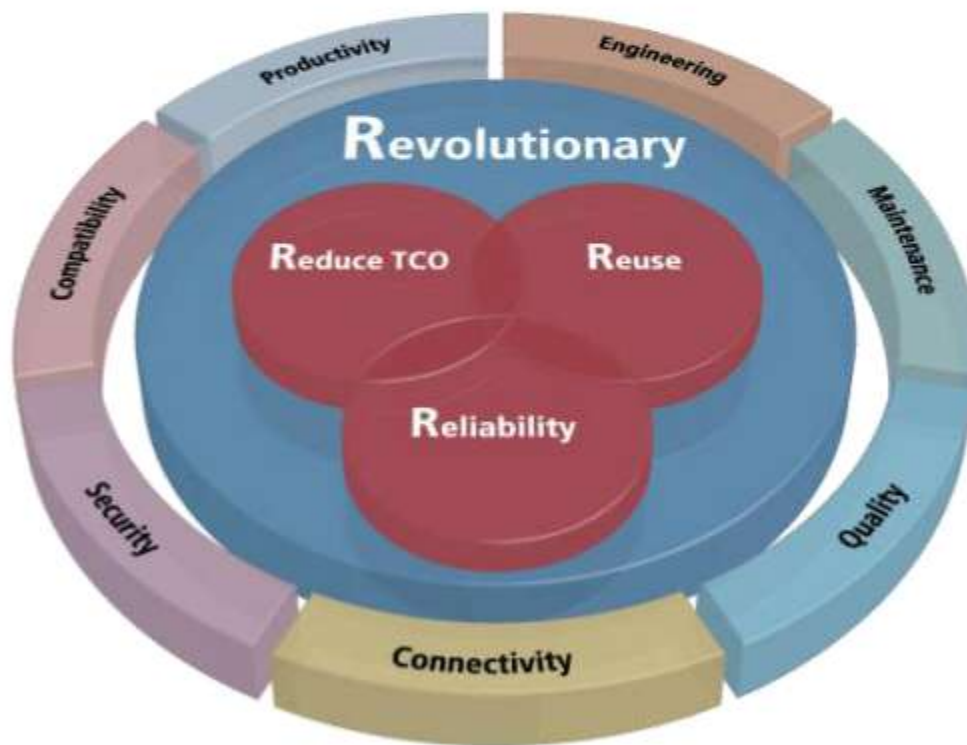

### Connectivity

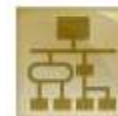

Seamless network reduces system costs

### Security



Robust security that can be relied on

### Compatibility



Extensive compatibility with existing products

## 1.2

## MELSEC iQ-R Series system configuration

This section explains about the basic MELSEC iQ-R Series system configuration. The CPU module, main base unit, and power supply module are the three essential modules required to configure a control system.

Place the mouse cursor over a module to learn about its functions. (Click on the CPU module to switch to a multi-CPU system.) After reading the functions of all the modules, click  to proceed to the next page.



Multi-CPU system

■ Extension base unit

Extends the control system to up to seven levels.



## 1.3

# Programmable controller system example

This section explains about the sorting process.

### Sorting process



Number of the crates that have passed

7

In this process, the number of incoming crates is counted.

When a crate passes in front of the sensor, the amount is incremented.

When the count is 1 to 3, crates are conveyed to line A.

When the count is 4 to 6, crates are conveyed to line B.

The proceeding 7th crate returns the guide-rails to line A.

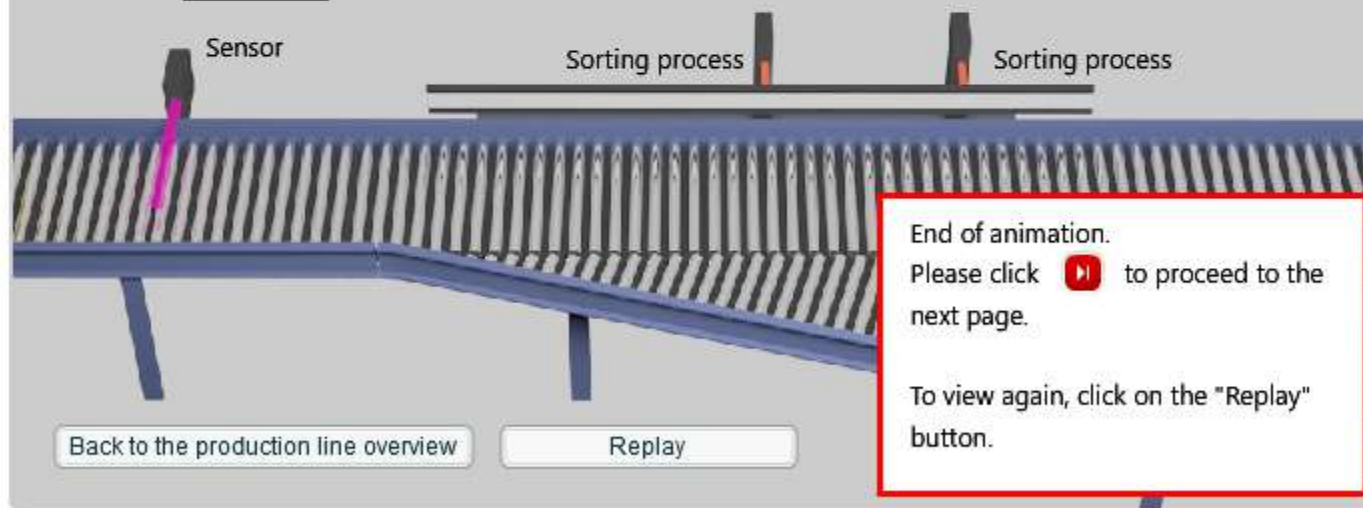

End of animation.

Please click  to proceed to the next page.

To view again, click on the "Replay" button.

## 1.4

## Modules for the example sorting system

In this example sorting system, various modules are used as shown below:

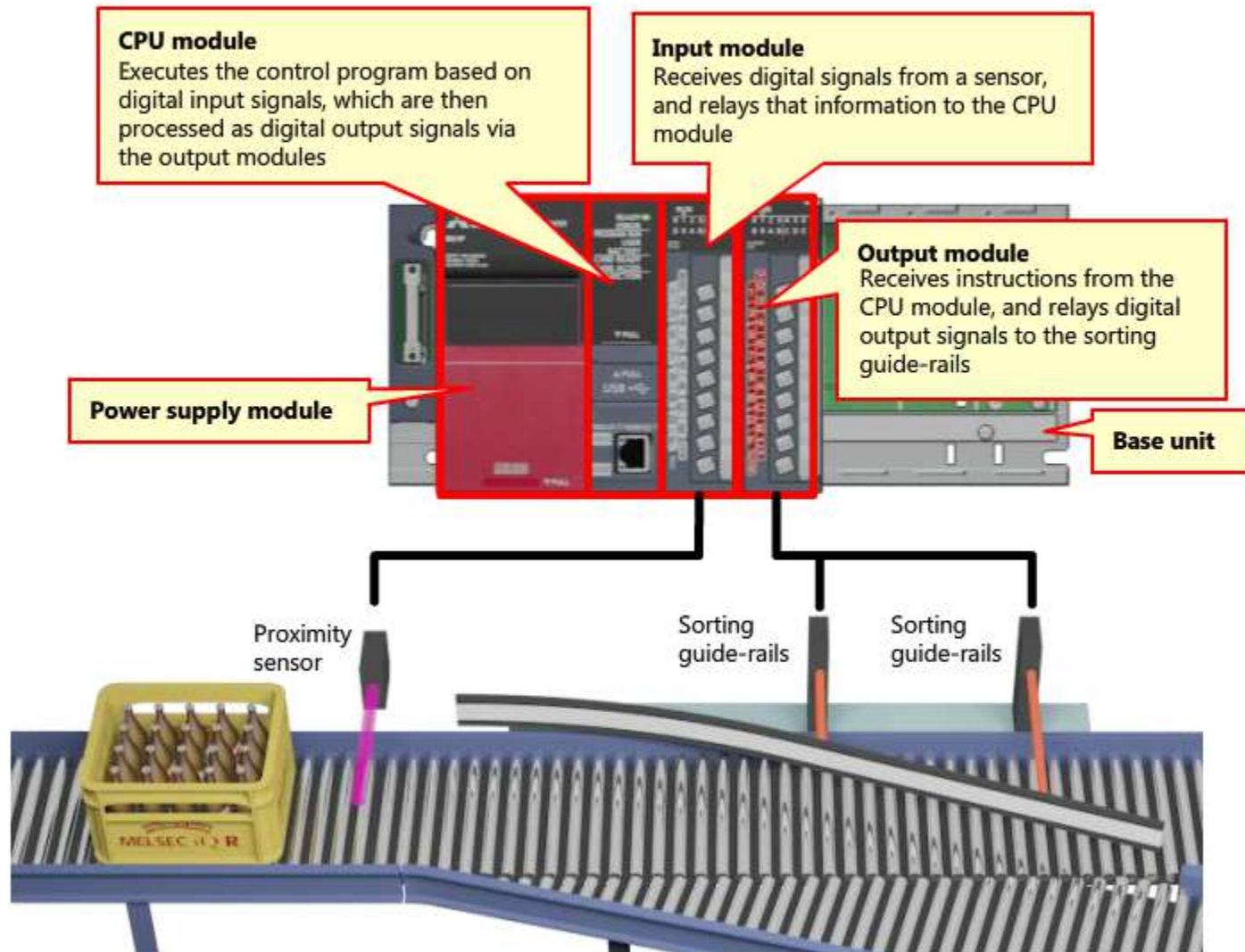

**1.5****Module selection**

The MELSEC iQ-R Series consists of a wide-range of modules that can be used for various automation applications. In the example sorting system, a digital I/O (Input and Output) module is used as the main interface to external digital signals.



Analog I/O



Motion control

## MELSEC iQ-R Series



Digital I/O

Network



## 1.5.1 I/O module selection

The following points must be considered when selecting a suitable I/O module:

- How many I/O devices are required (Number of I/O points)
- Input/output voltage

The example sorting system consists of:

- One input device (proximity sensor)
- Two output devices (sorting guide-rails)
- Input/output voltage of 24 V DC

By considering the points above, the following I/O modules are selected:

Module name	Rated input voltage	Number of input points
RX40C7	24 V DC	16 points

Module name	Rated load voltage	Number of output points
RY40NT5P	12 to 24 V DC	16 points

Sink type and source type output modules are available depending on the wiring system used. With this example, the sink type output module was selected. (The difference between the source type and sink type is explained in Chapter 2)



**RX40C7**



**RY40NT5P**

## 1.5.2 CPU module selection

The following points must be considered when selecting a suitable CPU module:

- Total number of I/O points required
- Program memory capacity

Programs are stored in the CPU module, therefore an adequate CPU module allowing for the program size should be considered. Generally a large program capacity is required for large-scale applications. In order to allow for any future additions to the control system, please select a module with a program capacity considering the extra memory requirements.

For this example, the following CPU module was selected:

Module name	Number of I/O points	Program capacity
R04CPU	4096 points	40K steps



**R04CPU**

## 1.5.3

### Base unit selection

The base unit is the main backplane to the system and holds the modules together as well as providing data communications via the system bus. The number of installable modules varies according to the capacity or slot-size of the base unit. Currently three different sizes are available, 5-, 8-, 12-slot type.

Once the control system size and required modules are decided, a suitable base unit allowing for the module I/O slot capacity is selected. In order to allow for any future additions, please select a base unit size considering the extra requirements.

For this example, the following base unit was selected:

Module name	Number of slots
R35B	5



**R35B**

## 1.5.4 Power supply module selection

When selecting a suitable power supply module, the required current consumption across the base unit has to be calculated as to provide an adequate power supply to the control system.

The concept of how power is consumed by each installed module on the base unit is shown below:

The capacity of the power supply module is depleted. Please consider the use of an extension base unit or to reduce the amount of currently installed modules.



End of animation.

Please click  to proceed to the next page.

To view again, click on the "Replay" button.

Replay

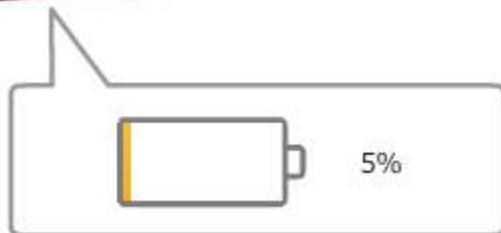

## 1.5.4 Power supply module selection

The consumption current can automatically be calculated using two different methods:

- MELSEC iQ-R Series "Model Selection System"
- Via the programming software "GX Works3"

Confirming the power supply consumption using GX Works3

Base/Cable	Slot	Model Name	Consumption Current	Total Consumption Current	Total Drop Voltage	Total I/O Points
R35B	-	R35B	0.58A	1.5A / 6.5A	-	80 Point / 4096 Point
	[Power Supply]	R61P	-			
	[CPU]	R04CPU	0.67A			
	[0]	RX40C7	0.11A			
	[1]	RY40NT5P	0.14A			

**Total Consumption Current**  
1.5A / 6.5A

Confirming the power supply consumption using the Model Selection System

MELSEC iQ-R Model Selection System Version 1.0.0

R35B

Select Main Base

CPU	0	1	2	3	4
00 0F	10 1F	20 2F	30 3F	40 4F	

No. of occupied I/O points (excluding empty slots.)  
32 / 4096 points

5 V DC current consumption  
1.5A / 6.5A

5 V DC current consumption  
1.5A / 6.5A

Please note, the Model Selection System can be obtained from your local Mitsubishi Electric or sales representative.



## 1.5.4 Power supply module selection

For the example sorting system, the total current supply required by the combination of the base unit, CPU module, input module, and output module is 1.5 A.

Therefore, the following power supply was selected:

Module name	Input current	Rated output current
R61P	100...240 V AC	6.5 A



In this chapter, you have learned:

- MELSEC iQ-R Series concept
- MELSEC iQ-R Series system configuration
- Programmable controller system example
- Modules for the example sorting system
- Module selection

Important points to consider:

Essential modules to configure a system	<ul style="list-style-type: none"><li>• CPU module</li><li>• Main base unit</li><li>• Power supply module</li></ul>
When selecting an I/O module	<ul style="list-style-type: none"><li>• Number of I/O devices</li><li>• Input/output voltage</li></ul>
When selecting a CPU module	<ul style="list-style-type: none"><li>• Total number of I/O points</li><li>• Program capacity</li></ul>
When selecting a base unit	<ul style="list-style-type: none"><li>• Number of required modules</li></ul>
When selecting a power supply module	<ul style="list-style-type: none"><li>• Total current consumption of each module used</li></ul>

## Chapter 2 Installation and wiring

This chapter explains about both the module installation and methods used for wiring.

2.1 Installation environment

2.2 Connecting the CPU module internal battery

2.3 Module installation

2.4 I/O number assignment

2.5 Wiring

2.6 Summary

## 2.1

# Installation environment

The MELSEC iQ-R Series is a programmable automation controller designed for using in industrial environments. In general, control systems are installed within a specialized control cabinet, which prevents an accumulation of dust particles and provides some level of protection against outside electrical noise interference. The order of installation is to fix the base unit first inside the control cabinet, and then to install each module as required to the base unit.



Installation in the following environments should be avoided:



- High ambient temperature



- High ambient humidity, condensation



- Exposure to intermittent or continuous vibrations, or large-force impacts



- Air containing a high concentration of dust particles
- Presence of inflammable or corrosive gas\*

For more details about supported installation environments, please refer to the general specifications in the relevant installation manuals.

\*Some modules are available with a conformal coating according to IEC60721-3-3 Class 3C2. Please contact your local Mitsubishi Electric office or sales representative for further details.

## 2.2

# Connecting the CPU module internal battery

The CPU module allows an internal battery to be connected as to ensure data retention in the event the main power supply is disconnected. When shipping, the internal battery is not connected as to conserve the battery power. Therefore, before using the CPU module, it is recommended that the internal battery is connected to the CPU module.

Please refer to the animation below showing the relevant steps of installation:



1. Open the battery compartment cover located at the bottom of the CPU module



2. Remove the cover and connect the battery connector to the socket located inside the cover



3. Reattach the cover to the CPU housing and close the battery compartment cover

## 2.3 Module installation

The modules within the MELSEC iQ-R Series are installed onto the base unit as shown below.

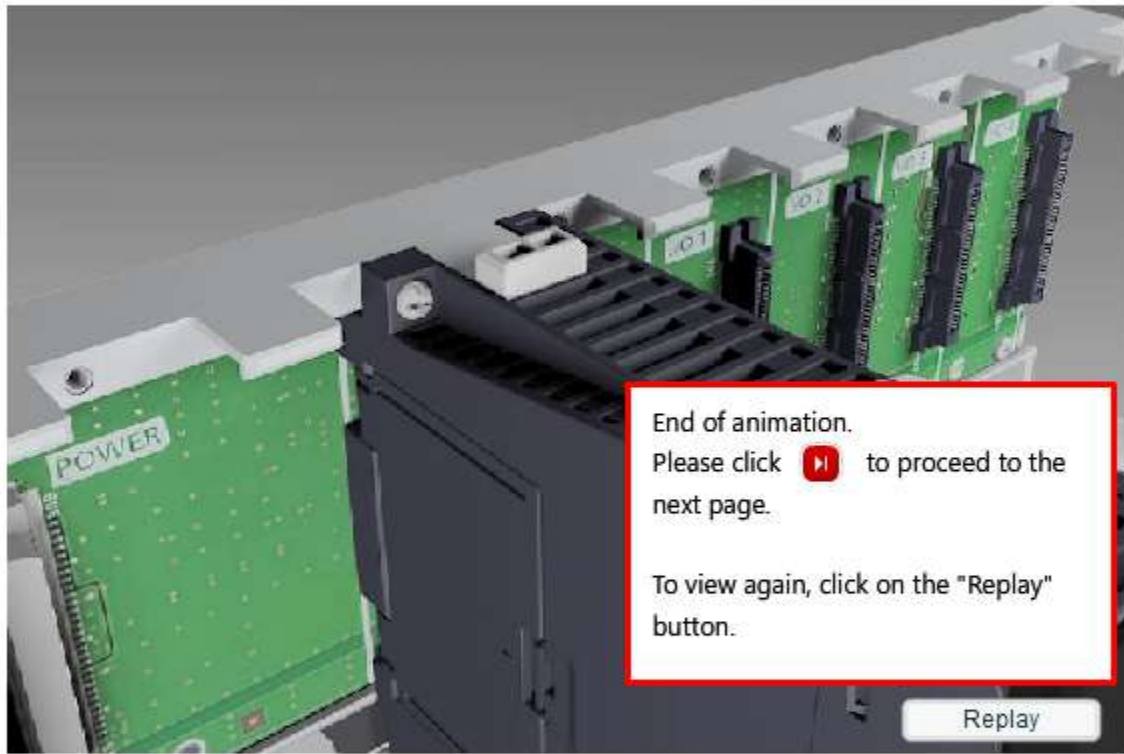

1. Align the bottom of the module with the recess located on the base unit



2. Press onto the base unit bus connector until the top catch engages the module in place



3. Tighten the module fixing bolt to provide a sturdy installation on the base unit

## 2.3.1 Modules and various slots

Different types of slots are present on the base unit for the power supply module, CPU module, and I/O modules. CPU modules can also be installed onto the first 3 I/O slots in a multiple CPU control system.

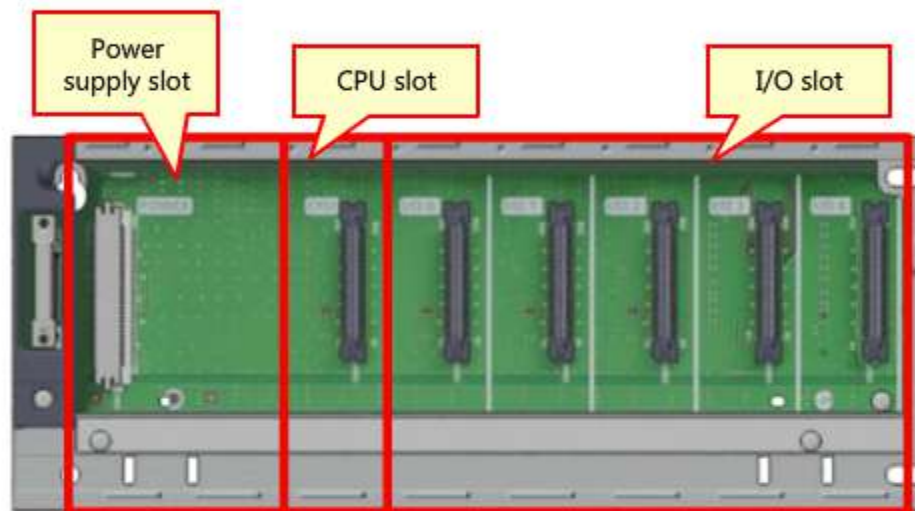

## 2.4

## I/O number assignment

- When an I/O module (except a power supply and CPU module) is installed onto the base unit, an I/O address number is automatically assigned. This address is used to identify I/O signals within the I/O module from the CPU and is allocated 16 points by default. The I/O addressing usually starts from the left most module adjacent to the last CPU module on the right.
- I/O numbers are expressed in hexadecimal and start from 0.
- "X" is appended for an input module, and "Y" is appended for an output module.
- After assignment, the correspondence between the I/O number and external device interface should be confirmed

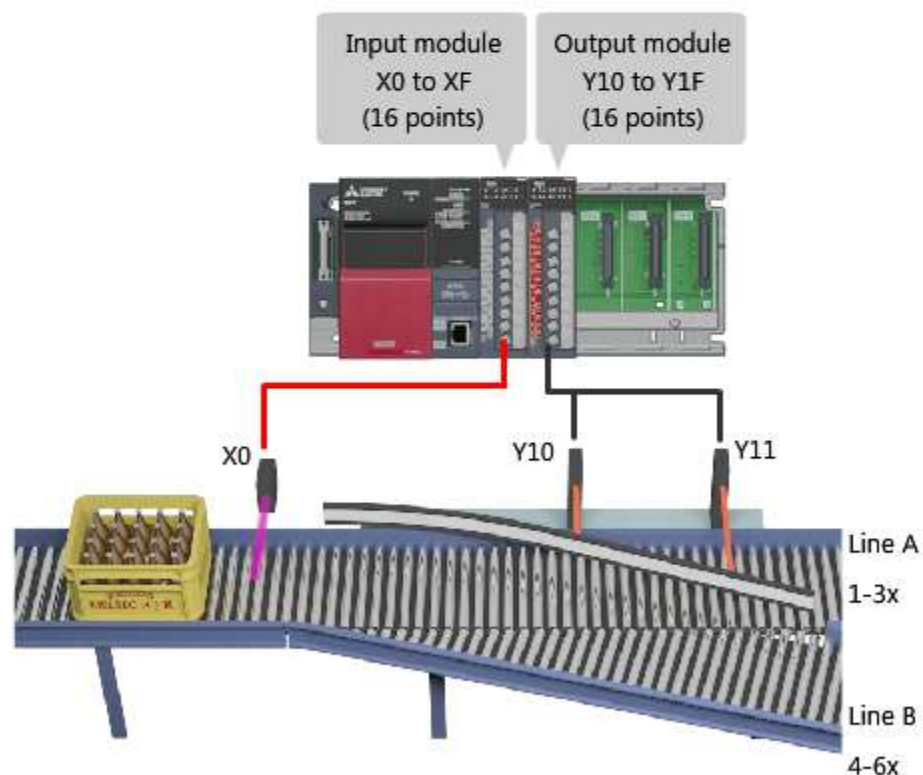

Correspondence between I/O numbers and external devices (example sorting system)

		I/O number	External device
Input module	X0 to XF (16 points)	X0	Proximity sensor, which turns ON upon detecting a crate
		X1 to XF	Not used
Output module	Y10 to Y1F (16 points)	Y10	Sorting guide-rail that pushes the crates to the other conveyor once activated (ON)
		Y11	
		Y12 to Y1F	Not used



## 2.5

## Wiring

After attaching the modules to the base unit, the power supply and external devices must be wired.

## 2.5.1 Power supply module wiring

This section explains about wiring to the power supply module.

- For wiring, the terminal cover in front of the module must be opened.
- AC power is connected to the power supply terminals L and N, respectively. (The L and N terminals are clearly labeled) Take care not to connect the AC power cables to the ERR contact terminals.
- It is recommended that both the terminals FG and LG should be earthed accordingly.

Color coding of AC mains wiring may vary according to the country used.

End of animation.

Please click  to proceed to the next page.

To view again, click on the "Replay" button.

Replay

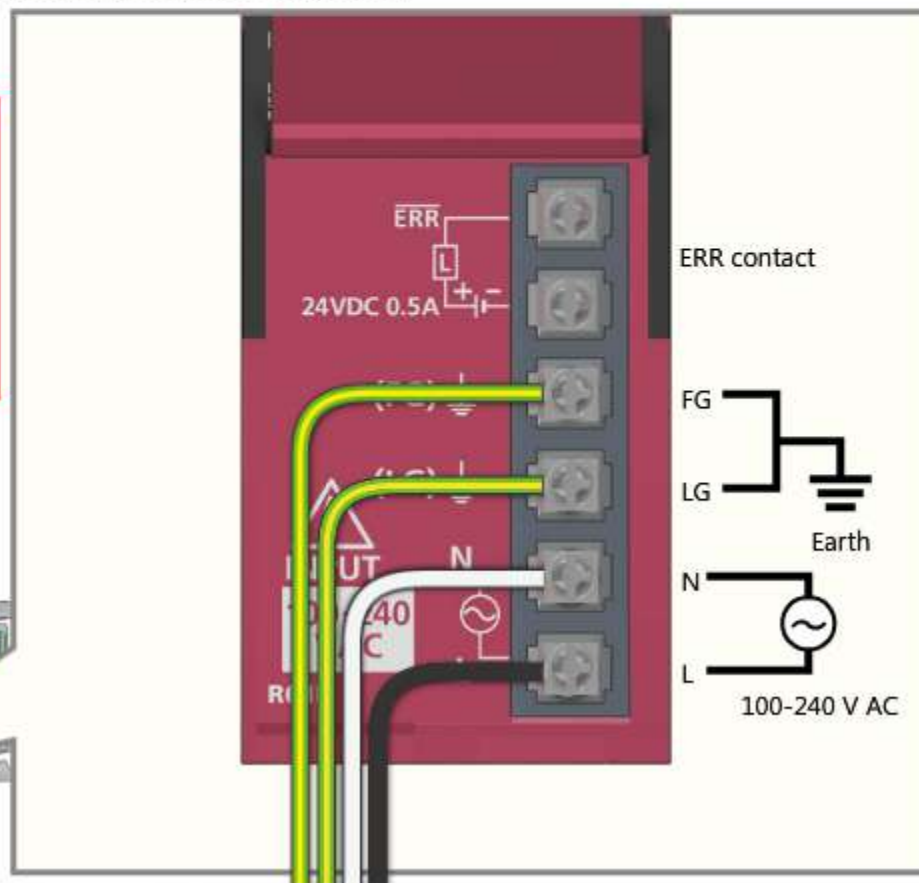



# 2.5.2 Input module wiring

An external power supply (24 V DC) is separately required in addition to the base unit power supply module. It has a single common terminal (COM), which can be wired as a positive (common positive rail is used) or negative (common negative rail is used) common. The different wiring types can be switched accordingly.

The animation illustrates the wiring of the input module.

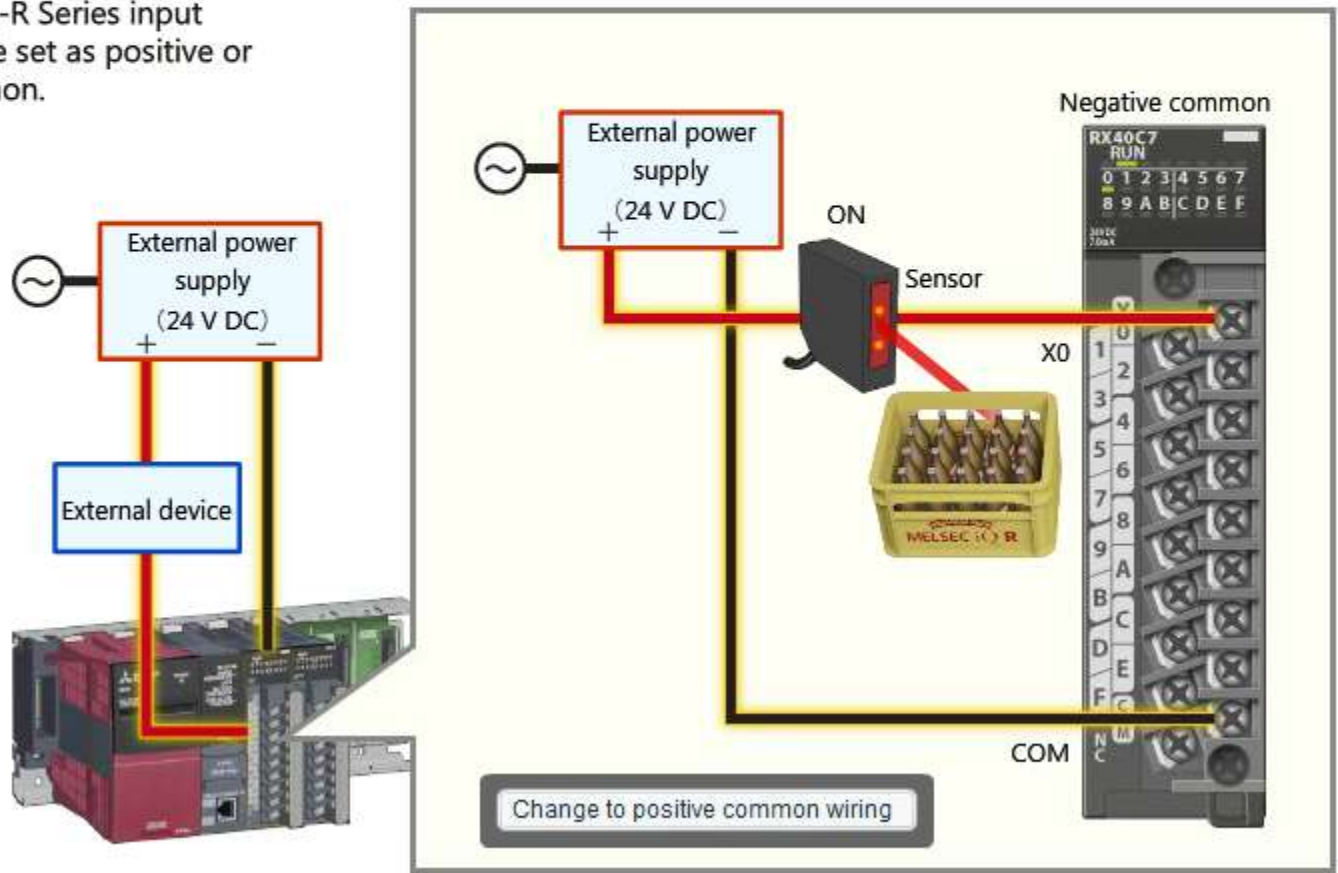
The MELSEC iQ-R Series input modules can be set as positive or negative common.



Please click the button above to switch between positive and negative common wiring. Please click  to proceed to the next.

# 2.5.3 Output module wiring

There are two distinctive ways to wire the output module, depending on the external devices used. It has a single common terminal (COM), sink wiring when the negative rail is used, and source wiring when the positive rail is used as the common. Each wiring method requires a different type of module. The output module requires an external power supply, which should be connected to either the +V or 0V terminals accordingly.

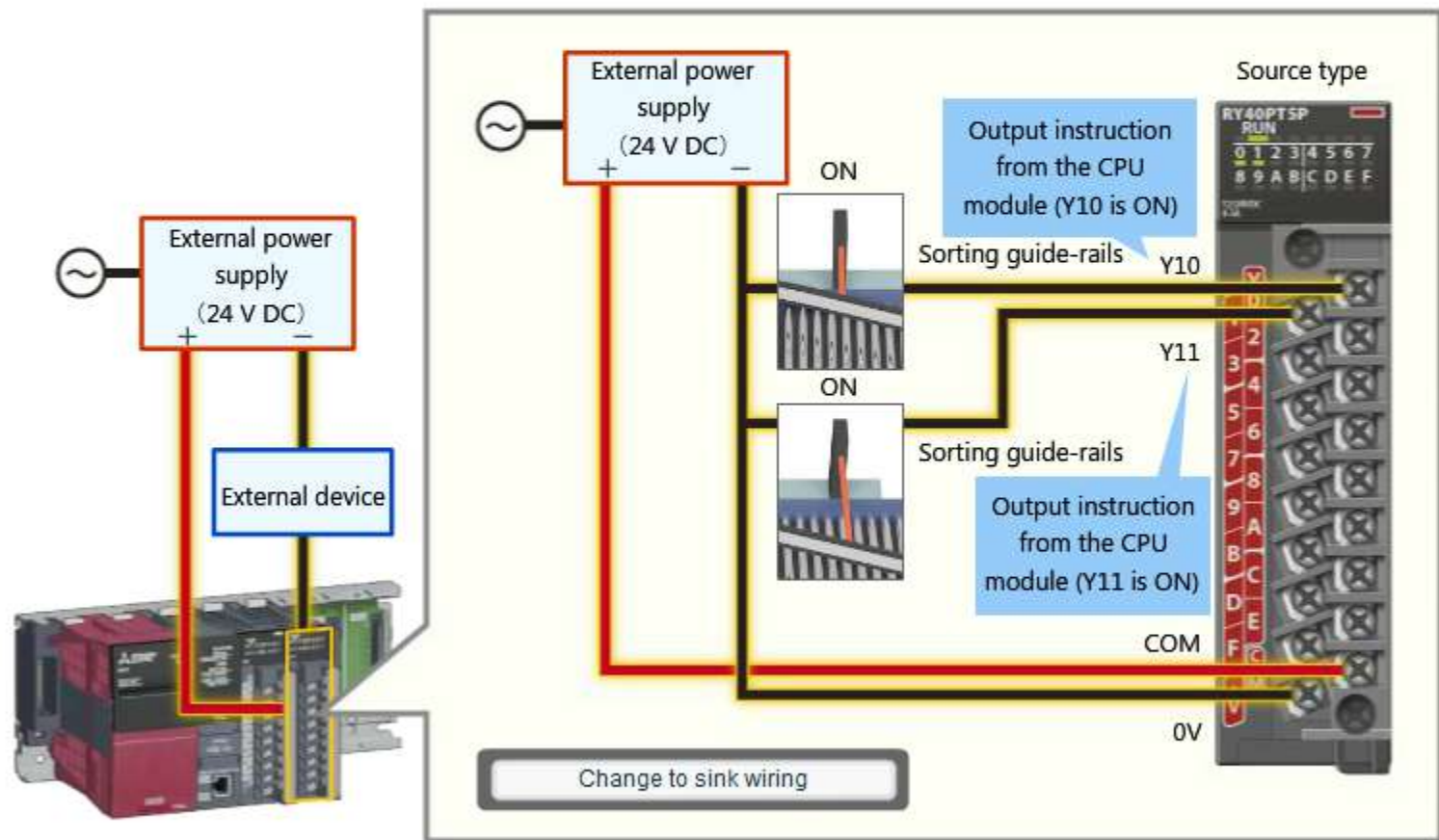

Click the button above to switch between sink and source wiring. After confirming each wiring, please click  to proceed to the next.

In this chapter, you have learned:

- Appropriate installation environment
- How to connect the CPU module internal battery
- Installation of various modules
- I/O number assignment method
- Various wiring methods

Important points to consider:

Installation environment	The MELSEC iQ-R Series control system requires to be installed in an environment as outlined in the general specifications
Connecting the internal CPU battery	Before being installed to a base unit, the CPU module needs its battery connector to be plugged in
Module installation	<ul style="list-style-type: none"> <li>• The power must be turned OFF before installing/removing a module</li> <li>• Different types of slots are present on the base unit for the power supply module, CPU module, and I/O modules (CPU Modules can also be installed onto the first 3 I/O slots in a multiple CPU control system)</li> </ul>
I/O number assignment	<ul style="list-style-type: none"> <li>• I/O numbers are assigned to the modules installed in the base unit (except CPU and power supply modules)</li> <li>• I/O numbers are assigned in increments of 16 points, and assigned from the left</li> </ul>
Power supply module wiring	<ul style="list-style-type: none"> <li>• The AC power supply is connected to the power input terminals L and N and not connected to the ERR contact</li> <li>• Always earth the power supply module terminals FG and LG</li> </ul>
I/O module wiring	<ul style="list-style-type: none"> <li>• For I/O modules, an external power supply (24 V DC) is required in addition to the base unit power supply module</li> <li>• An I/O module equipped with common terminals (COM), which can be used as input or output terminals, reduces wiring and space</li> </ul>

## Chapter 3 Creating and executing programs

This chapter explains about creating and executing programs.

3.1 Programming outline

3.2 Connecting the CPU module to a personal computer

3.3 Creating programs

3.4 Registering and executing programs

3.5 Summary

## 3.1

# Programming outline

The MELSEC iQ-R Series programmable controller requires a program to execute control tasks within the system. The program consists of a dedicated programming language such as Ladder, Structured Text (ST), and/or function block (FB).

The program is created using a personal computer installed with GX Works3, which is a dedicated engineering software for the MELSEC iQ-R Series. Once the program is created it is then uploaded to the CPU module which in turn is executed in the control CPU. Programs can be easily modified as to align with future changes in the control system configuration or control method.

For this course, the ladder programming language is used to explain basic programming practices.



Executing the program  
within the CPU module

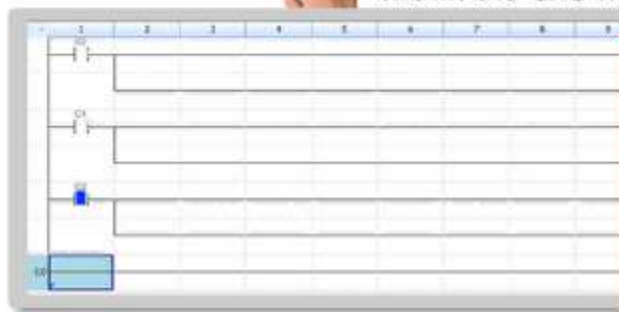

End of animation.

Please click  to proceed to the next page.

To view again, click on the "Replay" button.

Replay

1. Creating the program



2. Uploading the program to the CPU module



3. Executing the program within the CPU module

# 3.2

## Connecting the CPU module to a personal computer



Before uploading the newly created program, the CPU module has to be connected to the personal computer using GX Works3, as outlined below:

The screenshot shows the MELSOFT GX Works3 software interface. The main window is titled "MELSOFT GX Works3 (Untitled Project) - [Module Configuration]". The menu bar includes Project, Edit, Find/Replace, Convert, View, Online, Debug, Diagnostics, Tool, Window, and Help. On the left, there is a "Navigation" pane with a tree view containing categories like FB/FUN, Label, Global Label, Global, M+Global, Structured Data Type, Device, Parameter, System Parameter, R04CPU, Module Information, and specific modules like 0000:RX40C7 and 0010:RY40NT5P. The central workspace displays a rack configuration diagram with slots labeled POW, CPU 0, 1, 2, 3, and 4. The CPU 0 slot is highlighted with a blue square. On the right, the "Element Selection" pane shows a search field "(Find POU)", a "Display Target" dropdown set to "All", and a list of components under the "iQ-R Series" including Main Base, Extension Base, RQ Extension Base, PLC CPU, Motion Controller CPU, and Power Supply. A red-bordered message box in the bottom right corner contains the following text: "The CPU module is now connected to the personal computer and its initial setting is completed. Click [Next] to proceed to the next page. To replay, click the button below." A "Replay" button is located at the bottom right of the message box.

## 3.3

## Creating programs

The example sorting system requires a control program in order to operate correctly. The correspondence between the control program and the operation of the external devices that are connected to the control system are shown below.

End of animation.

Please click  to proceed to the next page.

To view again, click on the "Replay" button.

Replay

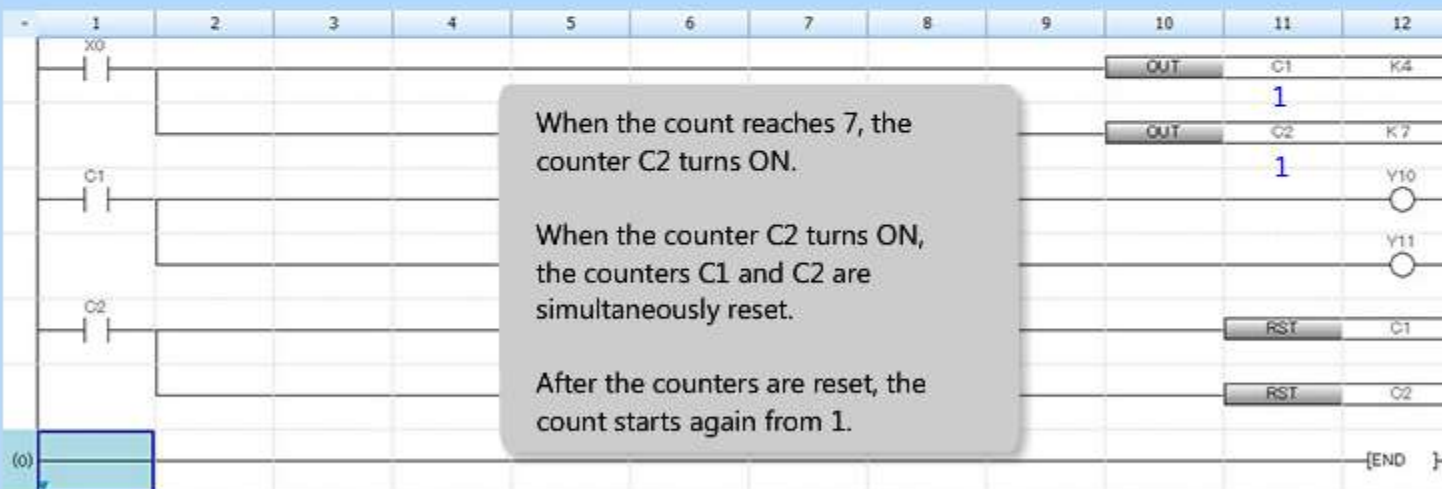
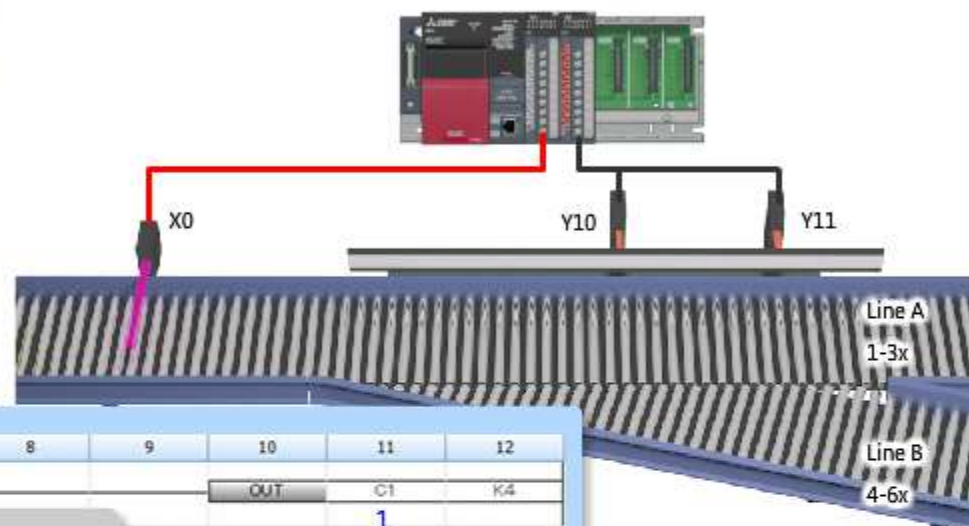

When the count reaches 7, the counter C2 turns ON.

When the counter C2 turns ON, the counters C1 and C2 are simultaneously reset.

After the counters are reset, the count starts again from 1.

Number of cases that have passed

7



# 3.3 Creating programs

The following shows the necessary steps for creating the sorting system control program. The animation shows how simple it is to implement the control tasks into program form.

MELSOFT GX Works3 (Untitled Project) - [ProgPou [PRG] [LD] 23Step]

Project Edit Find/Replace Convert View Online Debug Diagnostics Tool Window Help

ProgPou [PRG] [LD] 23Step x

Write	1	2	3	4	5	6	7	8	9	10	11	12
1	(0) Proximity sensor									OUT	C1 Counter	K4
2										OUT	C2 Counter	K7
3	(9) Counter											V10

Output

Element Selection (Find POU)

Display Target: All

Output Instruction

- DELTA[1] Pulse conversion
- DELTAP[1] Pulse conversion
- FF[1] Bit device output
- OUT[1] Out instruction
- OUT[2] Timers / Retent
- OUT[2] Long timers / Lc

The creation of a control program has now been completed.  
 Click [Next] to proceed to the next page.  
 To replay, click the button below. [Replay]

## 3.4

## Registering and executing programs

For the MELSEC iQ-R Series programmable controller be able to control the sorting system, the control program has to be uploaded to the CPU module.

The necessary steps for this are as shown below:

The screenshot shows the 'Write to PLC' dialog box in the software interface. The dialog contains the following information:

- Progress bars: 5/5 and 100/100%
- System Parameter: Writing Completed
- CPU Parameter: Writing Completed
- Module Parameter: Writing Completed
- Local Label Initial Value(MAIN): Writing Completed
- Program File(MAIN): Writing Completed
- Write to PLC : End

A red box highlights the following message:

Program upload and execution are now completed.  
Click to proceed to the next.  
To replay, click the button below.

The 'Replay' button is located at the bottom right of the dialog box.

# 3.4 Registering and executing programs

For the MELSEC iQ-R Series programmable controller be able to control the sorting system, the control program has to be uploaded to the CPU module.  
The necessary steps for this are as shown below:

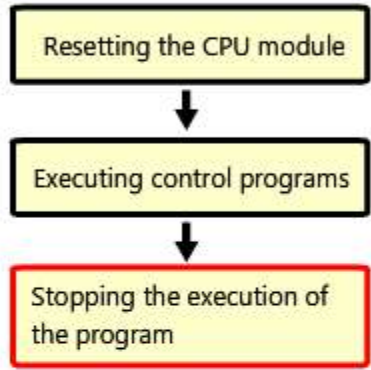

**Stopping the execution of the program**  
 P RUN LED turns off, and the execution of the control programs stops.

## 3.5

## Operation of the sorting system

The overall operation of the example sorting system is outlined below. It is also possible to change the amount of crates that are sorted and to see how the control program changes.

End of animation.

To view the animation again with a different number of conveyed cases, click on the "Replay" button shown below.

Replay

Click  to proceed to the next page.

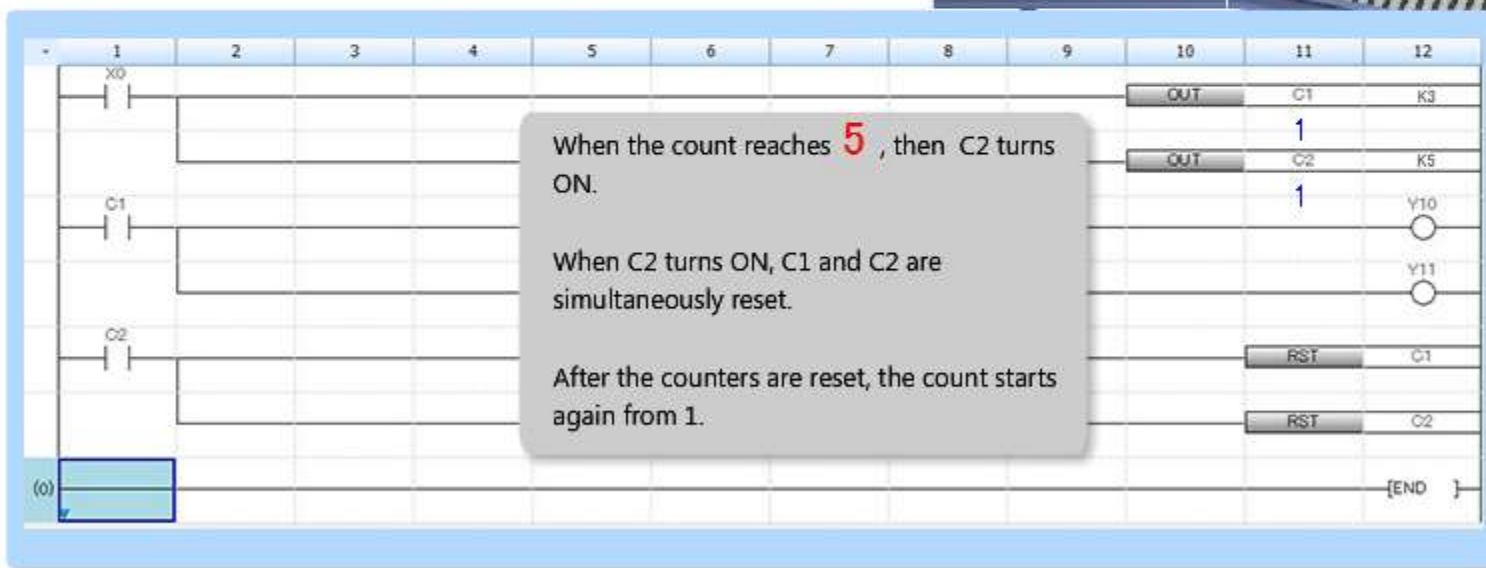
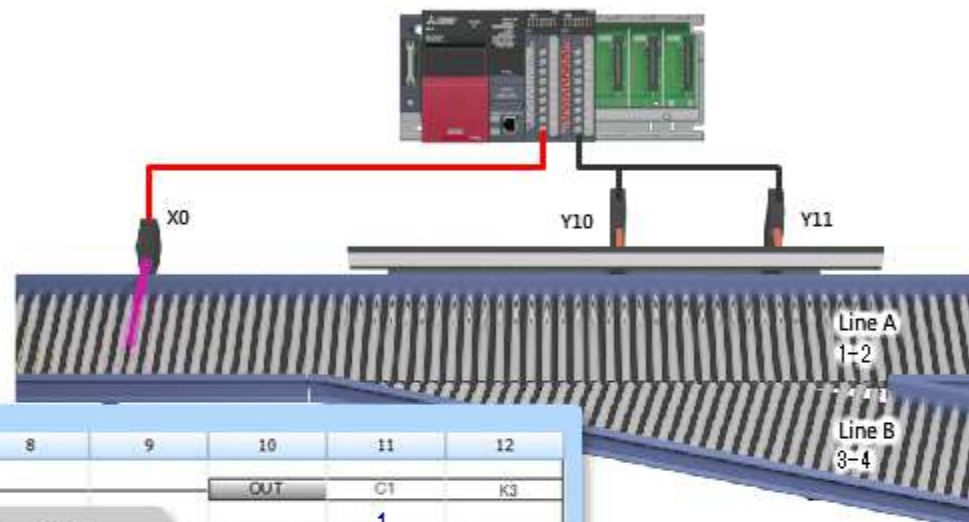

Number of crates that have passed

**5**

In this chapter, you have learned:

- The general outline for programming
- How to connect the CPU module to a personal computer
- Creating control programs
- Uploading the control program to the CPU module

Important points to consider:

Programming outline	<ol style="list-style-type: none"><li>1. Creating programs for the control system</li><li>2. Uploading the control program to the CPU module</li><li>3. Executing the program</li></ol>
Formatting the CPU module memory	It is recommended to format the CPU module memory prior to using it for the first time
Creating programs	The control program is created using GX Works3 programming software
Resetting the CPU module	Once the program has been uploaded to the CPU module, a hardware reset need to be initiated on the CPU module
Executing programs	The program stored inside the CPU module will start executing once the CPU module operating switch has been set to "RUN"

Now that you have completed all of the lessons of the **MELSEC iQ-R Series Basic** course, you are ready to take the final test. If you are unclear on any of the topics covered, please take this opportunity to review those topics.

**There are a total of 5 questions (7 items) in this Final Test.**

You can take the final test as many times as you like.

### How to score the test

After selecting the answer, make sure to click the **Answer** button. Your answer will be lost if you proceed without clicking the Answer button. (Regarded as unanswered question.)

### Score results

The number of correct answers, the number of questions, the percentage of correct answers, and the pass/fail result will appear on the score page.

Correct Answers : 2

Total Questions : 9

Percentage : 22%

To pass the test, you have to answer **60%** of the questions correct.

Proceed

Review

Retry

- Click the **Proceed** button to exit the test.
- Click the **Review** button to review the test. (Correct answer check)
- Click the **Retry** button to retake the test again.

**Test****Final Test 1****Module types**

Please select the modules essential to configure a programmable controller system. (multiple answers)

- Input module
- CPU module
- Power supply module
- Extension base unit
- Output module
- Main base unit

[Answer](#)[Back](#)

## Module selection

What needs to be considered when selecting a module? Please select an answer for each module.

Base unit  ▼

CPU module  ▼

Power supply module  ▼

- A. Program capacity
- B. Number of required modules
- C. Total consumption current of the required modules



**Installation environment**

Please select the correct description about the programmable controllers.

- Programmable controllers have a robust design and can be installed in any environment.
- Programmable controllers can operate correctly when they are installed in environments as described in the hardware specifications.

[Answer](#)[Back](#)

## Power supply module wiring

Please select the correct description about the power supply module wiring.

- The two grounding terminals of the power supply module must always be grounded.
- It is enough to ground one of the two grounding terminals of the power supply module.

[Answer](#)[Back](#)

Program execution procedure

Please select the appropriate order of procedures from program creation to execution.

- ABDC
- DACB
- BCAD

- A. Upload the control program to the CPU module
- B. Toggle the CPU module switch to "RUN"
- C. Reset the CPU module
- D. Format the CPU module memory

[Answer](#)[Back](#)

**Test****Test Score**

You have completed the Final Test. Your results are as follows.  
To end the Final Test, proceed to the next page.

Correct answers : 0

Total questions : 5

Percentage : 0%

Proceed

Review

Retry

**You failed the test.**

You have completed the **MELSEC iQ-R Series Basic** Course.

Thank you for taking this course.

We hope you enjoyed the lessons and the information you acquired in this course will be useful in the future.

You can review the course as many times as you want.

**Review**

**Close**