

LVS

Low-Voltage Circuit Breakers Basic

This course is for participants who are using Mitsubishi Low voltage circuit breakers for the first time

The chapters in this course are configured as shown below.

We recommend starting with Chapter 1 and proceeding with the course in chapter order.

Chapter 1. Outline of a Low-Voltage Circuit Breaker

Learn the basic information common to all low-voltage circuit breakers.

Chapter 2. Structure of a Low-Voltage Circuit Breaker and Earth Leakage Circuit Breaker

Learn about the structure, connections and accessories, etc., for these circuit breakers.

Chapter 3. How To Select a Low-Voltage Circuit Breaker and Earth Leakage Circuit Breaker

Learn how to select a Mitsubishi low-voltage circuit breaker or Earth Leakage circuit breaker.





Chapter 4. Circuit Breaker Life and Renewal

Learn about the circuit breaker life and renewal.

This course develops a basic understanding for each item that is essential for using Mitsubishi Electric's power distribution and control devices.

This section is part of a wide series of courses, and focuses on the low-voltage circuit breaker.

Following is an explanation of how to use the graphical user interface.

Go to the next page		Go to the next page.
Back to the previous page		Back to the previous page.
Move to the desired page		"Table of Contents" will be displayed, enabling you to navigate to the desired page.
Exit the learning		Exit the learning. Window such as "Contents" screen and the learning will be closed.

Safety Instructions

When your study includes using the actual product, we ask that you carefully read the "Safety Instructions" described in the product manual, and use the product in a proper manner while paying careful attention to the safety issues.

Here you will learn the basic information common to all low-voltage circuit breakers.

Chapter 1 Study Content

- 1.1 Types of low-voltage circuit breakers
- 1.2 Installation of low-voltage circuit breakers
- 1.3 Selection of low-voltage circuit breakers
- 1.4 Working environment, transportation, storage
- 1.5 Summary of chapter

Low-voltage circuit breaker is the generic name for circuit breakers used in a low-voltage electric circuit at either a)1000 V AC or less, b)1500 V DC or less, mainly to protect wiring and devices.

Some of the different types of low-voltage circuit breaker available are as follows,;

- **Molded-Case Circuit Breaker : MCCB**
- **Air Circuit Breaker : ACB**
- **Miniature Circuit Breaker : MCB**
- **Earth Leakage Circuit Breaker : ELCB**
- **Circuit Breaker for Equipment : CBE**

The following IEC Standards apply to low-voltage circuit breakers.

There are multiple product standards for the same type of device.

The standards system applies to industrial use (a skilled person handling the device) and household use (a person handling device has no experience).

IEC standard No.	Typical abbreviation	IEC standard name	Example product from Mitsubishi Electric
IEC 60947-2	MCCB, ACB	Low-voltage switchgear and control gear - Part 2: Circuit-breakers	NF type low-voltage circuit breaker AE type low-voltage air circuit breaker
IEC 60947-2 Annex B	ELCB	Low-voltage switchgear and control gear - Part 2: Circuit-breakers Annex B: Circuit-breakers incorporating residual current protection	NV type earth leakage circuit breaker
IEC 60898-1/-2	MCB	Circuit-breakers for overcurrent protection for household and similar installations	BH-D type miniature circuit breaker
IEC 61008-1	RCCB	Residual current operated circuit-breakers without integral overcurrent protection for household and similar uses (RCCBs)	BV-D type earth leakage circuit breaker
IEC 61009-1	RCBO	Residual current operated circuit-breakers with integral overcurrent protection for household and similar uses (RCBOs)	BV-DN type earth leakage circuit breaker
IEC 60934	CBE	Circuit-breakers for equipment	CP type circuit protector

When installing a low-voltage circuit breaker, the standards and rules of the respective country will apply. A low-voltage circuit breaker and ELCB that comply with those requirements must be used and the installation obligations adhered to. For example, when installing a device in accordance with IEC 60364 Low-voltage electrical installations, the following requirements will apply to the low-voltage circuit breaker and the ELCB. These regulations must be complied with.

[Overcurrent protection]

IEC60364-1 (Low-voltage electrical installations)

131.4 Protection against overcurrent

Persons and livestock shall be protected against injury, and property shall be protected against damage, due to excessive temperatures or electromechanical stresses caused by any overcurrents likely to arise in live conductors.

IEC60364-4-43 (Protection for safety-Protection against overcurrent)

430.3 General requirement

A protective device shall be provided to break any overcurrent in the circuit conductors before such a current could cause a danger due to thermal or mechanical effects detrimental to insulation, connections, joints, terminations or the surroundings of the conductors.

[Electric shock protection]

IEC60364-1 (Low-voltage electrical installations)

131.2.2 Fault protection (protection against indirect contact)

Persons and livestock shall be protected against dangers that may arise from contact with exposed-conductive-parts during a fault. This protection can be achieved by one of the following methods:

- Preventing a current resulting from a fault from passing through the body of any person or any livestock
- Limiting the magnitude of a current resulting from a fault, which can pass through a body, to a non-hazardous value
- Limiting the duration of a current resulting from a fault, which can pass through a body, to a non-hazardous time period.

IEC60364-4-41 (Protection for safety-Protection against electric shock)

415.1 Additional protection

415.1.1 The use of RCDs with a rated residual operating not exceeding 30 mA is recognized in a.c. systems as additional protection in the event of failure of the provision for basic protection and/or the provision for fault protection or carelessness by users.

The following concept can be applied when selecting a low-voltage circuit breaker.

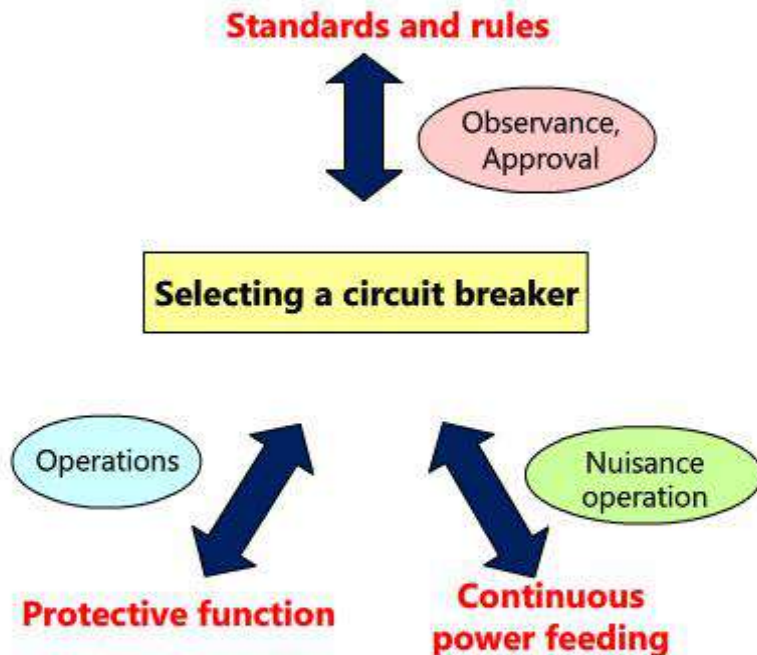

(1) **Selection = Observing requirements for standards and rules**

When using a low-voltage circuit breaker, each country in the world has set standards and restrictions regarding electrical facilities, and the rating value must be selected to comply with those requirements. Rules and industrial standards define the criterion of performance of the low-voltage circuit breaker. There are many countries which restrict the manufacture and distribution of these protective devices. The indication of an Approved mark is required in countries that have a national Compulsory Certificate system, such as China CCC, Korea KC, EU CE Marking, US NRTL and Japan <PS>E.

(2) **Selection = Protective coordination**

What type of protective functions should be used when using a protective device such as a low-voltage circuit breaker? There are two sides to a protective function. One is a "function that accurately operates when necessary (does not cause non-operation state)", and the other is "a function that does not operate when not necessary (does not perform nuisance operations)".

The standard usage state of the circuit breaker is shown below.

Standard working conditions

- Working ambient temperature.: **-10 °C to 40 °C**

A reduction in the working current is required if the ambient temperature exceeds 40 °C.

- Relative humidity: **50% (40 °C max.)** or less with no dewing.
- Altitude: **2000 m or less**
- Environment : Free of excessive moisture, oil vapors, smoke, dust, salt, corrosive substances, vibration or impact, etc.

The basic precautions for transportation are shown below.

- Packing and transportation shall be carried out with care



Never drop the packing.

- Don't bring the breaker by holding the flash plate for carrying.



Carrying in this manner is dangerous as the breaker may drop.

- Don't bring the breaker up with holding the wires for carrying.



Holding on the attached lead wires of internal accessories for carrying as unreasonable force is applied to the attached wires.

The following precautions apply when storing the device.

• **Storage temperature**
-25 °C to 55 °C

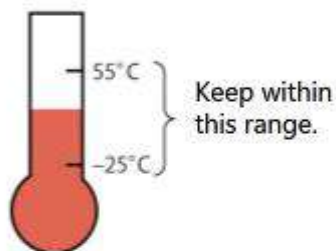

• **Avoid moisture**
(Relative humidity:50%max)



- Do not store for a long time in a humid place.
- Control the product so that dew does not form.

• **Avoid corrosive gases.**



- Do not store the product in an atmosphere with acidic or ammonia gas.
H₂S 0.01ppm or less
SO₂ 0.05ppm or less
NH₃ 0.25ppm or less

• **Store in the OFF or tripped state.**

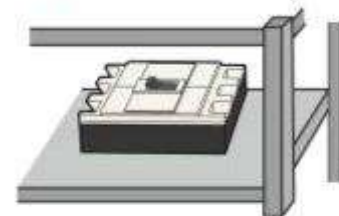

Store the product in OFF or tripped state.

• **Avoid direct sunlight.**



If the temperature rises because of direct sunlight, the breaker could operate by malfunction or the nameplate and molded case could discolor, etc.

• **Keep in the original packing case for storage.**



• **Store in a dust-free environment.**

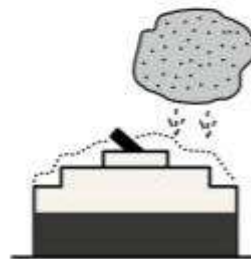

The following were studied in this chapter.

- There are many types of low-voltage circuit breakers(i.e. ACB, MCCB, ELCB, MCB and CBE) so select the most appropriate one that matches the intended use.
- Low-voltage circuit breakers are used for overcurrent protection and electric shock protection in low-voltage electrical circuits as specified by the laws of the country it is being used in.
- When selecting a low-voltage circuit breaker, standards and rules must be observed as well as considerations regarding the protective coordination.
- The working environment greatly affects the performance and life of the low-voltage circuit breaker.

The following chapters describe low-voltage circuit breakers and ELCBs in detail.

Please take the review test for this chapter to confirm your understanding.

In the following chapters you will learn about the specifics of low-voltage circuit breaker and earth leakage circuit breakers.

Fill in the blanks with the term that is most appropriate.

When installing a low-voltage circuit breaker, there are (a) specified in each country. A low-voltage circuit breaker and an ELCB that comply with those requirements must be (b).

a) standards and rules ▼

b) used ▼

Answer

Back

Correct answer - please continue or press "y" to click on the screen.

Fill in the blanks with the term that is most appropriate.

When selecting a circuit breaker, the following three factors must be considered (a), (b), and (c)

- A, a) cost performance
b) operating characteristics
c) breaking capacity
- B, a) standards and rules
b) protective function
c) continuous power feed
- C, a) air circuit breaker
b) molded-case circuit breaker
c) earth leakage circuit breaker

Answer

Back

Correct answer - please continue or press "y" to click on the screen.

Fill in the blanks with the term that is most appropriate.

The working environment of the circuit breaker greatly affects its performance and life, so care must be taken to operate within the specification set.

The standard working temperature range - is $-5\text{ }^{\circ}\text{C}$ to (a).

a)

Answer

Back

Correct answer - please continue or press "y" to click on the screen.

This chapter explains the following contents regarding low-voltage circuit breaker and ELCB; the most typical low-voltage electrical circuit overcurrent/short circuit protection and ground fault/electric shock devices.

Chapter 2 Study Content

- 2.1 Necessity of low-voltage circuit breaker
- 2.2 Circuit breaker structure and operation
- 2.3 Types of earth leakage circuit breakers
- 2.4 Installation and connection
- 2.5 Accessories
- 2.6 Summary of chapter

Using a motor circuit as an example, the following functions are the most basic required of an electrical circuit.

- (1) **Disconnection (switching)**
- (2) **Short-circuit protection**
- (3) **Switching control**
- (4) **Overload protection**

Refer to the photos on the right.

Generally, the circuit breaker covers functions (1) and (2), and the magnetic switch covers functions (3) and (4).

If earth leakage protection (5) is required, the ELCB covers functions (1), (2) and (5).

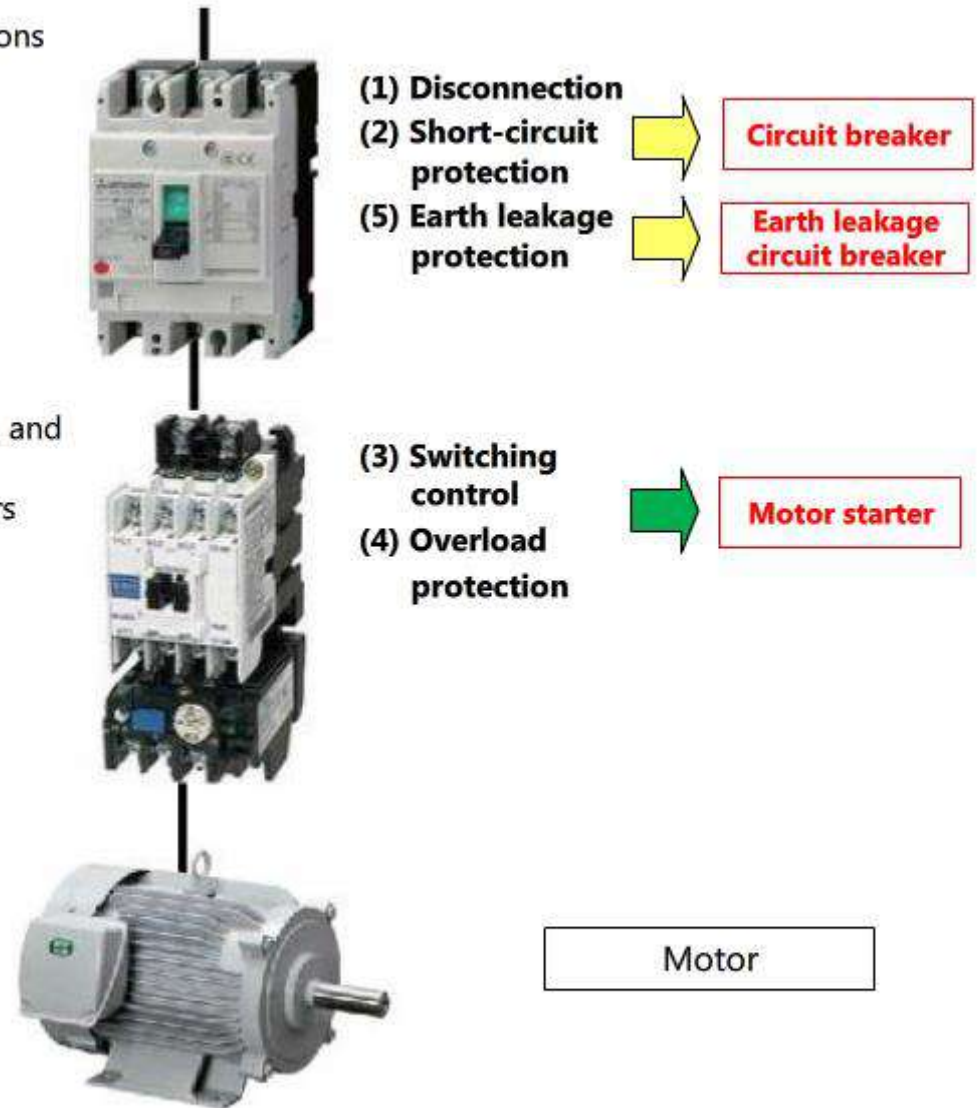

When a ground fault or earth leakage accident occurs in the electrical circuit, if the ground fault leakage current is very small compared to the electrical circuit's load current, it is difficult to protect against ground fault accidents with MCCBs.

An ELCB that can detect very small ground fault current (leakage current) is recommended for electrical shock protection.

Type of earthing system	TN system			TT system	IT system
	TN-C system	TN-S system	TN-C-S system		
Typical arrangement					
Earth leakage protective device	- MCCBs Not ELCBs	- MCCBs - ELCBs	- MCCBs - ELCBs (except in TN-C zone)	- ELCBs	- Insulation monitoring device + MCCBs

ACB



This section explains the structure and operating principle of a low-voltage circuit breaker.

The appearance of the low-voltage circuit breakers ACB, MCCB, ELCB and MCB are shown below.

Each cover is white so it can be coordinated with the low-voltage incoming power panel and the control panel.

MCCB



ELCB



MCB



(1) Low-voltage circuit breaker:

The main components of the MCCB are explained below.

- Toggle link mechanism that has a "spring" (often a tension spring) to act as the source of the switching force and tripping force. The "**Switching mechanism**" opens and closes the contact with a "**Handle**".
- "**Overcurrent tripping device**" that trips the switching mechanism in reaction to the overload current or short-circuit current.
- "**Arc extinguishing device**" that extinguishes the arc generated between a pair of contacts when the current is cut off.
- "**Terminal**" that connects the external wire and conductor.
- "**Contact**" that opens and closes the circuit.
- "**Molded-case**" insulator that compactly stores these components. (**Base** and **Cover**)

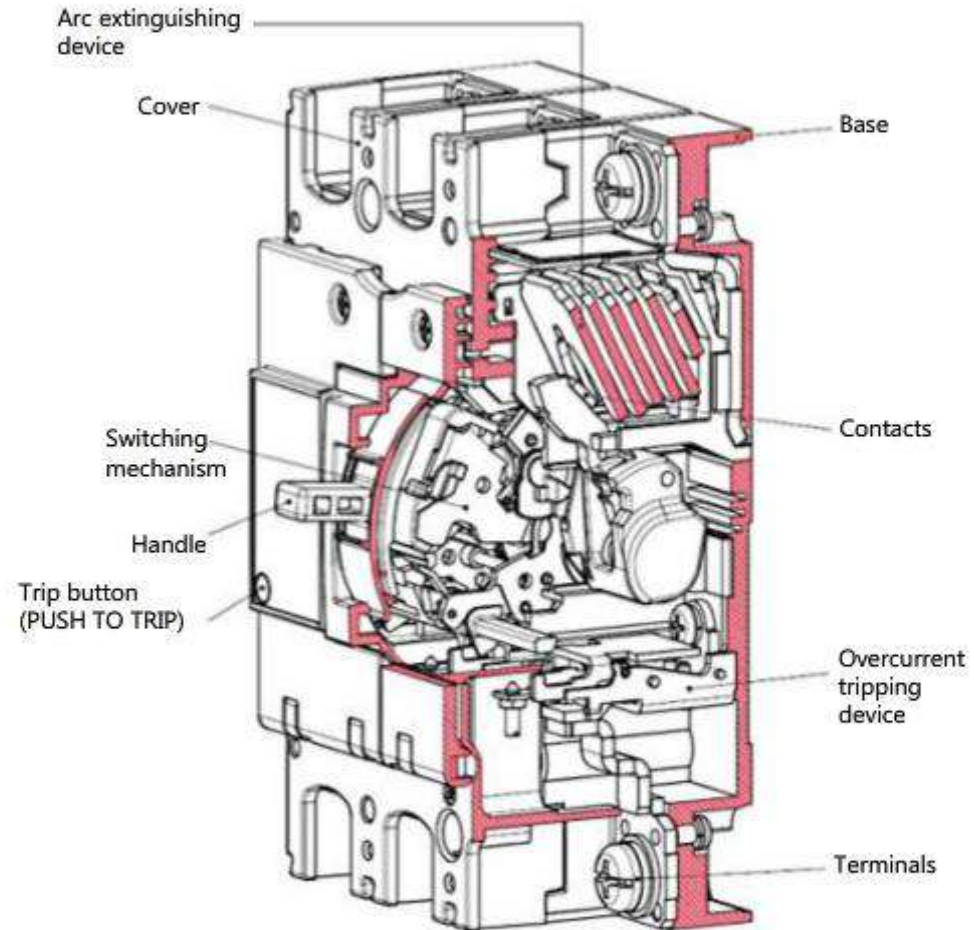

(1) The main components of the ELCB are the same as the low-voltage circuit breaker.

- **“Switching mechanism”** that opens and closes the contact with a **“Handle”**
- **“Overcurrent tripping device”** that trips the switching mechanism in reaction to the overload current or short-circuit current
- **“Arc extinguishing device”** that extinguishes the arc generated when the current is cut off
- **“Terminal”** that connects the external wire and conductor
- **“Contact”** that opens and closes the circuit

Elements unique to the ELCB include:

- **“Earth-leakage tripping device”** that trips the ELCB in reaction to an earth-leakage current
- **“Earth-leakage indication device”** that indicates that the device functioned at an earth-leakage accident
- **“Test button”** for confirming operation in the event of an earth-leakage fault, etc.

In the same manner as the circuit breaker,

- These components are assembled into an integrated **“Molded case”** (**Base** and **Cover**)

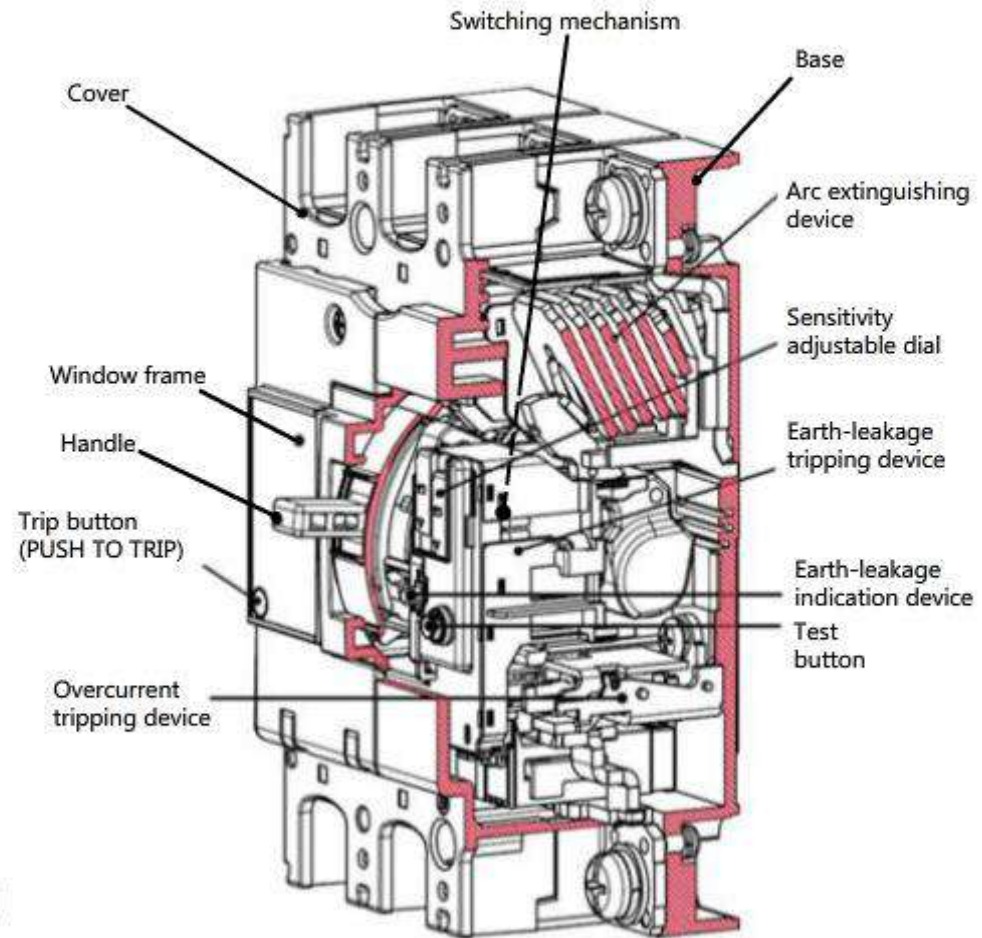

The main components of the air circuit breaker (ACB) are explained below.

- **"Closing spring"** that acts as the source of the circuit breaker's closing force, and the **"Closing and tripping mechanism"** that switches
- **"Electronic trip coil"** and **"Current sensor coil, Power supply CT"** that detect the overload current or short-circuit current and trip the breaker
- **"Contact"** that opens and closes the circuit
- **"Arc extinguishing device"** that extinguishes the arc generated between several contacts when the current is cut off
- **"Terminal"** that connects the external wire and conductor
- **"Auxiliary contact: AX"**, **"Shunt trip: SHT"**, **"Closing coil: CC"**, **"Under-voltage tripping device: UVT"** and **"Motor closing unit: MD"** which are internal accessories incorporated with in the ACB.
- **"Draw-out frame"** and **"Draw-out mechanism"** that inserts and draws out the ACB main unit.

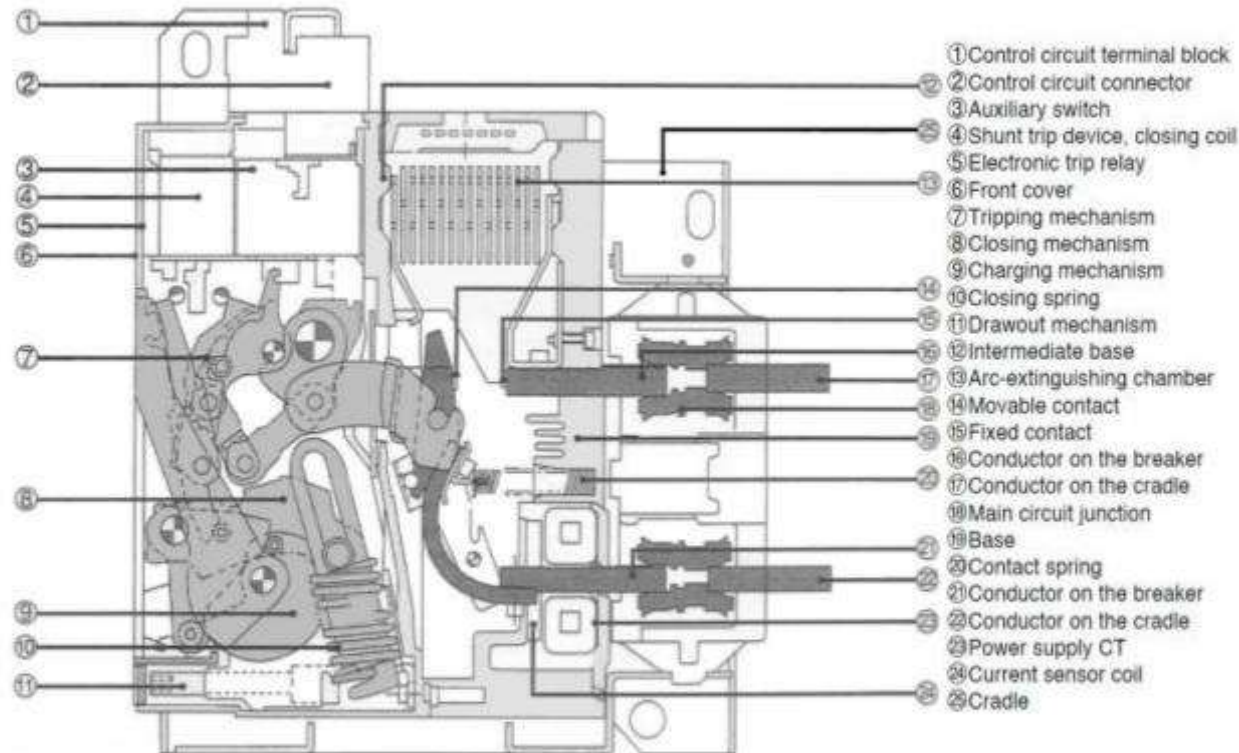

(1) Miniature circuit breaker:

The main components of the MCB are the same as the MCCB, but the width is approx. 18 mm/pole, so the product is mounted on an IEC rail.

- Toggle link mechanism that has a "spring" (tension spring) to act as the source of the switching force and tripping force, and the "**Operation mechanism**" that opens and closes the contact with a "**Handle**".
- "**Overcurrent tripping device**" that trips the switching mechanism in reaction to the overload current or short-circuit current.
- As opposed to the MCCB, there is no trip position.
- "**Arc extinguishing device**" that extinguishes the arc generated between a pair of "**Contacts**" when the current is cut off.
- "**Terminal**" that connects the external wire and conductor.
- "**Mold-case**" insulator that stores these components.

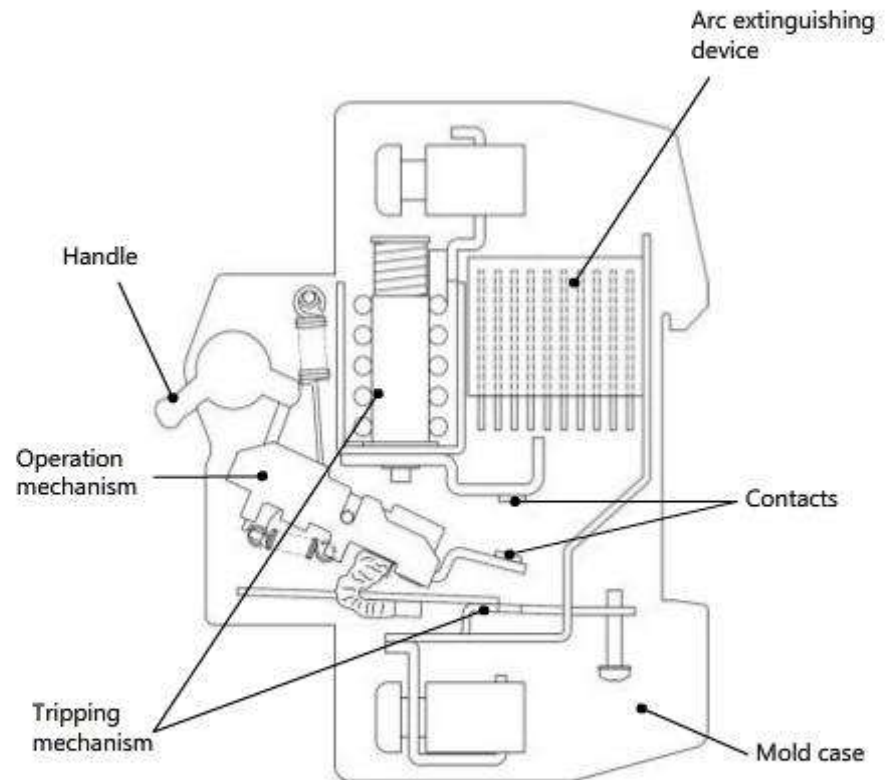

These circuit breakers are categorized according to their difference in **overcurrent tripping device's** operation theory and structure.

- **Thermal magnetic type**
- **Hydraulic magnetic type**
- **Electronic type**

The most common type is the thermal magnetic type. This forms a **time-delay tripping characteristic** using the **inverse time-characteristics** of the bimetal, however it can also form **instantaneous tripping characteristic similar** to the **instantaneous characteristics** of the electromagnet. An example of the **thermal magnetic type** operating characteristics is shown on the right.

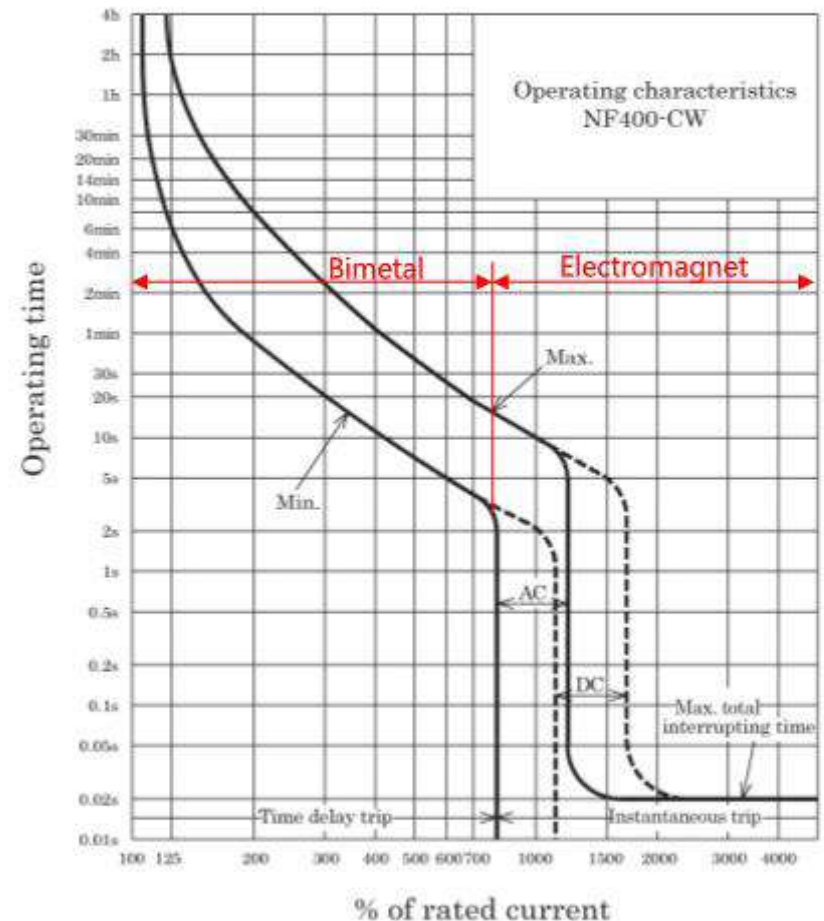

The miniature circuit breaker is equipped with a **thermal magnetic type** overcurrent tripping mechanism. The **time-delay tripping characteristic** is formed using the **inverse time-characteristics** of the bimetal, while the **instantaneous tripping characteristic** are similar to the **instantaneous characteristics** of the electromagnet.

Operating characteristics curve:

The types are divided according to the MCB instantaneous operation characteristics.

B type: Instantaneous
3-5 × rated current

C type: Instantaneous
5-10 × rated current

D type: Instantaneous
10-20 × rated current

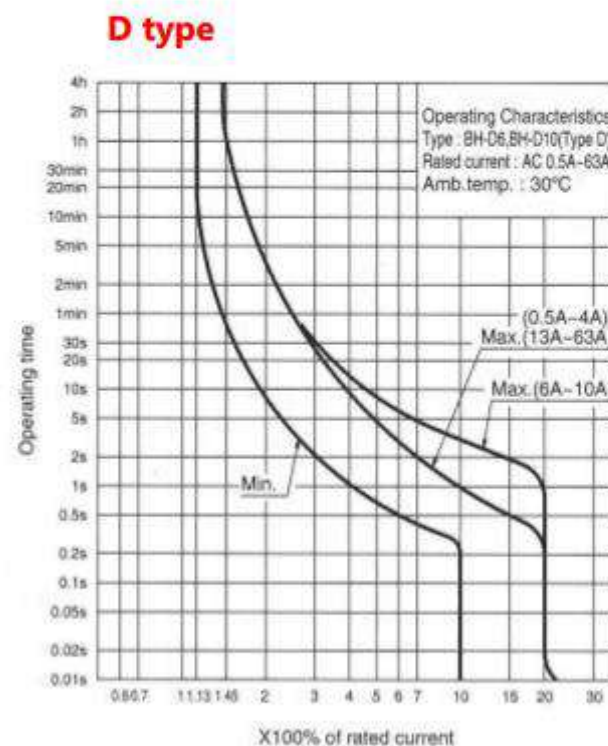
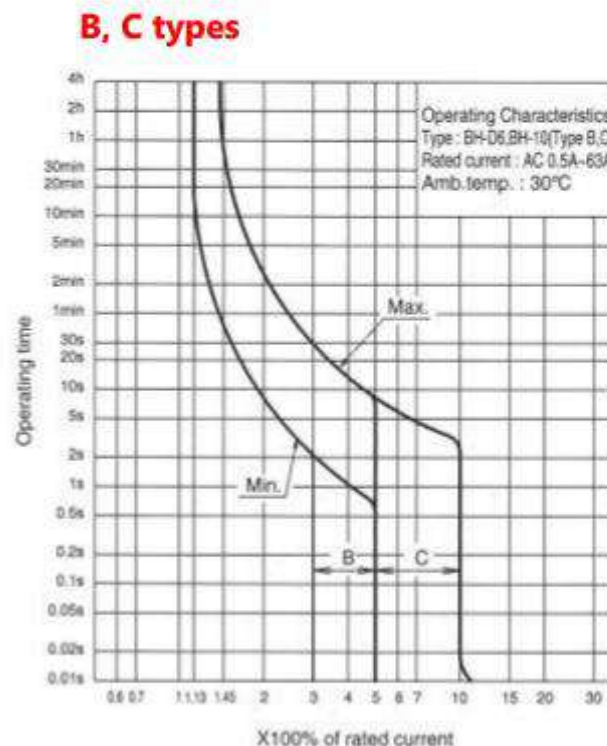

The operation principle and structure of the MCCB **electronic tripping mechanism** is shown below.

1. The current that flows to the circuit breaker is **detected by the current detection CT**.
2. The current signal is **converted by the special IC into RMS value signal or peak signal** (according to the current value), and is compared with the pickup current setting and setting time.
3. When the signal reaches the trip conditions, the **trip coil** is energized by the trigger signal and the circuit breaker is tripped.

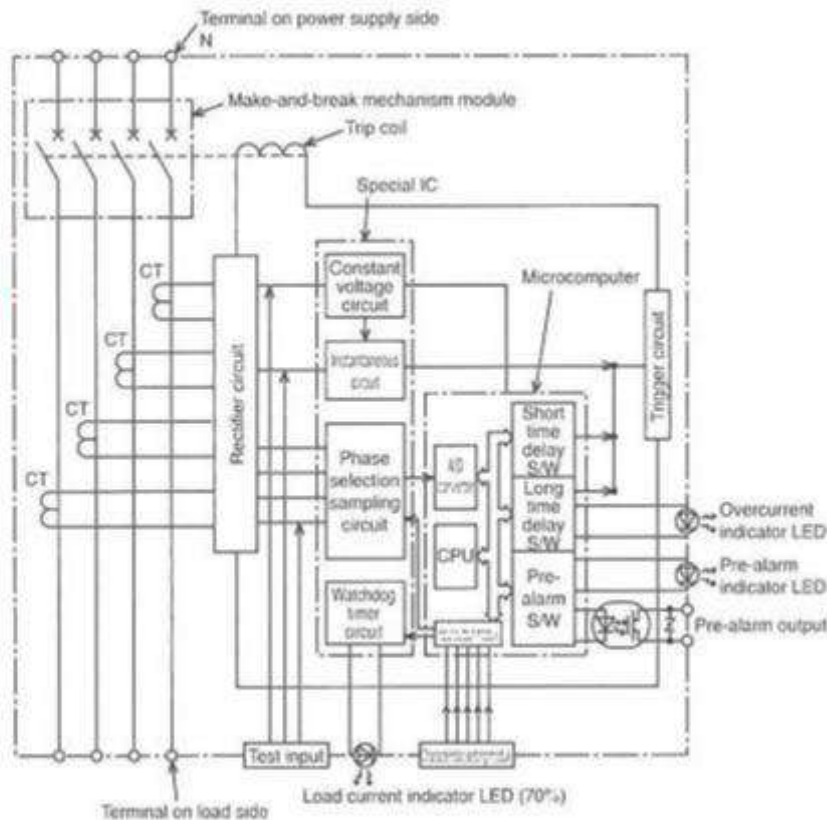

With the electronic type, both the pickup current and time of the characteristics curve can be adjusted.

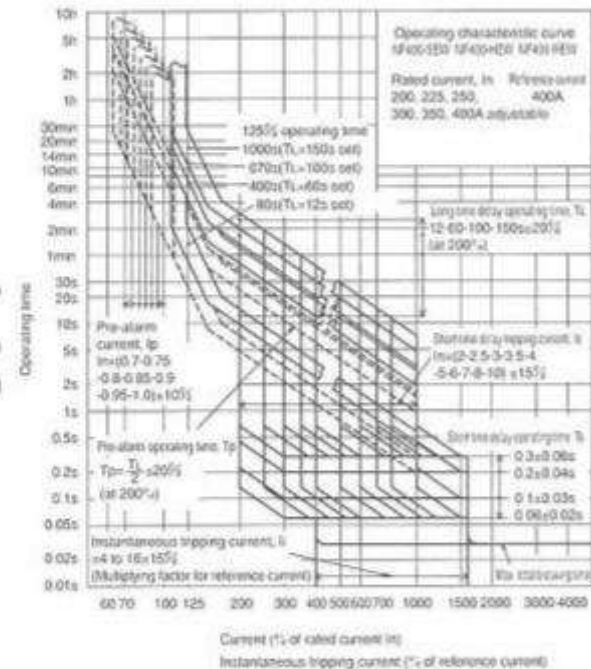

2.2 Earth leakage circuit breaker ELCB structure and operation

Typically the following type of structure is used to detect the ground fault and leakage current with the ELCB. With the TT type earthing system, the ground fault and leakage current are returned to the power source via the ground, so the leakage current is extremely weak small.

The electrical circuit must be grounded (E_B section in figure) to detect the leakage current by ELCB.

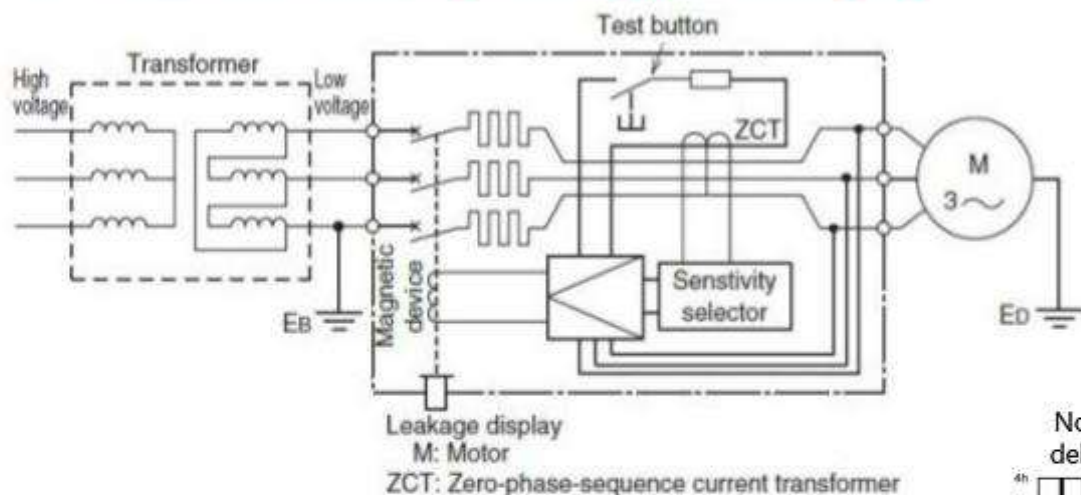

The operating characteristics of the ELCB are expressed as the **earth leakage tripping characteristics** as shown on the right. Typically, it operates with a leakage current that is 50 to 100% of the rated sensitivity current.

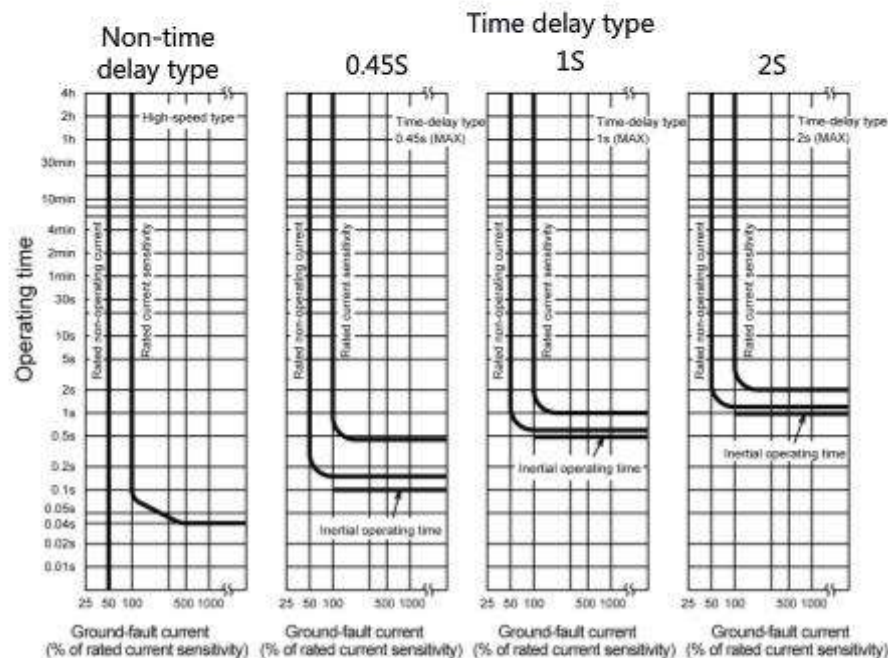

2.2 Measures for unnecessary operation of earth leakage circuit breaker

Advanced and accurate earth leakage protection is made possible with Mitsubishi's original **high-function IC**.

Even with the inverter circuit with digital filter circuit, a part with the sensitivity current as a general circuit can be selected.

A DPDC surge discriminating circuit is incorporated. It is judged as a ground fault and the circuit breaker functions only when the ground fault current polarity alternates with the positive/negative poles for a set time. Thus, the circuit breaker operates accurately without incorrectly tripping at a lightning surge, etc.

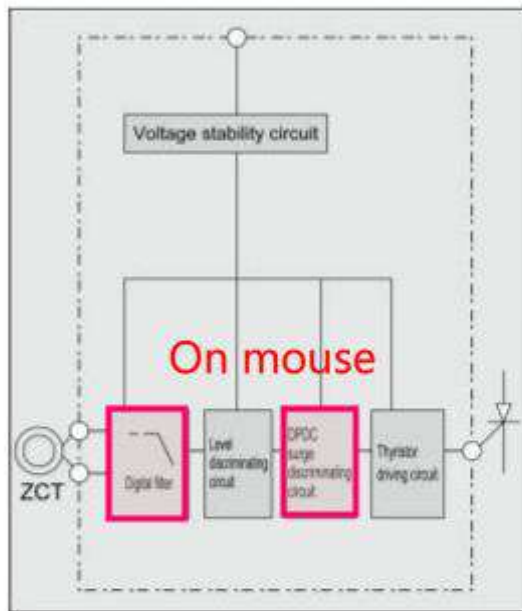

Original IC earth leakage operation block diagram

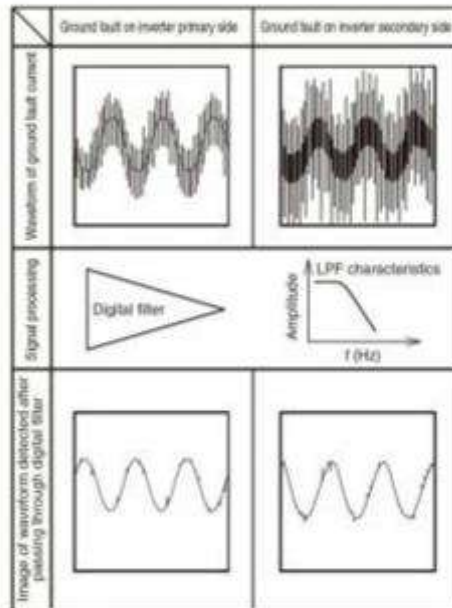

Digital filter circuit operation

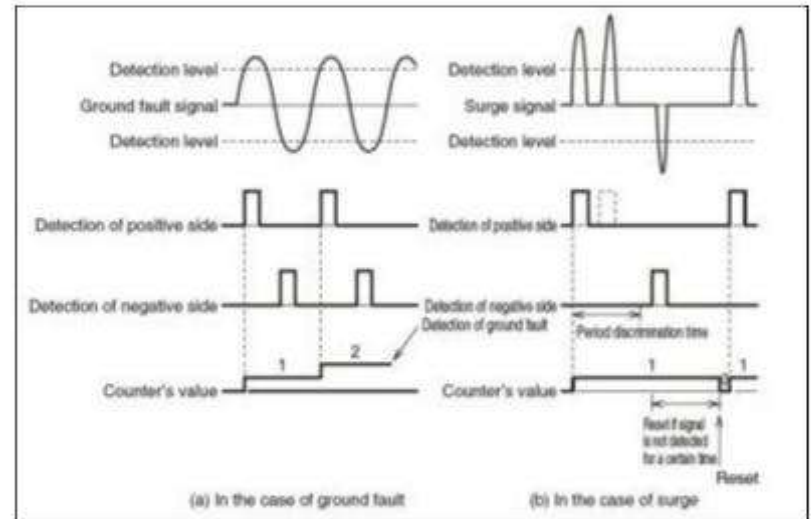

DPDC surge discriminating circuit operation

The types (classes) of ELCBs as specified by IEC 60947-2 are shown below.

The type that is selected is important when considering electric shock protection, earth leakage and fire protection.

If there are applicable laws in the country of use, those must be followed.

Class	Type
Residual current (Rated current sensitivity)	Current sensitivity : fixed type Current sensitivity : adjustable type
Earth leakage operating time	Non time-delay type Time-delay type
Earth leakage detection characteristics	Type AC Type A

The **AC type** corresponds to typical alternating current leakage currents. In an electronic circuit such as an inverter or servo, if the rectifying circuit fails, an earth leakage current with a half-wave rectified waveform or a phase-controlled waveform might be generated. In this case, **A type** earth leakage protection characteristics are needed to detect the half-wave rectified or half-wave phase-controlled earth leakage current waveform.

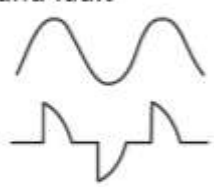
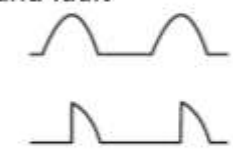
Operating characteristics at ground fault current		
IEC 60947-2 class \ Ground fault waveform	Alternating current ground fault 	Half-wave rectified ground fault 
A type	○ Detectable	○ Detectable
AC type	○ Detectable	× Not detectable

The MCCB is generally classified into the following three types of structural variations according to the connection and mounting method.

- (1) **Front connection type**
- (2) **Rear connection type**
- (3) **Plug-in type**

When further categorized, there are two specifications for the mounted type and two specifications for the connection types. These are used according to the respective characteristics.

		External lead (wire) connection method	
		Front surface terminal screw	Back surface stud
Circuit breaker installation method	Fixed	Front connection type (F)	Rear connection type (B)
	Plug-in type	Double plug-in type for power switchboard (DPM)	Plug-in type (PM)

The front connection types have crimp terminals or bar terminals.

The rear connection type and plug-in type have round studs or bar studs.

Example of rear connection type showing the bar studs

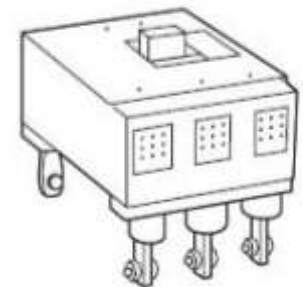

A circuit breaker can be used independently, but its operation can be enhanced by using functional parts called "accessories". These can make easier and more flexible installations.

The "accessories" are largely divided into the internal accessories and external accessories.

Internal accessories are mounted inside the circuit breaker's molded case when used. The main internal accessories are shown below. Mitsubishi Electric use a **cassette type** internal accessory in our 32A to 800A frame models. These **cassette's** can be "mounted in" or "removed from" the circuit breaker by the user.

Auxiliary switch (AX)	Switch to electrically display the ON-OFF status of circuit breaker
Alarm switch (AL)	Switch to electrically display the tripping status of circuit breaker
Shunt trip (SHT)	Device to electrically trip the circuit breaker from a remote location
Under-voltage trip (UVT)	Device to automatically trip the circuit breaker when the control voltage has dropped

Mounting the accessory cassette

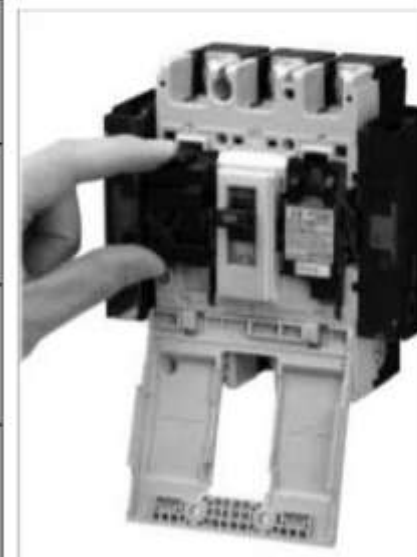

The **external accessories** are mounted onto the outer side of the circuit breaker, and are categorized into the following types.

- (1) Operation-related accessory that assists the functions of the circuit breaker to improve the ease-of-use, to prohibit operations and to provide an interlock
- (2) An Accessory that reinforces the insulation around the terminal and improves the safety

(1) External accessories related to operation

(External) Operating Handles	These handles are used to manually operate the circuit breaker from outside. There are four types used according to the required application. The main types are the F type and V type . The operating handle can be locked in the same manner as the handle locking mechanism.
Electrical Operation Devices	These devices are used to electrically operate the circuit breaker from a remote location. There is a type that converts the motor's rotary movement into a linear movement and directly operate the circuit breaker, and a type that uses the energy stored in a spring.
Handle lock Devices	These devices are used to lock the circuit breaker to the ON or OFF state, and are available as the HL type that is mounted on the circuit breaker's handle and the HL-S type that is fixed onto the cover. Under the IEC Standards, generally only the type that is locked at the OFF position is allowed for safety purposes.
Lock Covers	These covers make it easy to prevent operations without a lock. A "Caution Sign" can also be attached. The term lock is used in the name, but this cover is not approved as a locking mechanism in the Machine Safety Standards.
Mechanical Interlocks	Mechanical interlocks allow one of multiple circuit breakers to be turned ON while preventing the remaining circuit breakers from being turned ON.

Example usage of F type operation handle

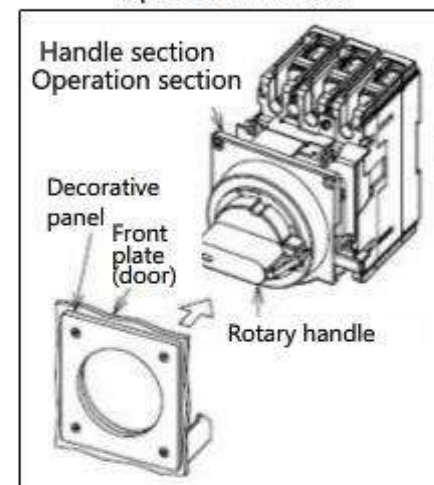

Handle lock device

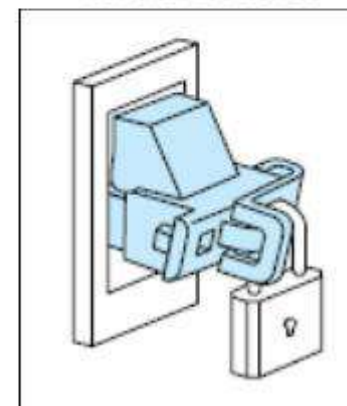

(2) External accessories used around terminal

Terminal Covers	This covers the exposed sections of the terminal used to connect the external leads such as wires to the circuit breaker. Various types of covers are available such as the large terminal cover that can cover the crimp terminal (TC-L), the small terminal cover that covers only the terminal section (TC-S), the transparent terminal cover through which the connections can be seen (TTC), and the terminal cover that covers the stud connections on the rear connection type or plug-in type (BTC) (PTC), etc.
Insulating Barriers	This barrier strengthens the insulation between the phases on the circuit breaker's terminals, and can prevent accidents from conductive foreign matter or dust.

Large terminal cover

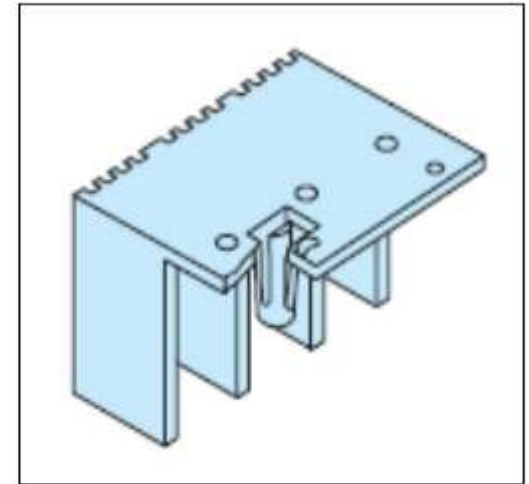

The following items related to circuit breakers and ELCBs were studied in this chapter.

- The circuit breaker is used for **overload and short-circuit protection** of an electrical circuit's wiring and bus-bars. The ELCB also provides **electric shock protection and protection against fires caused by earth leakages**.
- The circuit breaker is configured of a switching mechanism that opens and closes the contact, a tripping mechanism that reacts to the overcurrent and trips the switching mechanism, and an arc extinguishing device that breaks the fault current.
- When using the ELCB, **a suitable detection method for the load** must be selected.
- The circuit breaker has **various accessories** that make it easier and more flexible to use.

The methods of selecting circuit breaker and information on protective coordination are covered in the next chapter.

Please take the review test for this chapter to confirm your understanding.

We will continue to study the selection of the circuit breaker and protective coordination in the next chapter.

Fill in the blank with the term that is most appropriate.

The motor circuit requires several functions, but a typical molded-case circuit breaker does not perform the (a) function.

a)

Answer

Back

Correct answer - please continue or press "y" to click on the screen.

Fill in the blanks with the term that is most appropriate.

The electrical circuit must be (a) for the ELCB to function in the event of a ground fault or leakage current accident.

a) grounded ▼

Answer

Back

Correct answer - please
continue or press "y" to
click on the screen.

Fill in the blanks with the term that is most appropriate.

The Mitsubishi ELCB uses (a) as a measure against nuisance trip in the event of a surge.

a) a digital filter and DPDC surge discriminating circuit ▼

Answer

Back

Correct answer - please
continue or press "y" to
click on the screen.

This chapter covers how to select a low-voltage circuit breaker or ELCB, and information about protective coordination.

Chapter 3 Study Content

- 3.1 Selecting procedures
- 3.2 Selecting the rated voltage
- 3.3 Approved standards
- 3.4 Determining the rated current
- 3.5 Determining the rated breaking capacity
- 3.6 Determining the rated current sensitivity
- 3.7 Summary of chapter

The selection process refers to determining the actual required model while reviewing **the applicable standards, rated current, breaking capacity and protective coordination between the circuit breakers.**

MCCB selecting procedures

Applicable standard	Wire system, voltage, DC or AC, frequency, standard	<ul style="list-style-type: none"> •Earthing system TN-S, TN-C, TN-C-S, TT, IT •Certified approval
Determination of rated current	Size of connecting wires Usage Law and regulation	<ul style="list-style-type: none"> •Consider temperature and connecting wire size •Selection of MCCB for motor branch circuit •Selection of MCCB for lamp or heater circuit •Selection of MCCB for motor protection •Selection of MCCB for inverter circuit •Selection of MCCB for transformer primary side
Determination of breaking capacity	Transformer capacity Impedance of the electrical circuit	<ul style="list-style-type: none"> •Selection of breaking capacity •Consideration for cascade breaking
Coordination	Selective coordination	<ul style="list-style-type: none"> •Operating characteristic curve •Consideration of selective coordination
Installation method	Type of connection	• Installation and connection
Accessories	Internal and external accessories Electric operation	<ul style="list-style-type: none"> •Internal accessories •External accessories •Motor drive for MCCB

ELCB selecting procedures

Applicable standard	Wire system, voltage, standard	<ul style="list-style-type: none"> •Earthing system TN-S, TN-C, TN-C-S, TT, IT •Certified approval
Determination of rated current	Size of connecting wires Usage Law and regulation	<ul style="list-style-type: none"> •Consider temperature and connecting wire size •Selection of ELCB for motor branch circuit •Selection of ELCB for lamp or heater circuit •Selection of ELCB for motor protection •Selection of ELCB for inverter circuit •Selection of ELCB for transformer primary side
Determination of breaking capacity	Transformer capacity Impedance of the electrical circuit	<ul style="list-style-type: none"> •Selection of breaking capacity •Consideration for cascade breaking
Determination of rated current sensitivity	Purpose of protection Law and regulation	<ul style="list-style-type: none"> •Purpose of protection •Selection of ELCB rated current sensitivity
Coordination	Selective coordination	<ul style="list-style-type: none"> •Operating characteristic curve •Consideration of selective coordination •Earth leakage protective coordination
Installation method	Type of connection	•Installation and connection
Accessories	Internal and external accessories Electric operation	<ul style="list-style-type: none"> •Internal accessories •External accessories •Motor drive for ELCB

The following three ratings are specified as the "rated voltage" in the IEC Standards.

- (1) **Ui: Rated insulation voltage**
- (2) **Ue: Rated operational voltage**
- (3) **Uimp: Rated impulse withstand voltage**

Basically the rated operational voltage is required to actually use the circuit breaker.

The selection of the circuit breaker's rated voltage (rated operational voltage) differs between the circuit breaker MCCB and the earth leakage circuit breaker ELCB.

- With an MCCB, a higher operational voltage can contain a lower voltage.
However, the rated breaking capacity will not increase even if the voltage is low.
- With an ELCB, the earth leakage tripping device relies on the operational voltage, so it must be used **within the voltage fluctuation range in which the leakage protection function is operable** as shown on the right.

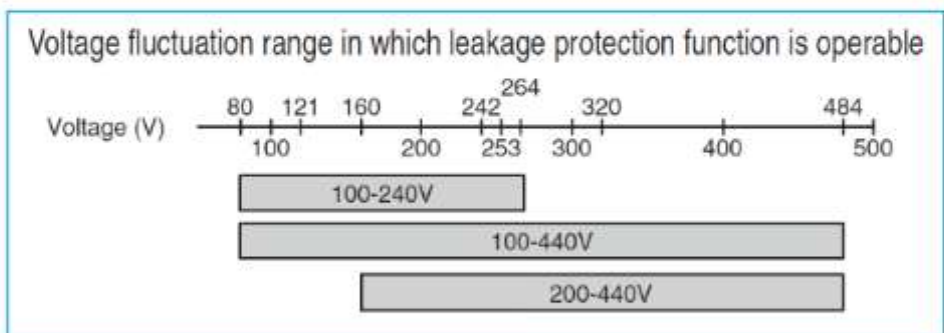

An approval mark, as indicated on the circuit breaker, identifies that it complies with that standard or regulations. The approval status of the Mitsubishi Electric's circuit breaker's can be confirmed at the following URL. A certificate can be downloaded from this site. <http://www.mitsubishielectric.co.jp/haisei/lvs/downloads/certifications.htm>
An example of the approval status for the Air Circuit Breaker is shown below.

Type	China compulsory	CE marking	Shipping approval						Certificate by testing authority	
	CCC	CE	LR	GL	BV	DNV	ABS	CCS	ASTA	KEMA
AE630-SW	○	○	○	○	○	○	○	○	-	-
AE1000-SW	○	○	○	○	○	○	○	○	○	-
AE1250-SW	○	○	○	○	○	○	○	○	○	-
AE1600-SW	○	○	○	○	○	○	○	○	○	-
AE2000-SWA	○	○	○	○	○	○	○	○	-	-
AE2000-SW	○	○	○	○	○	○	○	○	○	-
AE2500-SW	○	○	○	○	○	○	○	○	○	-
AE3200-SW	○	○	○	○	○	○	○	○	○	-
AE4000-SWA	○	○	○	○	○	○	○	○	○	-
AE4000-SW	○	○	○	○	○	-	○	-	-	○
AE5000-SW	○	○	○	○	○	-	○	-	-	○
AE6300-SW	○	○	○	○	○	-	○	-	-	○

3.4 Determining the rated current

When studying protective coordination, **it must be considered in terms of operational aspects and non-operational aspects.**

The method of considering the protective coordination with its characteristics is explained below using a motor circuit as an example.

Operational aspects

- Some of the MCCB operating characteristics crossover with the motor's thermal characteristics, so the motor's thermal protection is compromised. [On mouse](#)
- The THR operating characteristics are at the left side of the motor's thermal characteristics, so there are no sections that cross over. Thus, the motor's thermal protection is unaffected.
- The MCCB operating characteristics cross over on the left side of the THR blowout point, so THR blowout protection is possible. [On mouse](#)

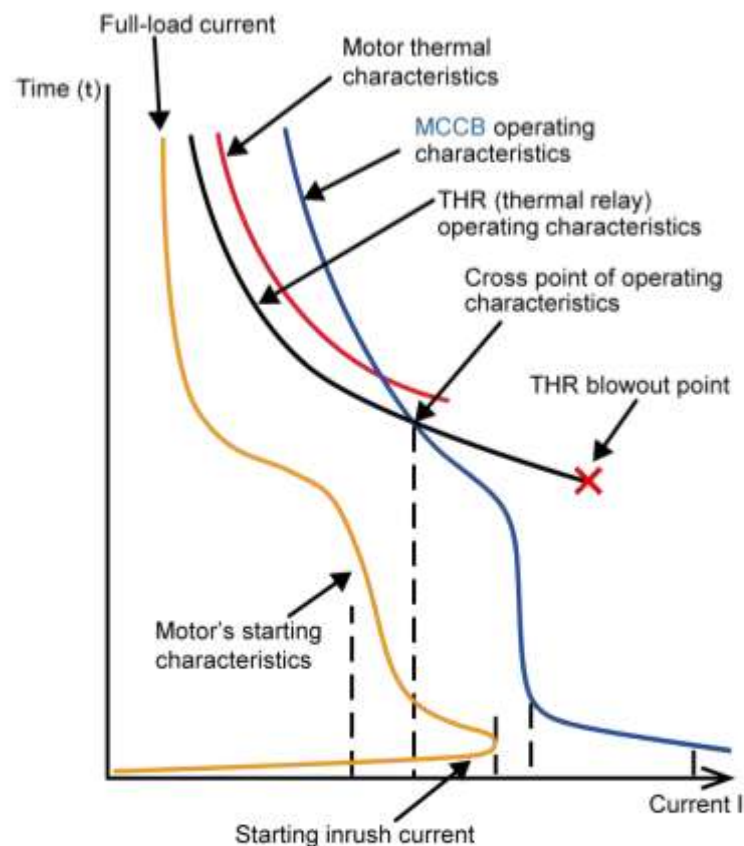
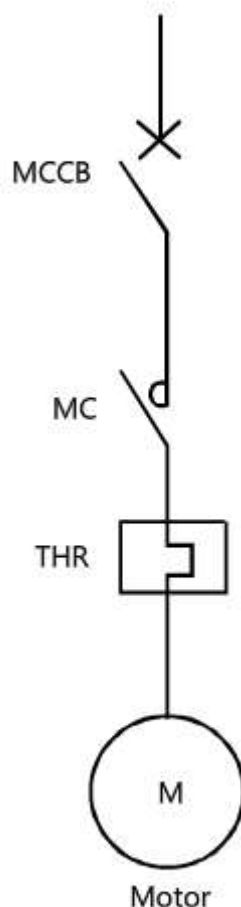

Non-operational aspects

- The motor's starting characteristics (starting inrush current or starting current) is at the left side of the MCCB's operating characteristics, so the motor's starting characteristics will not cause the MCCB to nuisance trip. On mouse

- The motor's full-load current is at the left side of the THR rated current or MCCB's rated current so the motor's full-load current will not cause the THR or MCCB to nuisance trip. On mouse

When protective coordination is considered from both the operational aspect and non-operation aspect as shown above, the results show that there are no problems. Protective coordination is established with the load and the MCCB's rated current has been properly selected.

Coordination with the wires is not covered here, but the protective coordination for the MCCB's operating characteristics and wire's thermal characteristics must be considered in the same manner.

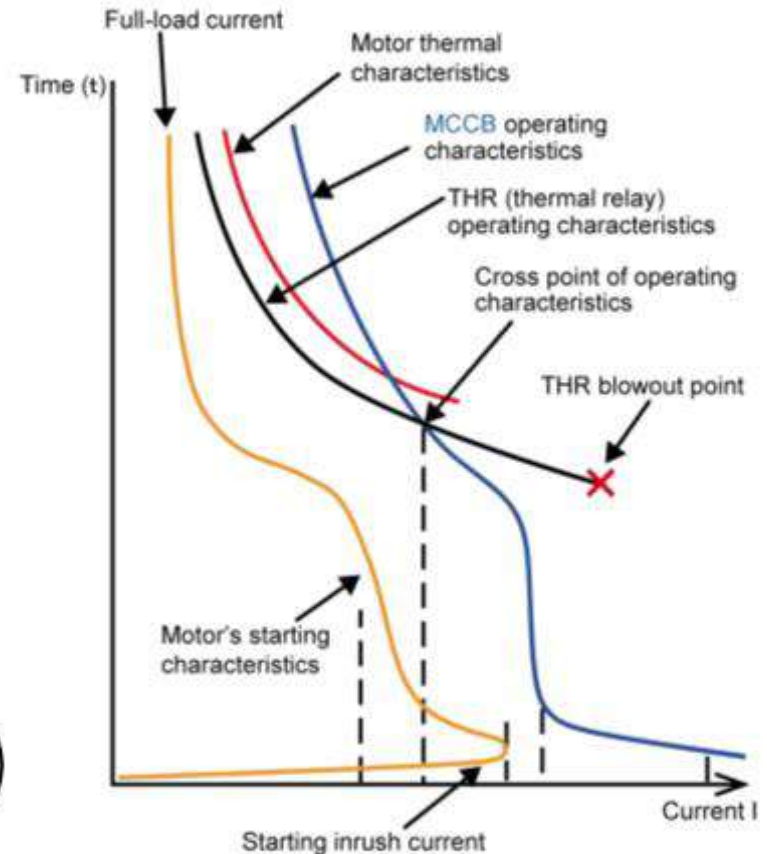
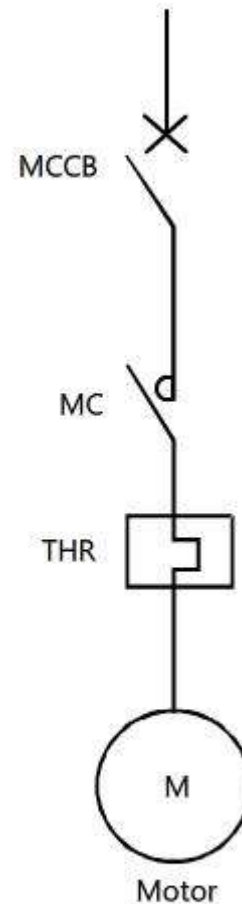

The following ratings are specified in the IEC Standards as the "rated breaking capacity".

- (1) **Icu: Ultimate short circuit breaking capacity**
- (2) **Ics: Service short circuit breaking capacity**

Check the rated breaking capacity indicated in the product catalog's specification tables (shown on the right) or as indicated on the product's nameplate. Select a breaker with a value larger than the fault current (estimated short-circuit current) that could flow to the place where the breaker is installed.

Normally, **short-circuit protection can be established by using the Icu value.**

$I_{cu} \geq$ Estimated short-circuit current

Specification table from Mitsubishi Electric's product catalog (example)

Frame (A)		50			60			63				
Model		NF63-SV										
Image												
Rated current In (A)		3 4 (5) 6 10 (15) 16			(60)			63				
Rated ambient temperature 40°C (45°C for marine use)		20 25 (30) 32 40 50										
Number of poles		2 3 4			2 3 4			2 3 4				
Rated insulation voltage U _i (V)		600										
Rated short-circuit breaking capacity (kA)	IEC 60947-2 EN 60947-2 (Icu/Ics)	AC	690V	-			-			-		
			500V	7.5/7.5			7.5/7.5			7.5/7.5		
			440V	7.5/7.5			7.5/7.5			7.5/7.5		
			415V	7.5/7.5			7.5/7.5			7.5/7.5		
			400V	7.5/7.5			7.5/7.5			7.5/7.5		
			380V	7.5/7.5			7.5/7.5			7.5/7.5		
			230V	15/15			15/15			15/15		
200V	15/15			15/15			15/15					
DC	250V	7.5/7.5 (*5)			7.5/7.5 (*5)			7.5/7.5 (*5)				
Rated impulse withstand voltage U _{imp} (kV)		8			8			8				
Current (*1)		AC/DC compatible			AC/DC compatible			AC/DC compatible				
Suitability for isolation		Compatible			Compatible			Compatible				
Reverse connection		Possible			Possible			Possible				
Number of operating cycles	Without current	10,000			15,000			15,000				
	With current (440VAC)	6,000			8,000			8,000				
Utilization category		A			A			A				
Pollution degree		3			3			3				
EMC environment condition (environment A or B)		N/A			N/A			N/A				
Overall dimensions (mm)		a	50	75	100	50	75	100	50	75	100	
		b	130			130			130			
		c	68			68			68			
		ca	90			90			90			
		Mass of front-face type (kg)	0.5	0.7	0.9	0.55	0.75	1.0	0.55	0.75	1.0	
Installation and connectors	Front connection (F)	●Screw terminal			●Screw terminal			●Screw terminal				
	Solderless (BOX) terminal (SL)	-			-			-				
	Rear (B)	●Round stud			●Round stud			●Round stud				
	Plug-in (PM)	●			●			●				
Cassette-type accessories	Alarm switch (AL)	● (*4)			● (*4)			● (*4)				
	Auxiliary switch (AX)	● (*4)			● (*4)			● (*4)				
	Shunt trip (SHT)	● (*4)			● (*4)			● (*4)				
	Undervoltage trip (UVT)	● (*4)			● (*4)			● (*4)				
	With lead-wire terminal block (SLT)	●			●			●				
	Pre-alarm (PAL)	-			-			-				

The ELCB has a unique rating called the **"rated current sensitivity"**. This section explains how to select this rated current sensitivity.

There are various theories about the physiological phenomena that occur when a current passes through the human body. If the safety standards are set based on the IEC/TS60479-1 curve, the followings can be considered.

Safe area

- Place where secondary disaster could occur due to electrical shock: Area below curve b
- Place where there is no risk of secondary disaster from electrical shock: Area below curve c1

The rated current sensitivity for the ELCB must be selected according to these two zones.

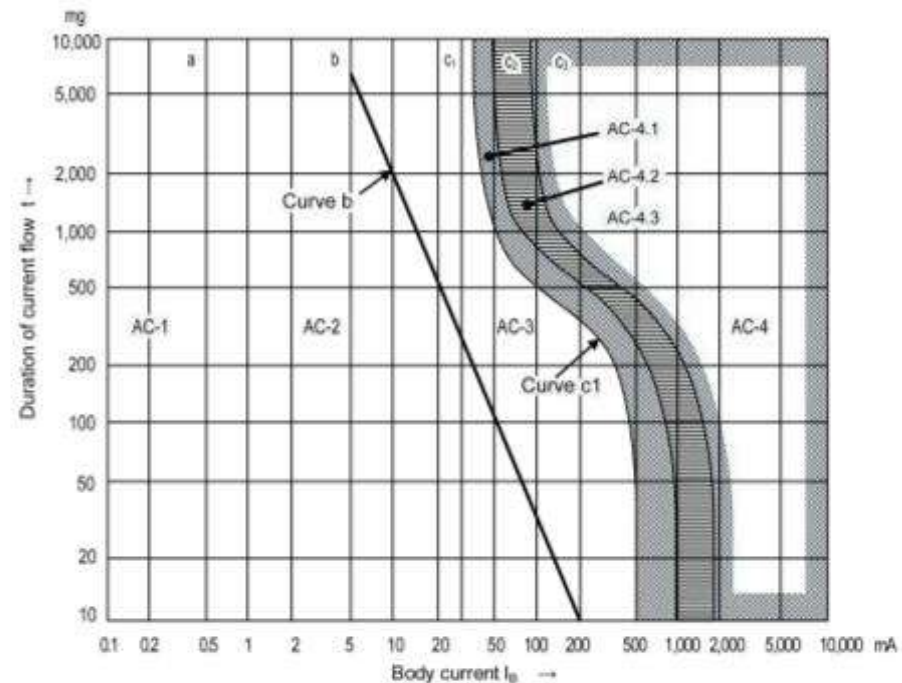

Zones	Boundaries	Physiological effects
AC-1	Up to 0.5 mA curve a	Perception possible but usually no 'startled' reaction
AC-2	0.5 mA up to curve b	Perception and involuntary muscular contractions likely but usually no harmful electrical physiological effects
AC-3	Curve b and above	Strong involuntary muscular contractions. Difficulty in breathing. Reversible disturbances of heart function. Immobilization may occur. Effects increasing with current magnitude. Usually no organic damage to be expected.
AC-4	Above curve c1	Patho-physiological effects may occur such as cardiac arrest, breathing arrest, and burns or other cellular damage. Probability of ventricular fibrillation increasing with current magnitude and time.
AC-4.1	c1-c2	AC-4.1 Probability of ventricular fibrillation increasing up to about 5%
AC-4.2	c2-c3	AC-4.2 Probability of ventricular fibrillation up to about 50%
AC-4.3	Beyond curve c3	AC-4.3 Probability of ventricular fibrillation above 50%

The rated current sensitivity of the ELCB also equates to the level of protection against electric shocks or earth leakage fires. However, it is also important to consider nuisance operations.

The area between the wire and ground can be artificially connected through a capacitor. In the electrical facilities in AC circuit, even if the electrical circuit insulation resistance is normal, some leakage current constantly flows through the **floating capacitance** between the wire and the ground.

This is called the **constant leakage current**, and can be approximately calculated if the type of wire, size of wire and the length of the electrical circuit from the ELCB installation point to the load device, etc., are known. It is important **to set the rated current sensitivity so that the ELCB does not operate unnecessarily by this constant leakage current.**

Typically, the rated current sensitivity can be obtained with the following formula.

$$\text{Rated current sensitivity } +I_{\Delta n} \geq 10 \times (I_{gl} + I_{gm})$$

Where, I_{gl} : Leakage current from wire(mA), I_{gm} : Leakage current from motor(mA),

10: Constant for transient inrush current

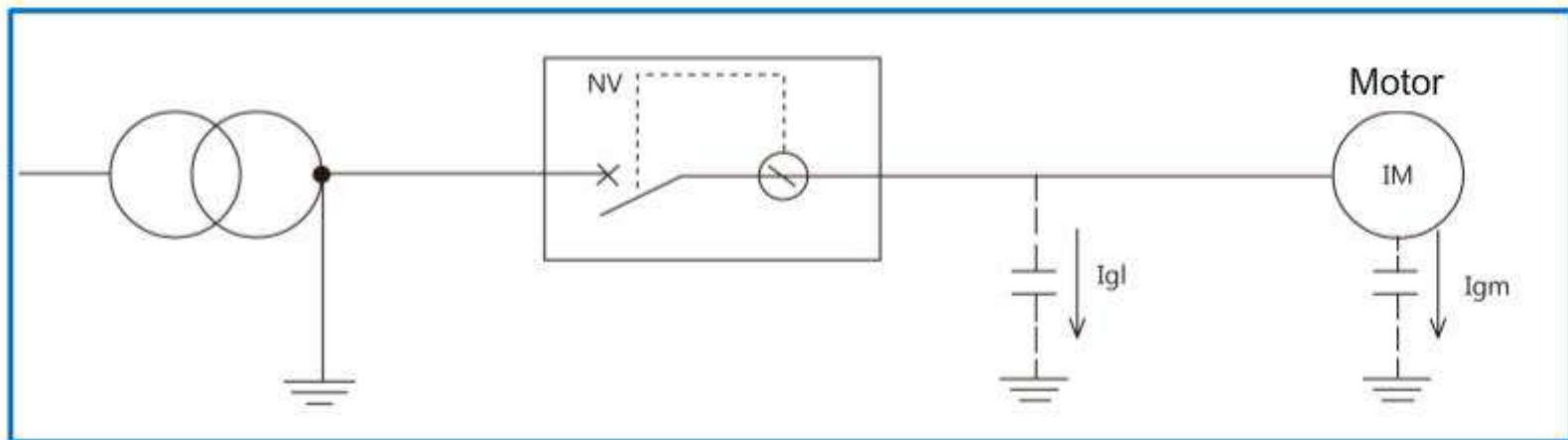

In this chapter, circuit breaker selection theory was studied, and the following points regarding selection were covered.

- For the rated voltage of the ELCB, the earth leakage protection function must apply **within the operable voltage fluctuation range**.
- The rated current is determined using the operation characteristics curve while considering the protective coordination for both the **operational and non-operational aspects**.
- **A circuit breaker where the ultimate short -circuit breaking capacity(Icu)** is larger than the short-circuit fault current to the installation place **must be selected**.
- The rated current sensitivity must be **10 times or higher** than the **constant leakage current**.

The next chapter covers the life of the circuit breaker and when to upgrade the circuit breaker.

Please take the review test for this chapter to confirm your understanding.

We will continue to study the life of the circuit breaker and update/upgrade processes in the next chapter.

Fill in the blanks with the term that is most appropriate.

Ultimate rated short circuit breaking capacity I_{cu} of the circuit breaker as a rule must have a value larger than (a) at the place where the circuit breaker is installed.

a)

Answer

Back

Correct answer - please
continue or press "y" to
click on the screen.

Fill in the blanks with the term that is most appropriate.

The rated current sensitivity of the selected ELCB should be 10 times larger than the (a).

a)

Answer

Back

Correct answer - please
continue or press "y" to
click on the screen.

This chapter covers the basic information regarding the circuit breaker service life and renewal.

Chapter 4 Study Content

4.1 What is the service life of a circuit breaker?

4.2 Renewal diagnosis of the circuit breaker

4.3 The circuit breaker renewal

4.4 Summary of chapter

The circuit breaker has reached the end of its service life when a decline starts in one of the basic function's.

There may be cases when the device looks normal but has actually reached the end of its service life.

The basic functions include:

- (1) Withstanding of the operational voltage
- (2) Carry load current
- (3) Switching(ON/OFF operation)
- (4) Trip with overload
- (5) Operate with a leakage current (ELCB)
- (6) Operate when test button is pressed (ELCB)

When the basic functional decline starts, there is a risk that various malfunction's may occur. There is also a risk Of a secondary accident resulting from these faults.

- | | |
|---|---|
| (1) Insulation failure | -> Risk of burning, internal short-circuit and electric shock, etc. |
| (2) Defective continuity | -> Risk of burning from internal overheating or nuisance operation, etc. |
| (3) Operational malfunction | -> Risk of an uncontrolled electrical circuit |
| (4) Defect in the operating characteristics | -> Risk of wire burning |

An insulation failure resulting from age deterioration is shown below as an example of an accident caused by a circuit breaker reaching the end of its service life.

The following circuit breaker was in service for more than 25 years:

- (1) Thermal mechanical stress was applied on the cross bar section* for a long time,
- (2) This caused the insulation at the cross bar to markedly degrade, and
- (3) Ultimately, the insulation broke down and an inter-phase short-circuit occurred.

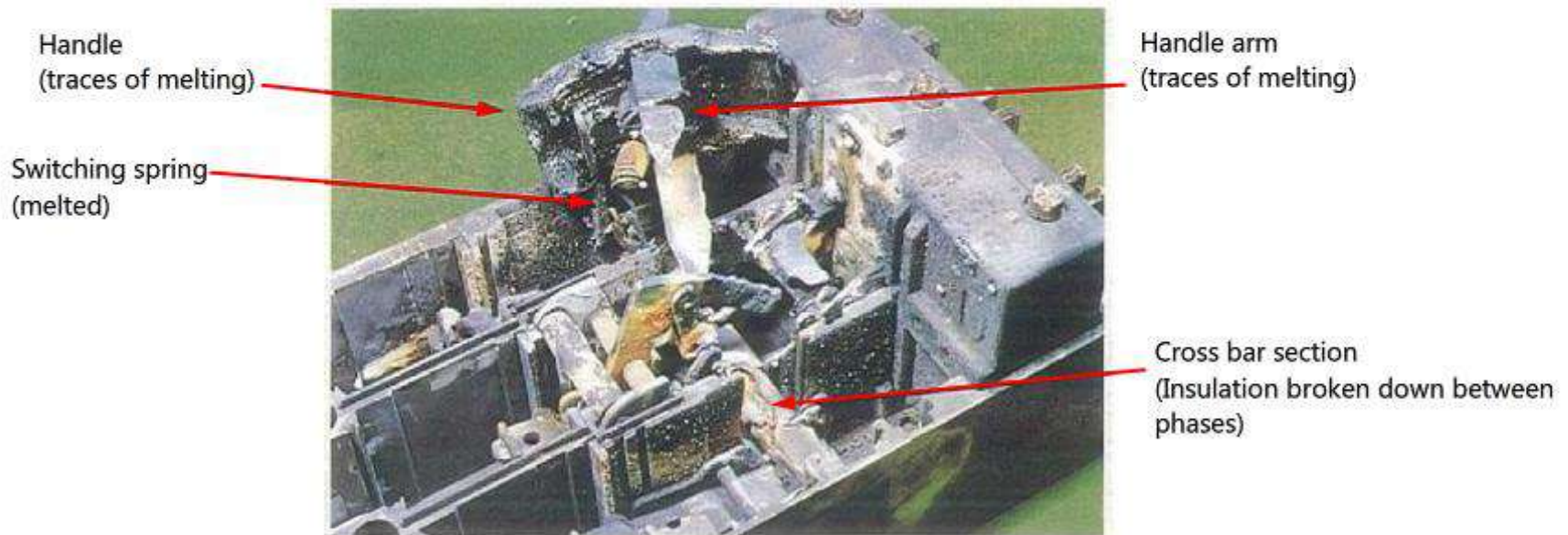

* The cross bar is a shaft made of insulating material and is set across poles to simultaneously switch the poles of a 3-pole circuit breaker, etc.

Daily inspections are important **preventive maintenance**.

Pay attention to heating, abnormal odors, abnormal sounds, discoloration, dust and metal chips, etc., when performing an inspection. Check for heating by measuring the surface of the circuit breaker's molded case with an infrared thermometer, or by using a thermo-label, etc.

MCCB temperature rise reference values (example)

These are examples for a new product, and are not guaranteed values.

Model	Conducting current	Measurement point				
		Cover surface (A)	Base side (B)	Handle (C)	Line terminal	Load terminal
NF32-SV	32A	14	38	12	36	37
NF63-CV	63A	15	42	14	39	44
NF63-SV	63A	15	39	12	41	44
NF63-HV	63A	15	42	12	41	49
NF125-CV	125A	13	29	9	43	42
NF125-SV	125A	14	32	10	44	40
NF125-HV	125A	16	33	11	49	42
NF250-CV	250A	19	35	13	46	45
NF250-SV	250A	20	36	13	47	45
NF250-HV	250A	20	36	13	49	46
NF30-CS	30A	18	15	5	23	33
NF125-SGV	125A	20	35	13	42	49
NF250-SGV	250A	20	36	13	49	50
NF160-SGV	160A	20	35	13	40	44

Temp. °C	State when touched
40	Somewhat hot
50	Quite hot
60	Rather hot
70	Very hot
80	Very hot

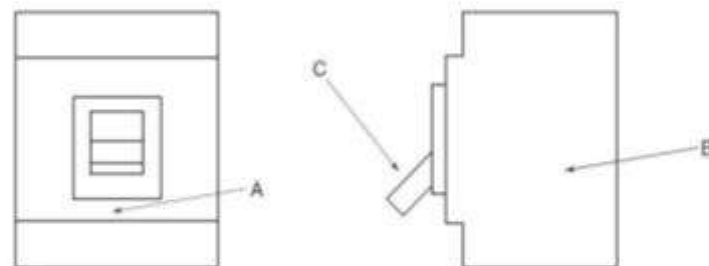

The temperature rise values are shown on the left. With the actual temperature measurement, the ambient temperature is also measured.

For example, when the NF125-SV is energized with 125A and the ambient temperature is 40 °C, the molded case's surface temperature at B will be:

$$40\text{ °C (ambient temp.)} + 32\text{K (temp. rise value)} = 72\text{ °C}$$

The value will differ according to the actual wire size and the circuit breaker installation conditions. If the value greatly exceeds the values in the table, it may be necessary to consider the current derating, performing a wire check or reconsider the heat ventilation method.

Mitsubishi Electric guides for the working environment and life are shown below.
The working environment greatly affects the low-voltage circuit breaker's performance and life.

Degree	Environment	Actual example	Guide for replacement (years)
Good environment	Place where air is always clean and dry	Electricity room with dust-proof and air-conditioning, etc.	Approx. 10 to 20
	Indoors where levels of dust, etc., are low and there is no corrosive gas	Independent electricity room's power distribution panel with no dust-proofing or air-conditioning, and breakers installed in enclosure	Approx. 7 to 15
Poor environment	Place with gases containing sulfurous acid, hydrogen sulfide, salt or high levels of moisture, etc., but with low levels of dust	Geothermal power plant, sewage treatment plant, iron and steel mill, paper mill, pulp plant, etc.	Approx. 3 to 7
	Place with particularly high levels of corrosive gases and dust, where humans cannot stay for long periods of time	Chemical plants, quarries, mines, etc.	Approx. 1 to 3

The following items related to the renewal of the circuit breakers and ELCBs were studied in this chapter.

- The circuit breaker **reaches its life when these is a start in the decline of one of the basic function's**
- Discovering heating, abnormal odors, abnormal noise, discoloration and accumulation of dust and metal chips, etc., during daily inspections is an important part of **preventive maintenance**.
- **The renewal policy of a breaker varies according to the working environment.**

This completes the four chapters. Please take the review test for this chapter to confirm your understanding.

Fill in the blanks with the term that is most appropriate.

A decline in the circuit breaker's (a) is interpreted as the end of life. It is important for the risk assessment of the electrical facility to renew the breaker as soon as possible.

a)

Answer

Back

Correct answer - please
continue or press "y" to
click on the screen.

Fill in the blanks with the term that is most appropriate.

The working environment greatly affects the low-voltage circuit breaker performance and service life. The reference life of Mitsubishi Electric's low-voltage circuit breaker used indoors with low levels of dust and free of corrosive gases is (a) years.

a)

Answer

Back

Correct answer - please continue or press "y" to click on the screen.

You have completed the Low-Voltage Circuit Breakers Basic Course.

Thank you for taking this course.

We hope you enjoyed the lessons and the information you acquired in this course will be useful in the future.

You can review the course as many times as you want.

Review

Close

**Thank you very much for joining the Mitsubishi Electric LVS e-learning.
The course is now finished.**

**Mitsubishi Electric-Forever Pioneering the Future of Circuit Breakers.
Mitsubishi low voltage circuit breakers protect the base of the social life.**

