



FA Equipment for Beginners (Inverters)

This is a quick overview of Inverters for beginners.

Introduction

Purpose of the Course

This is an introductory course designed to provide beginners, who are new to Inverters, an opportunity to learn the basics of Inverters.

Introduction **Course Structure**

Chapters of this course are made up as follows.
We recommend that you start from Chapter 1.

Chapter 1 - What are Inverters?

Learn about the basics of Inverters including: role, practical applications, structures, advantages.

Final Test

Passing grade: 60% or higher.

Introduction **How to use this e-Learning Tool**

Go to the next page		Go to the next page.
Back to the previous page		Back to the previous page.
Move to the desired page		"Table of Contents" will be displayed, enabling you to navigate to the desired page.
Exit the learning		Exit the learning. Window such as "Contents" screen and the learning will be closed.

>> **Introduction** **Precautions for Use**

Safety Precautions

Before using the physical hardware, please read the Safety Precautions in the corresponding manuals and follow the relevant safety information contained therein.

Chapter 1 What is an Inverter?

1.1 The Role of an Inverter

There have been more and more consumer electronics products in recent years that use "inverter" in their name. For example, most air conditioners nowadays are "inverter air conditioners".

Air conditioners work to adjust temperature by using the power from a motor to circulate a refrigerant.

However, an air conditioner may not be deemed very useful if, for example, the only two settings available are to run it at full power or turn it off completely.

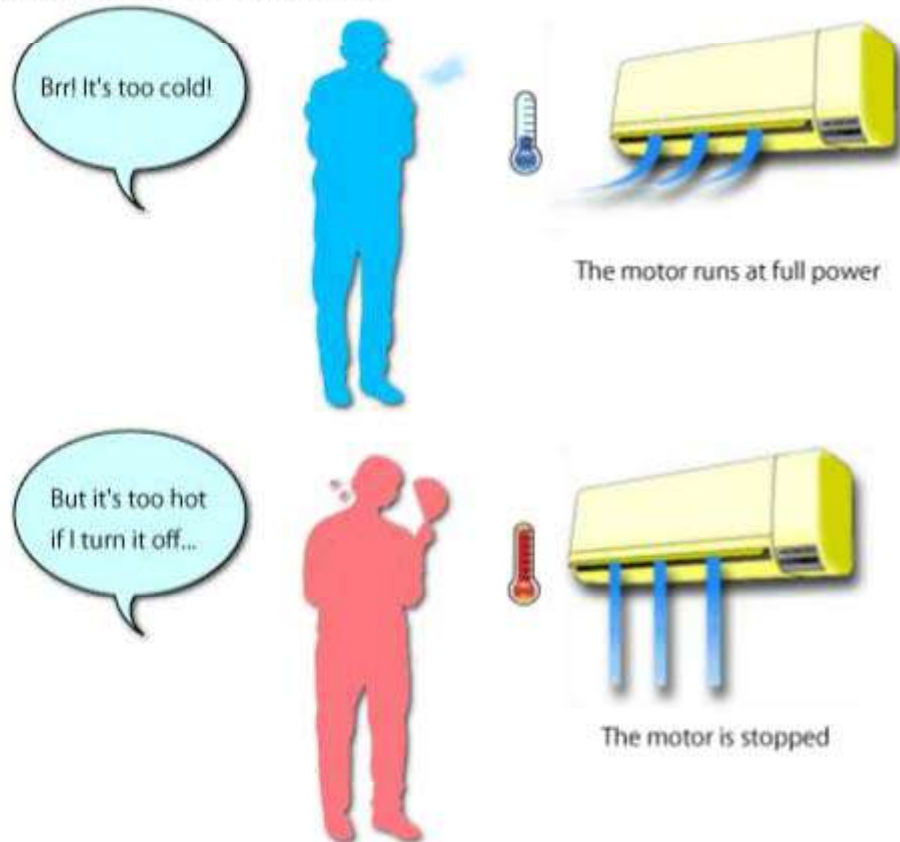

1.1**The Role of an Inverter**

You can set an air conditioner to a desired temperature if you're able to flexibly control how fast the motor rotates.

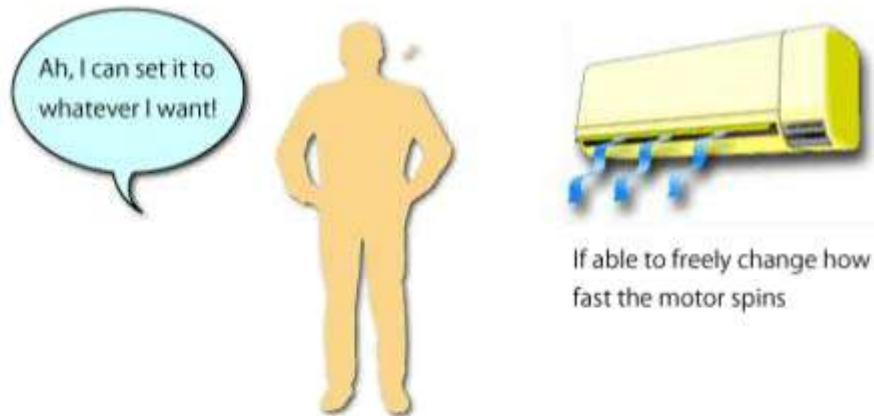

In short, an inverter used in this kind of situation is a device that allows you to freely and continuously as well as efficiently change the rotational speed of a motor.

1.1

The Role of an Inverter



For industrial-use inverters, the type of motor commonly used is a three-phase squirrel-cage (induction) motor. (Below, this type of motor will be referred to as a 3-phase motor or simply motor in order to simplify things.)

[Overview of Inverters]

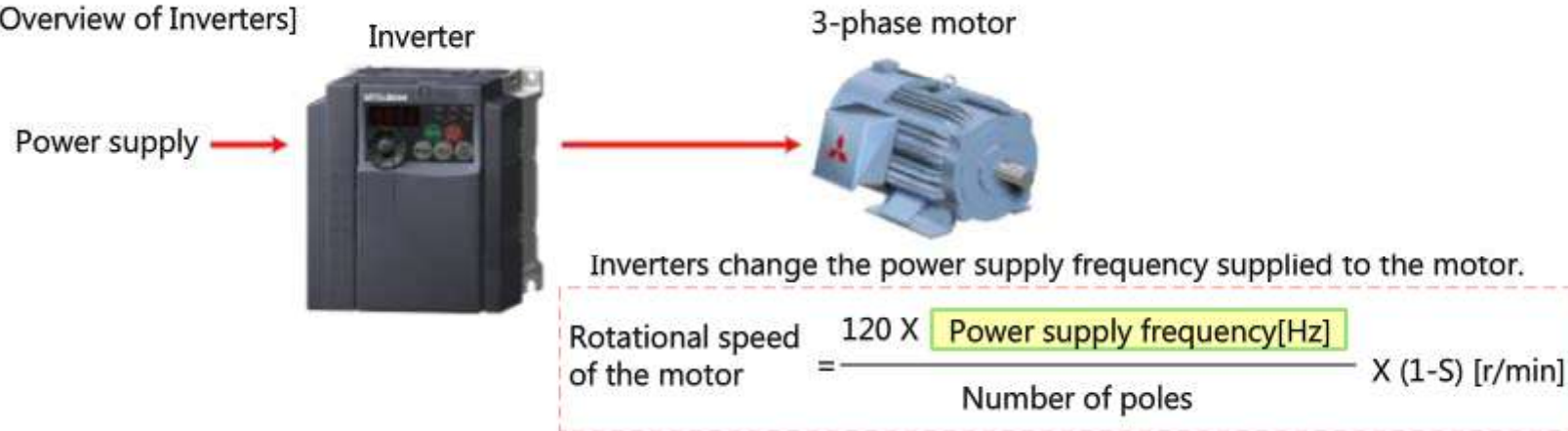

Synchronous rotational speed (N_0)	$N_0 = (120 \times \text{Power supply frequency}) / \text{Number of poles}$
Number of poles	Determined by the motor configuration. Ex.) 4P is used to indicate a 4-pole motor.
Slip (S)	During rated operation, S is usually around 0.03 to 0.05. When the motor is stopped, S is equivalent to 1.

The rotational speed of a motor is usually determined by the power supply frequency transmitted to the motor itself and the number of poles that the motor has.

The number of poles that a motor has cannot be changed flexibly or continuously.

On the other hand, even though the power supply frequency supplied by a utility company is fixed (at either 50 Hz or 60 Hz for Japan), you should still be able to freely change the rotational speed of the motor if you can devise a way to freely adjust the frequency transmitted to the motor.

An inverter is a device constructed with this goal in mind of being able to freely adjust the frequency.

1.1**The Role of an Inverter**

[Basic Characteristics of a (Squirrel-Cage Induction) Motor]

Knowing the characteristics of the (squirrel-cage induction) motor that you need to control is extremely important for being able to utilize an inverter properly.

We have included an overview of the basic characteristics of inverters below to help you better understand what inverters do.

(1) Rotational speed--Torque/Current characteristics

The basic characteristics of a (squirrel-cage induction) motor include rotational speed-output torque characteristics and rotational speed-current characteristics.

The motor torque and current change as shown in the diagram below after the power supply is turned on through when the motor is started up → accelerated → reaches a certain speed.

The current is highest when the motor is started up and begins to decrease as the rotational speed increases. The torque increases as the rotational speed increases but begins to drop once the rotational speed has exceeded a certain value.

Normal-speed operation begins at the point where the load torque and torque generated by the motor are the same.

1.1

The Role of an Inverter



(2) Rotational speed of the motor

The rotational speed of the motor is determined not only by the load torque but also by the number of poles in the motor and the power supply frequency applied.

Putting this into an equation form yields the expression shown below.

$$\text{Rotational speed of the motor} = \frac{120 \times \text{Frequency } f \text{ [Hz]}}{\text{Number of poles}} \times (1-S) \text{ [r/min]}$$

→ Synchronous rotational speed
→ Slip

(3) Rated motor torque

Torque is defined to be a measure of the force generated that causes the motor to turn.

The standard unit for force for linear motion is the newton, with symbol N. However, as a motor rotates about an axis, the force generated is not from a linear motion but from a rotational motion, the torque, which is expressed in units of newton-meters, N·m.

The rated motor torque can be calculated using the formula shown below.

$$\text{Rated torque } T_m = 9550 \times \frac{\text{Rated motor output } P \text{ [kW]}}{\text{Rated rotational speed } N \text{ [r/min]}} \text{ [N}\cdot\text{m]}$$

1.1**The Role of an Inverter****(4) Slip**

When a load is applied, the rotational speed of the motor becomes shifted from (drops to be lower than) the synchronous rotational speed.

Slip refers to the amount of shift in the rotational speed of the motor from the synchronous rotational speed.

$$\text{Slip } S = \frac{\text{Synchronous rotational frequency } N_0 - \text{Rotational speed } N}{\text{Synchronous rotational speed } N_0} \times 100 [\%]$$

- The slip is at 100% at startup (when the rotational speed is 0). (Slip is normally expressed as Slip 1.)
The slip is at several percent as the frequency is slowly increased with the inverter (which also refers to the startup frequency).
- The slip is usually at around 3% to 5% while the motor is operating at normal torque.
The slip increases as the load torque increases (overload), causing the motor current to also increase.
- The slip becomes negative when the rotational speed exceeds the synchronous rotational speed ($N > N_0$).

1.2 Practical Applications of Inverters

Inverters are also used in common electronic appliances and other equipment such as consumer air conditioners. Here, we shall present examples of inverters used mainly in industrial applications.

1. Fan and pump control (air flow volume, flow rate)
2. Transport control (conveyor, carriage)
3. Web processing control
4. Food processing control
5. Machine tool control

Knowing the load characteristics is extremely important for being able to utilize an inverter properly.

This is because focusing on load characteristics when forming a control method optimized for the specific system in use will allow you to dramatically cut down on energy usage, improve processing characteristics, and experience other benefits.

Typical load characteristics are shown in the diagram below.

Type	Load under decreased torque	Load under constant torque characteristics	Load under constant output characteristics
Characteristics	<p>→ Frequency (rotational speed)</p>	<p>→ Frequency (rotational speed)</p>	<p>→ Frequency (rotational speed)</p>
Feature	<p>A load requiring a torque that is nearly directly proportional to the square of the rotational speed. The amount of dynamic energy required is approximately directly proportional to the cube of the rotational speed.</p>	<p>A load requiring a nearly constant torque that is independent of the rotational speed. The dynamic energy required decreases directly proportionally to the decrease in rotational speed. (Conveyor, grinding machine, and other equipment)</p>	<p>A load requiring a torque that is inversely proportional to the number of turns of the motor. (Main axis of the machine tools and other sections)</p>

1.2

Practical Applications of Inverters



[Fan and pump control (air flow volume, flow rate)]

Previously, it was common to adjust the air flow volume and flow rate using a damper or valve in cases where a commercial power supply was used to run the fan and pump.

It is often difficult in such cases to cut down on the amount of energy used by the motor even by lowering the air flow volume or flow rate.

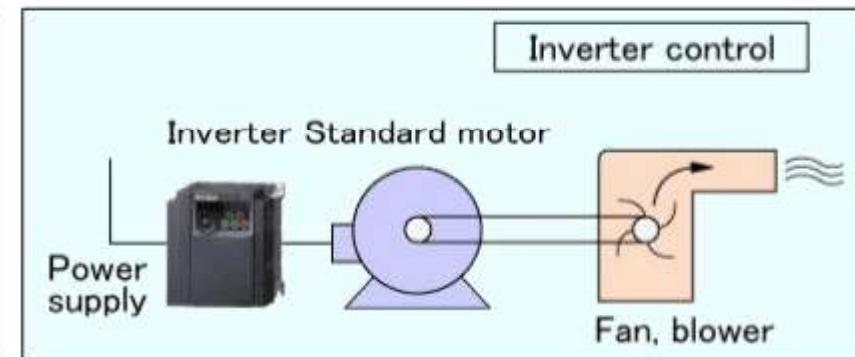
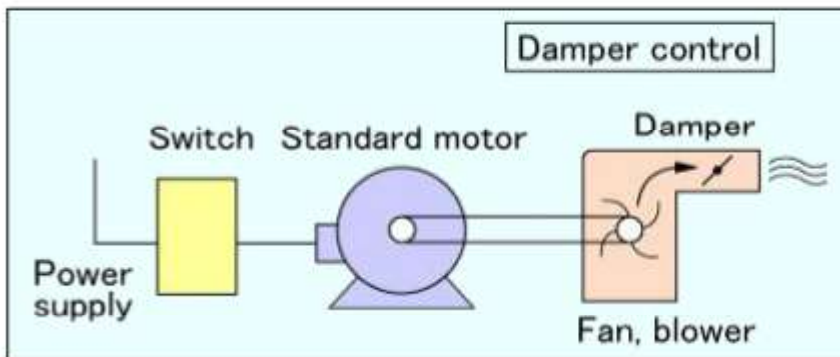

For fan and pump driving, the rotational torque is proportional to the square of the number of revolutions per minute and the amount of energy used to the cube of the number of revolutions per minute.

The use of inverter control enables energy usage to be cut dramatically, particularly in regions of rotation at low speed.

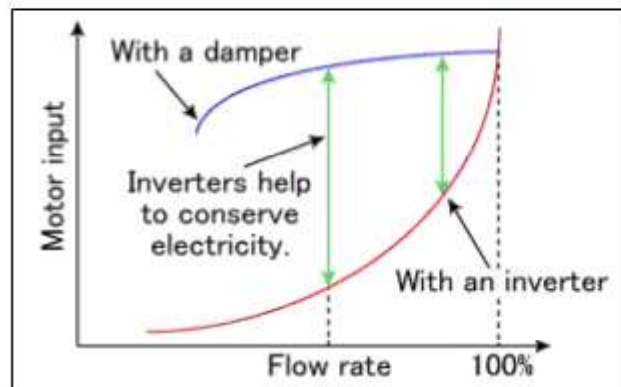

As shown, an inverter is a common energy-saving device used for fan and pump control.

1.2 Practical Applications of Inverters

Ventilating fan:

- | | |
|------------------------------------|---|
| Reasons for using inverters | <ul style="list-style-type: none">○ You can get more accurate temperature control and save energy by hooking up three ventilation fans to a single inverter in series and using the inverter to run the fans and control their rotational speeds. |
|------------------------------------|---|

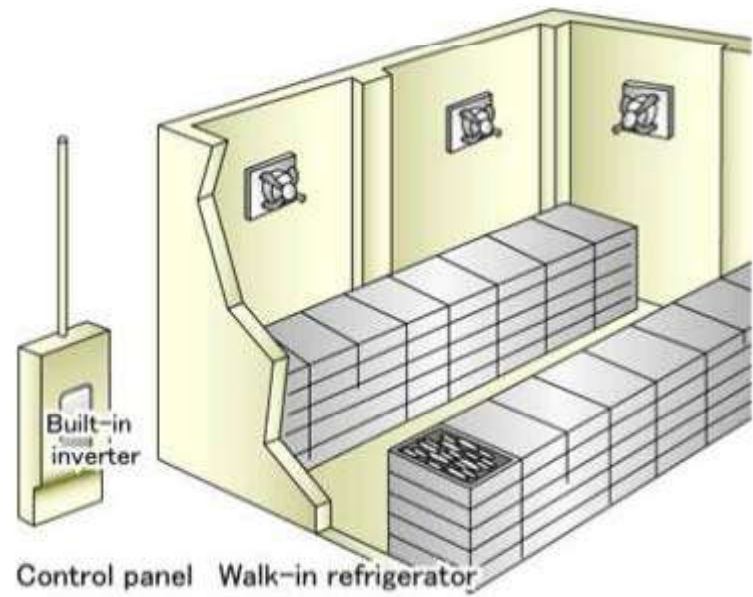

1.2

Practical Applications of Inverters



Cooling tower:

Reasons for using inverters

- They can be used to control temperature using a temperature sensor. This will help cut down on energy usage.
- They can be set to run in automatic mode.
- They can be run in quiet mode by adjusting the air flow volume. (Speed control for night operation)

*CAUTION: Be sure to install inverters indoors.

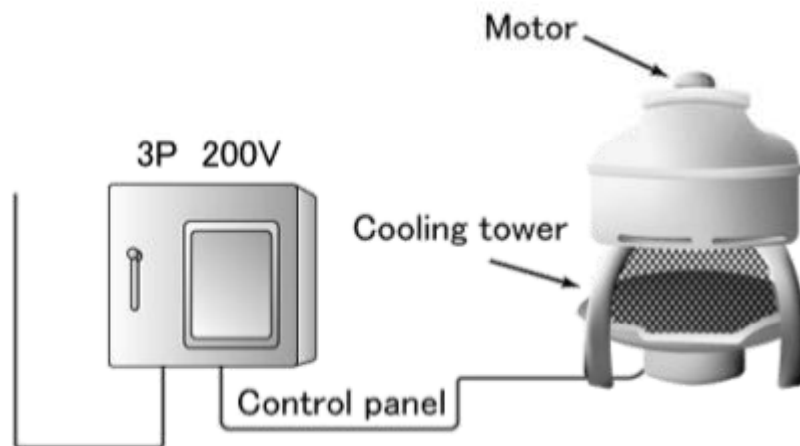

1.2

Practical Applications of Inverters



Screw conveyor:

Reasons for using inverters

- They enable you to adjust the amount of base material fed into the device with a single knob.
- They allow you to adjust the rotational speed of the screw conveyor and the amount of base material fed into the device to the appropriate amount.
- They can be used with external-use, general-purpose motors as well as other standard parts.

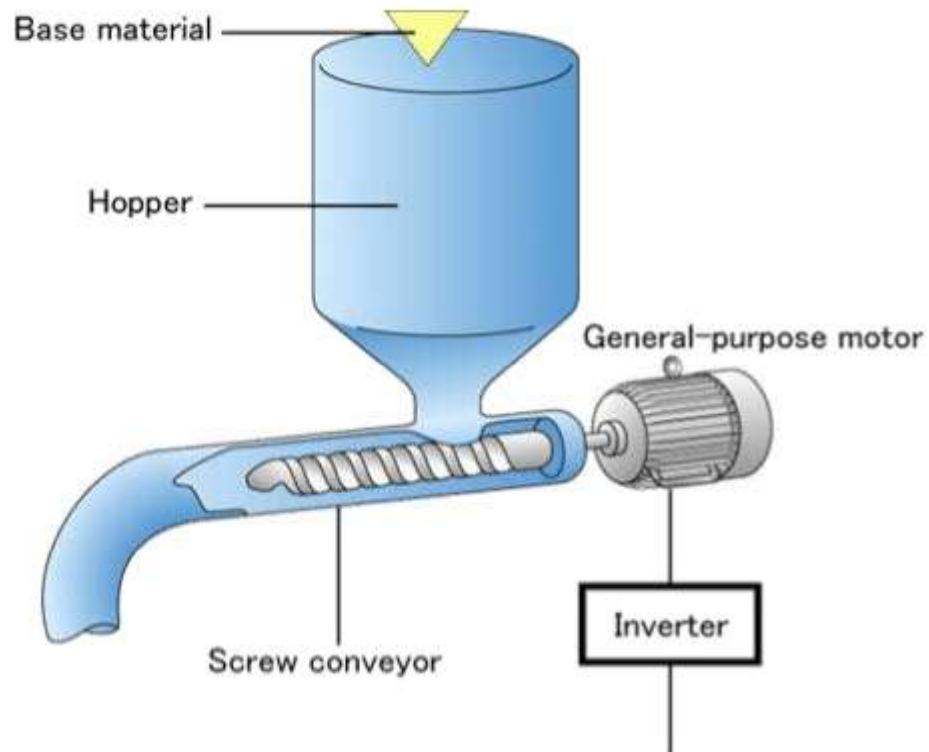

1.2

Practical Applications of Inverters



[Transport control (conveyor, carriage)]

Transport devices are indispensable elements in a variety of fields currently as industries become more sophisticated and automated.

Some of the advantages to using inverters with devices in this field include the following:

- They enable devices to be simplified and made more compact.
- They make it easier to set speed settings without needing a mechanical system.
- They work to prevent loads from collapsing due to impacts from slow starts or slow stops.
- They can be used in position control to a certain extent.

Belt conveyor:

Reasons for using inverters

- They can be used as soft starters and stoppers for a conveyor to prevent glass bottles filled with liquid that are being transported along a conveyor from tipping over and breaking or having their contents spill out.
- They can be used to improve operating efficiency using changes in speed when the type of glass bottle changes.
- They can be used in different usage environments to match the type of motor, whether waterproof, rustproof, outdoor, or other.

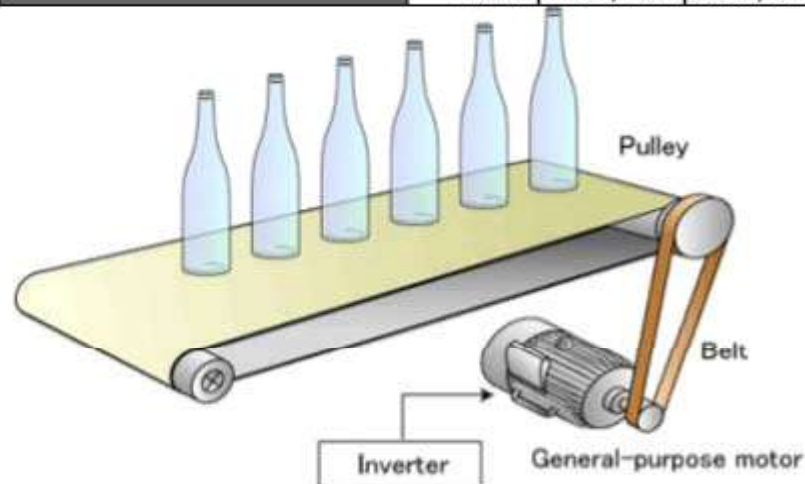

1.2

Practical Applications of Inverters



Carriage driving:

Reasons for using inverters

- They can be used to improve operating efficiency by adjusting the transport speed to the optimum speed based on operating conditions.
- They can be used to increase or decrease speed to lessen the impact of shocks on machinery or protect machinery from shocks.
- They enable regenerative braking torque to be used with inverters equipped with braking functions.
A regenerative converter for power supply can be used to generate control power to send regenerative energy back to the power supply if a greater braking function becomes necessary.
- They can be used indoors as they release no exhaust gases.

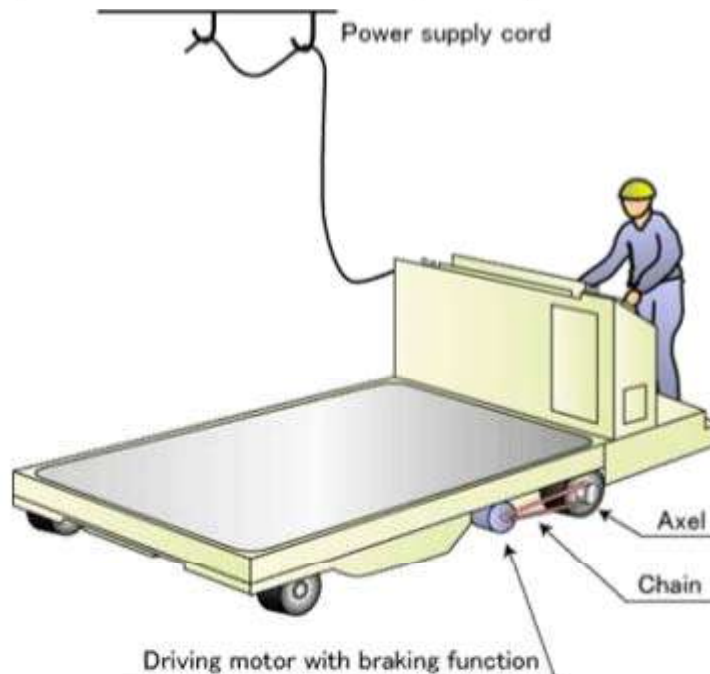

1.2

Practical Applications of Inverters



[Web processing control]

The web referred to here is a product that consists of long sheets of paper, film, rubber, cloth, or other material available on rolls.

The material is wound onto a roll as one elongated sheet that continues from the beginning of the roll all the way to the end.

The sheet needs to be processed to adjust the tension in the material as the sheet is advanced or rewound.

The product extends from the beginning of the role to the end. An example with the wound roll is given below.

This type of control is necessary for use in other fields such as with the winding of power lines and fiber optic cables.

Web material winding:

Reasons for using inverters	○ They can be used to detect actual tension in a sheet material to enable the material to be wound onto rolls at optimum tension.
	○ They can be used to mitigate the effects from variations in sheet material itself due to temperature and humidity and from changes in torque in the machinery.
	○ Both vector inverters and servos can be used to control torque. However, vector inverters are easier to use in cases in which the acceleration is somewhat gradual instead of sudden and the load inertia is high and the machinery is to be run continuously.

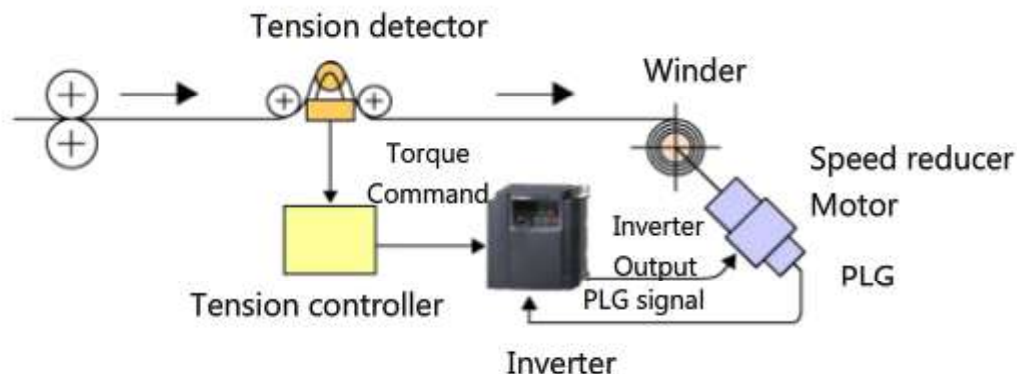

1.2

Practical Applications of Inverters



[Food processing control]

There is an increasing demand for greater sophistication in the manufacture of food products as well as higher quality and safer food processing methods.

Inverters are being used more and more often even in food processing because of this situation.

Noodle-making Machine:

Reasons for using inverters

- They can be used to fine-tune the feed speed of a flattening roller.
- They can be used to freely adjust the thickness of the noodles to the desired size.
- They help to simplify the machine controls.

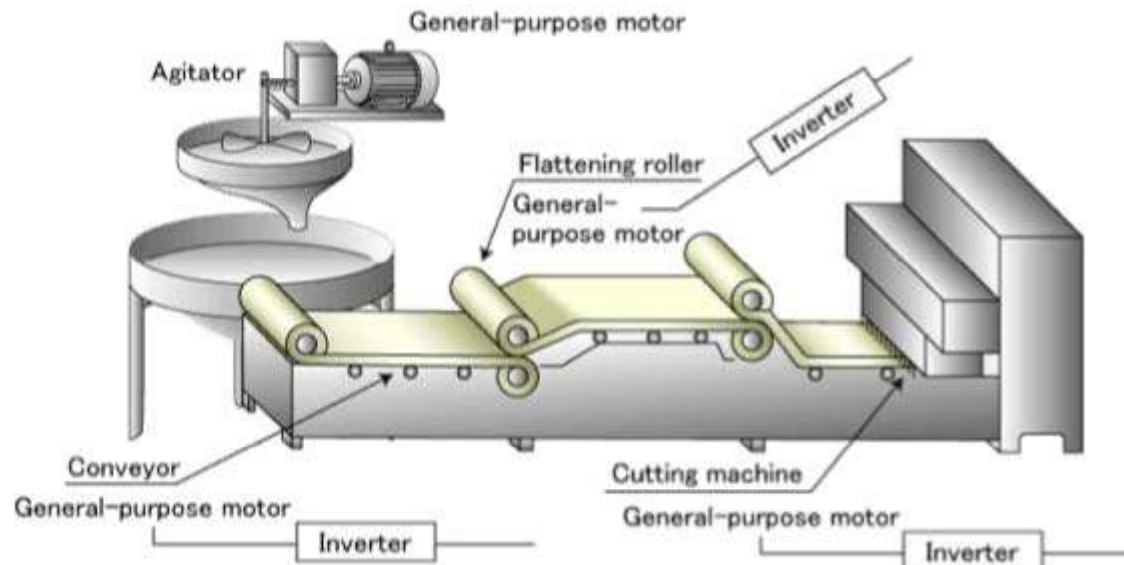

1.2

Practical Applications of Inverters



Tea processing machine:

Reasons for using inverters

- They can be used to optimize the speed of the furnace fan to match the amount of tea inserted into the machine.
- They can be used to improve tea quality.

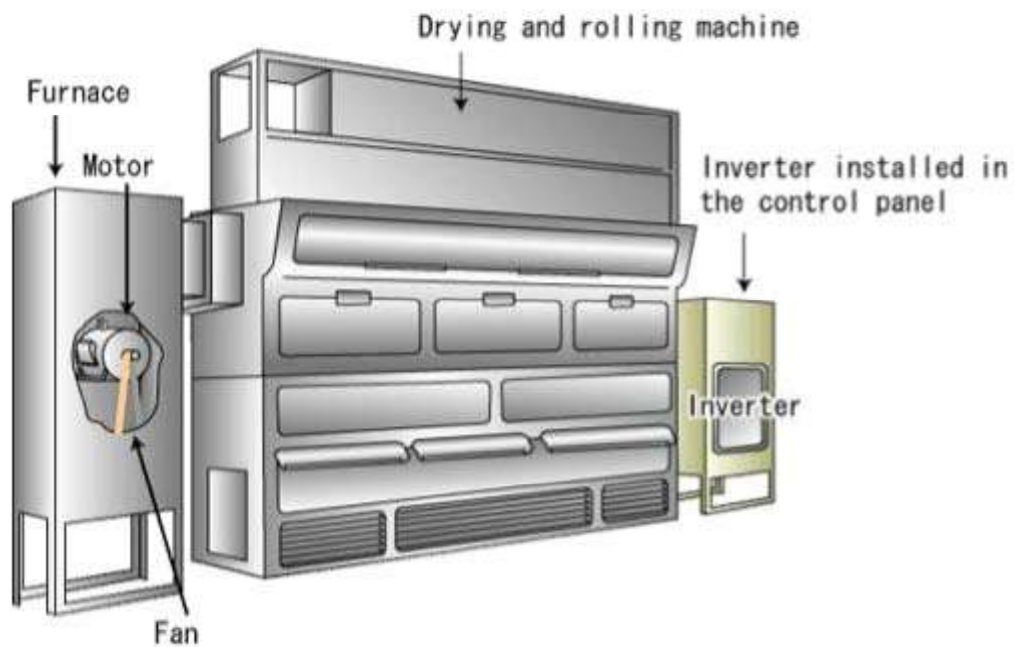

1.2

Practical Applications of Inverters



[Machine Tool Control]

Inverters are often used in the main axis in machine tools (the axis affixed to and used to turn the workpiece or tool). In particular, when high-precision processing is required, a combination of a vector inverter and position detector (pulse encoder) can be used to stop the main shaft at a set position (orientation function) and keep the motor at a constant speed even if the load changes using signal feedback from the detector.

Main axis driving for machine tools:

Reasons for using inverters

- Previously, the rotational speed of the main axis was controlled through variable pulley speed in response to the size of the workpiece. With inverter driving, however, the variable speed mechanism can be simplified to enable the machinery to be more compact.
- The processing accuracy of the workpiece can be improved because the rotational speed of the main shaft can be fine-tuned.

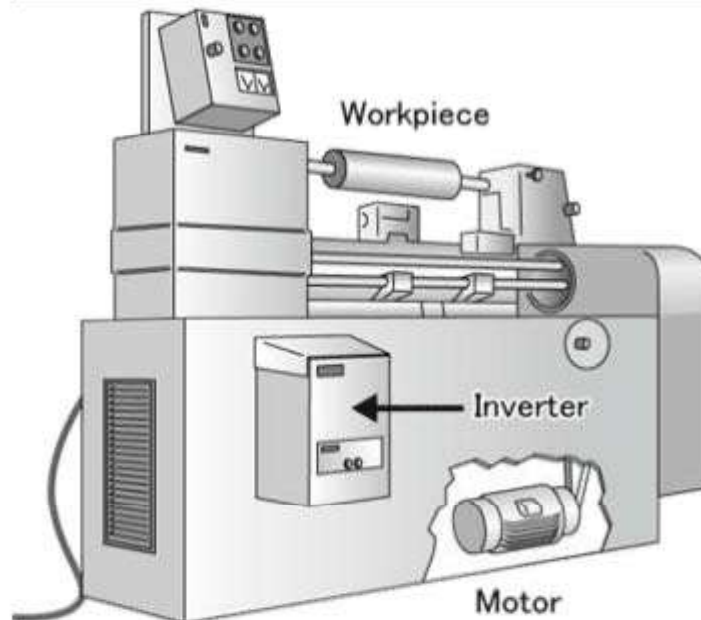

1.2

Practical Applications of Inverters



Woodworking Machinery:

Reasons for using inverters

- They help improve efficiency for wood cutting.
- They enable the carriage speed to be set to an optimal level according to the wood quality.
- They can be used to improve operating efficiency and stop the carriage at the set position.
- They work to protect the cutting blade during soft starts.

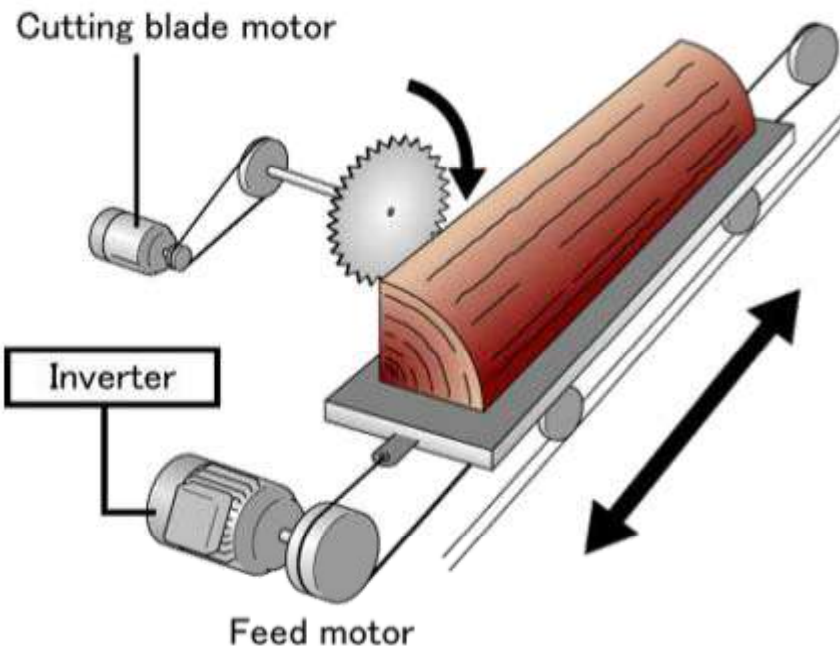

1.3 Inverter structure

The structure of an inverter used to produce a flexible set frequency from a fixed frequency supplied from an electric power company is shown.

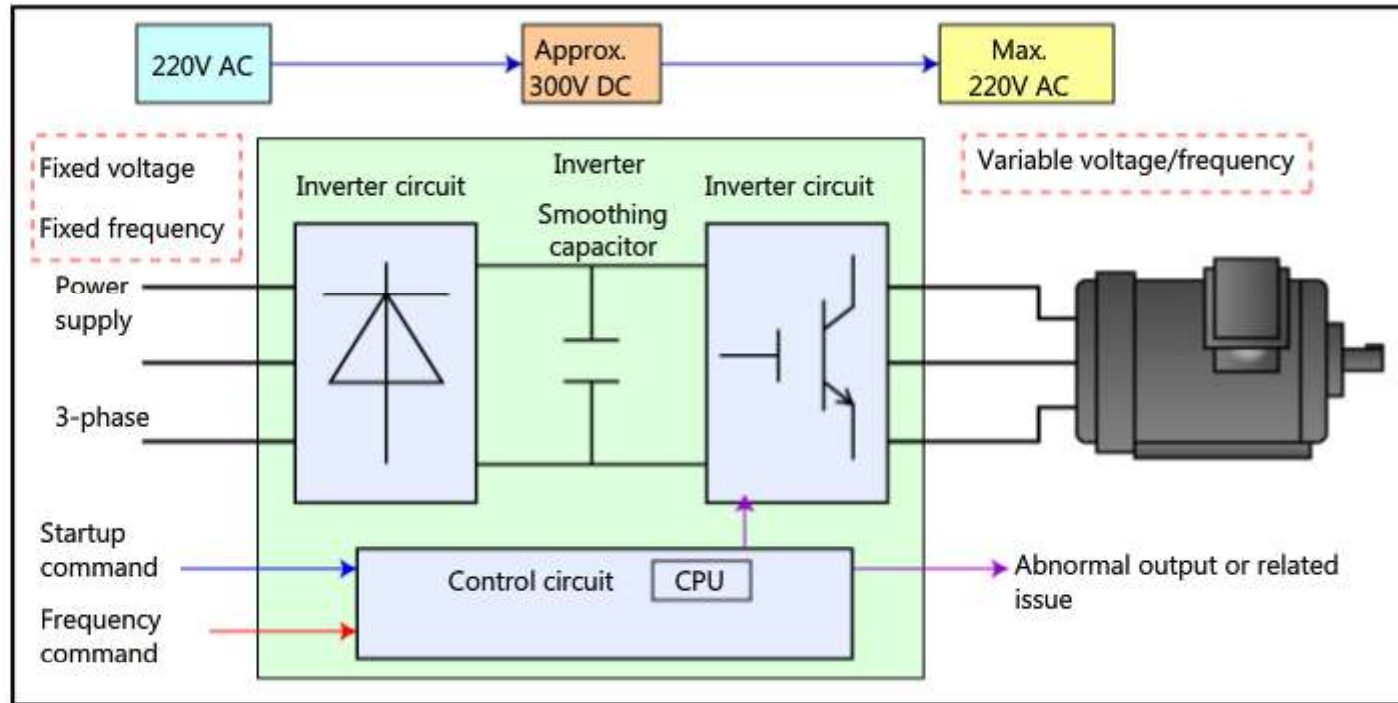

[Overview of the Structure of an Inverter]

Converter circuit	Converts AC into DC. Uses a semiconductor element that is known as a diode.
Smoothing capacitor	Works to smooth out a DC voltage that was converted by a converter circuit.
Inverter circuit	Used to produce an AC voltage from a DC voltage. This device, which is called an inverter, is the opposite of a converter in name and function. Used to supply a motor with a variable voltage/frequency that was produced. Uses semiconductor switching elements (IGBTs and similar parts) that can be turned on and off.
Control circuit	Controls the inverter circuit

1.3

Inverter structure



[Waveform Characteristics]

Just how do the input and output change when an inverter is used?

- Input current ... A current waveform that looks like a rabbit's ear [Includes higher-pitched components]
- Output voltage ... A waveform that looks like a collection of strips (rectangles) [Includes high-frequency components and voltage surge components]

This type of waveform is created from switching operations of semiconductor elements in an inverter.

Inverter input waveform

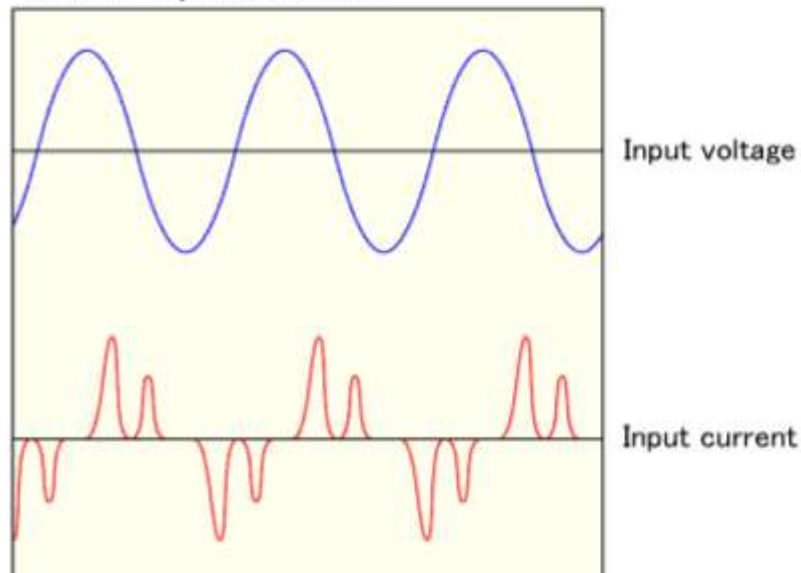

Inverter output waveform

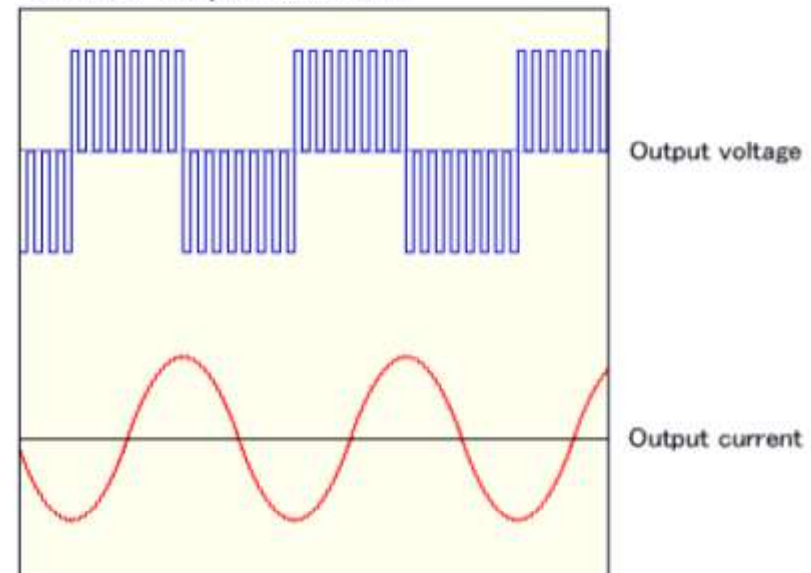

1.3 Inverter structure

[Operating Principles for the Converter Section]

(a) Operating Principles for the Converter Section

<How to produce a DC voltage from an AC voltage (commercial) power supply>

Let's consider this principle using a simple, single-phase AC voltage example.
To simplify our explanation, let's use resistor load conditions for this example.

The element used is a diode.

A diode only allows current to flow in one direction and not in the other according to the direction in which voltage is applied.



Utilizing this property, when an AC voltage is applied across A and B in a rectifier circuit, a voltage is also applied across the load in the same direction.

In other words, the AC voltage is converted (rectified) into a DC voltage.

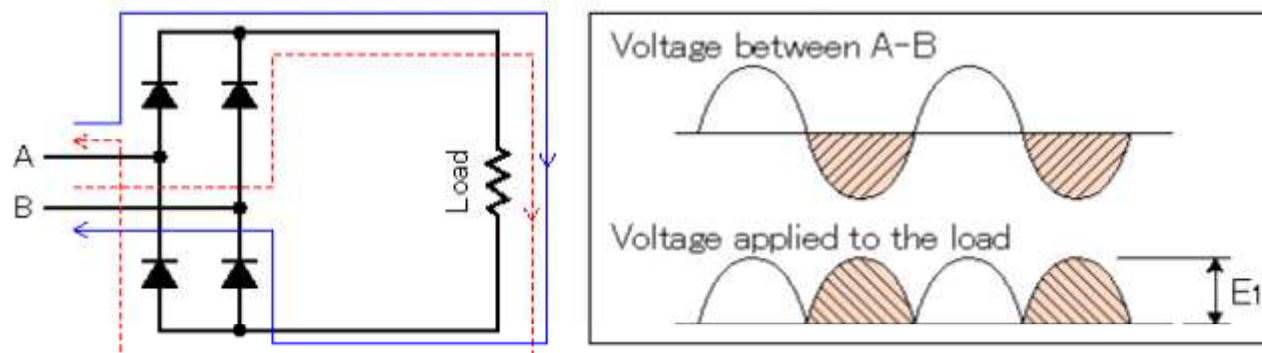

1.3

Inverter structure



[Operating Principles for the Converter Section]

(b) Operating Principles for the Converter Section

For 3-phase AC input, a combination of six diodes is used to rectify the waveform from the AC power supply to produce an output voltage like that shown in the diagram below.

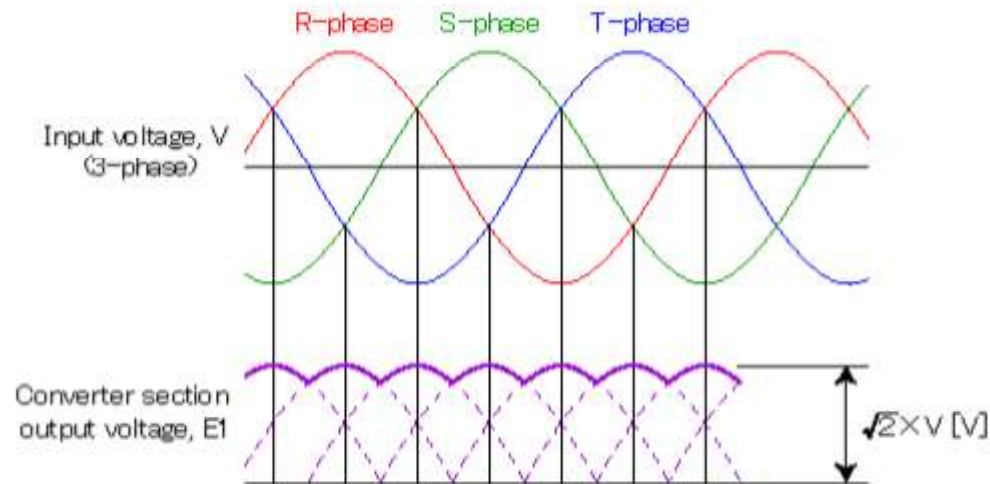

(c) Operating Principles for the Smoothing Circuit

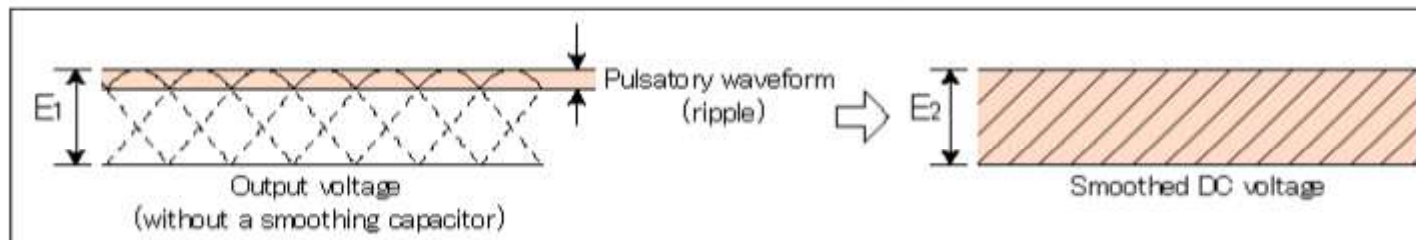

1.3 Inverter structure

[Operating Principles for the Converter Section]

(d) Inrush Current Limit Circuit

An explanation of the principles behind rectification was given using a resistor load, but in actual applications, a smoothing capacitor is used as the load.

A high inrush current flows through the circuit the instant a voltage is applied in order to charge the capacitor. In order to prevent the rectifier diode from becoming damaged due to this high inrush current, a resistor is inserted into the circuit in series to suppress the inrush current for a short time after the power is turned on. Once it has served its purpose, the resistor is shorted across its two terminals to produce a circuit that bypasses the resistor.

This circuit is referred to as an inrush current limit circuit.

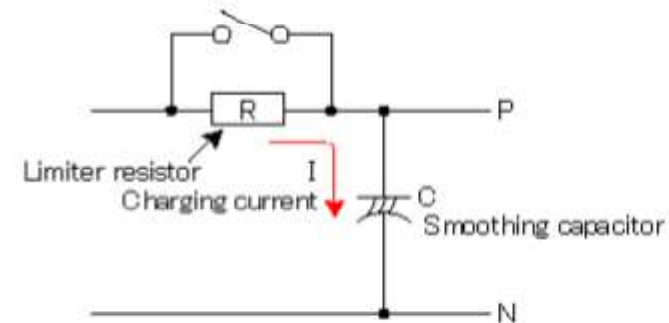

If an inrush current limit circuit is used, the current peak value can be decreased to prevent the converter module from becoming damaged.

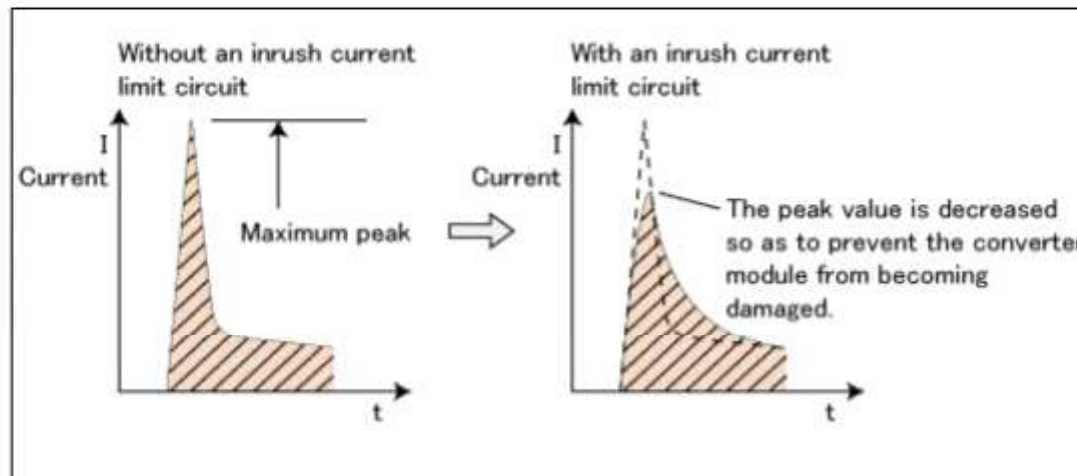

1.3 Inverter structure

[Operating Principles for the Converter Section]

(e) Input current waveform with capacitor load

An explanation of the principles behind rectification was given using a resistor load, but in actual applications, a smoothing capacitor is used as the load.

The input current waveform flow in this case occurs only when the AC voltage is higher than the DC voltage. This causes the waveform to be distorted as shown in the diagram and not a sine wave.

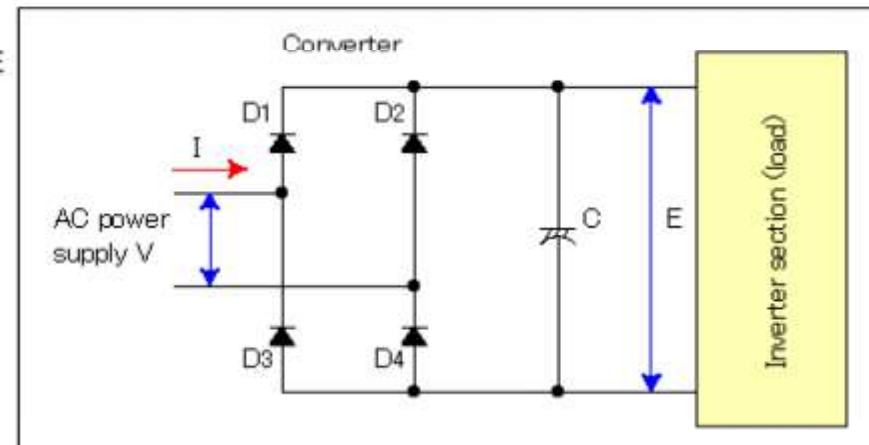
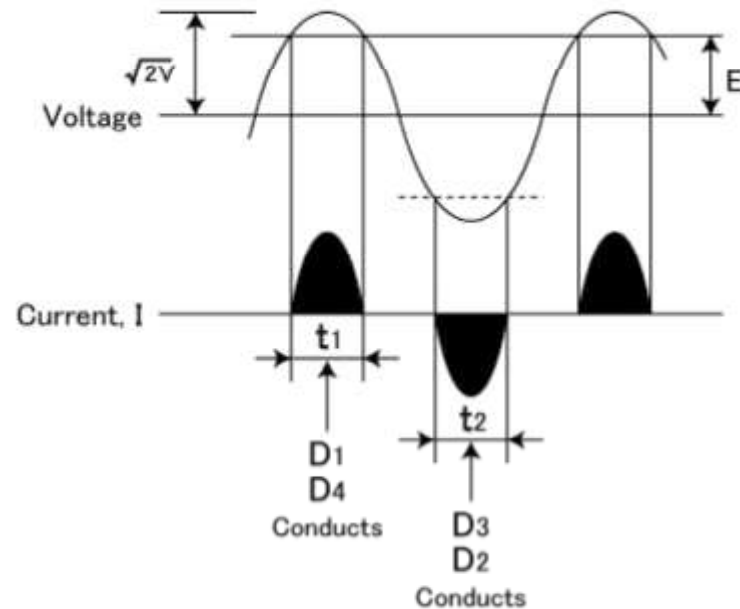

1.3

Inverter structure

[Operating Principles for the Converter Section]

<Summary>

Converter Principles

As described above, the converter section is made up of the following:

1. A converter
2. An inrush current limit circuit
3. A smoothing circuit

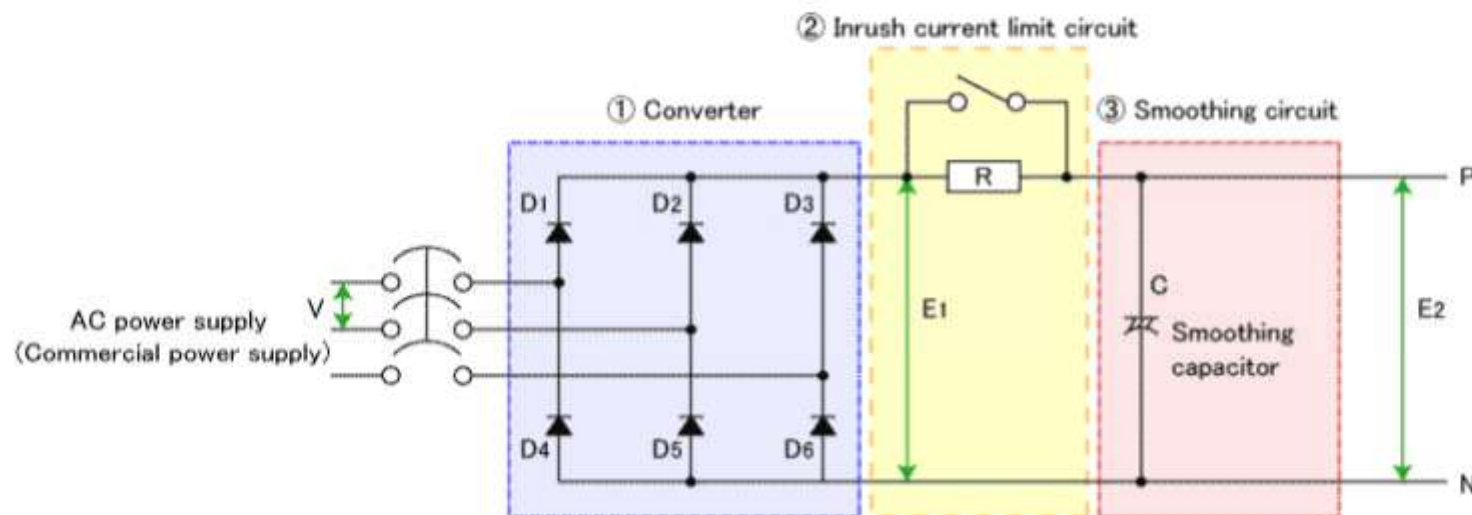

1.3 Inverter structure

[Operating Principles for the Inverter Section]

(a) How can you get AC voltage from DC voltage?

Let's consider this principle using a simple, single-phase AC voltage example.

Let's describe how this works using an example with a lamp used as the load instead of the motor below.

Four switches, S1 to S4, are connected to a DC voltage power supply, with the S1 and S4 switches paired up and also the S2 and S3 switches. As the paired switches are turned ON and OFF, current flows through the lamp as shown in the diagram below.

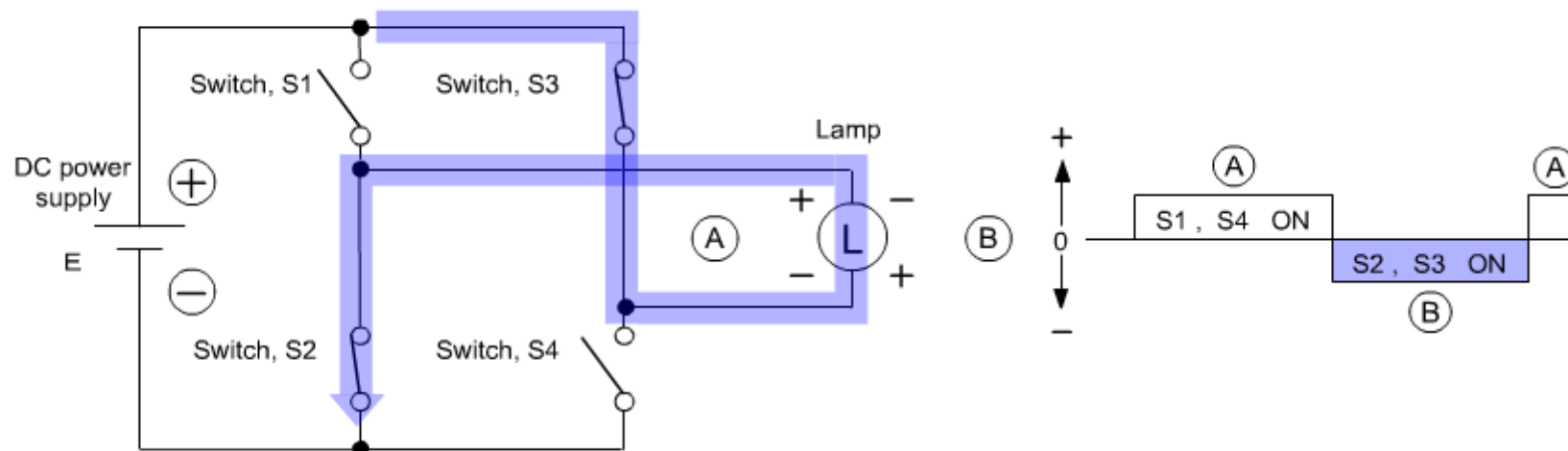

Current waveform

- When the S1 and S4 switches are turned on, current flows through the lamp in the A direction.
- When the S2 and S3 switches are turned on, current flows through the lamp in the B direction.

If these switch operations are repeated over a set period, the direction of current flow changes back and forth to produce an alternating current.

1.3

Inverter structure



[Operating Principles for the Inverter Section]

(b) How can you change the frequency?

The frequency changes as you change the length of time that the S1 to S4 switches are turned ON and OFF. For example, if you turn the S1 and S4 switches ON for 0.5 s and then the S2 and S3 switches ON for 0.5 s repeatedly back and forth, you will produce an alternating current that reverses in direction of flow once per second, which is equivalent to a frequency of 1 Hz.

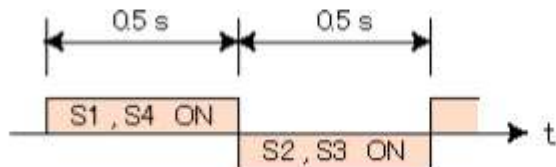

In general, the frequency is defined as $f = 1/t_0$ (Hz), where t_0 is the cycling time in seconds.

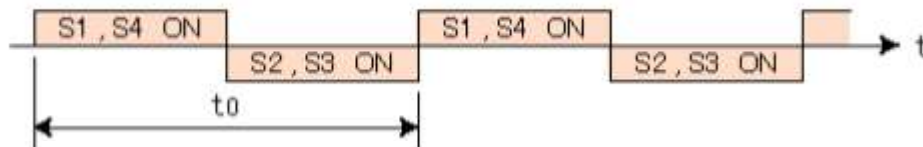

In other words, the frequency can be changed if this time, t_0 , is changed.

1.3

Inverter structure



[Operating Principles for the Inverter Section]

(c) How can you change the voltage?

The (average) voltage can be changed by changing the time ratio at which the switches are ON/OFF by changing the cycling time, t_0 , to a shorter cycling time for turning the voltage ON/OFF. The frequency for these short pulses is referred to as a carrier frequency.

For example, if the ratio for ON time for switches S1 and S4 is cut in half, the (average) output voltage becomes an AC voltage equal to $E/2$, or half of the DC voltage, E .

To lower the (average) voltage, lower the ratio for ON time and to raise the (average) voltage, raise the ratio for ON time.

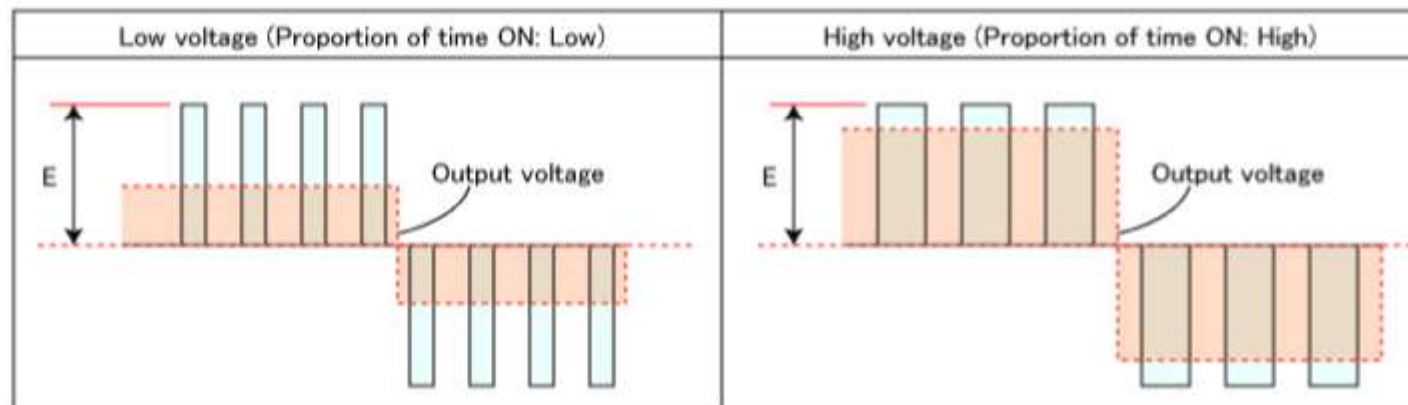
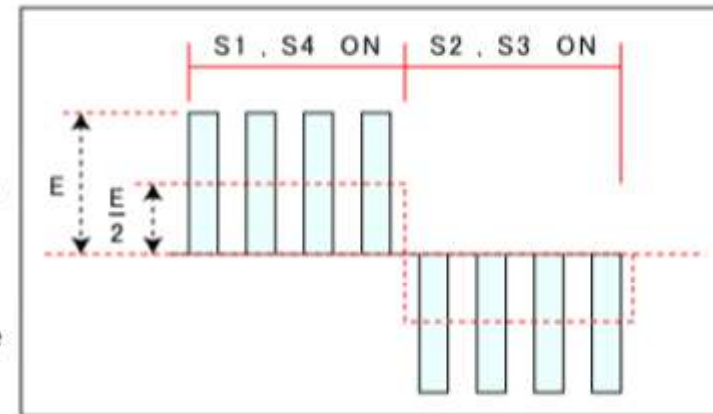

The pulse width and ON/OFF ratio are controlled in order to change the voltage. This type of control method is referred to as pulse width modulation (PWM) and, presently, it is commonly used in inverters and other electronic components.

1.3 Inverter structure

[Operating Principles for the Inverter Section]

(d) How about with 3-phase AC voltage?

The basic structure of a 3-phase inverter circuit and 3-phase AC voltage is shown below. If you change the order in which the six switches are turned ON/OFF, the sequence for U-V, V-W, and W-U changes. This can be used to change the direction of motor rotation.

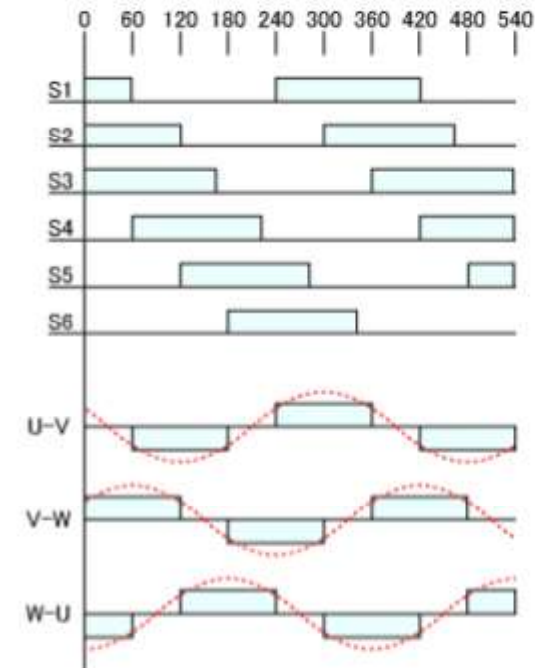
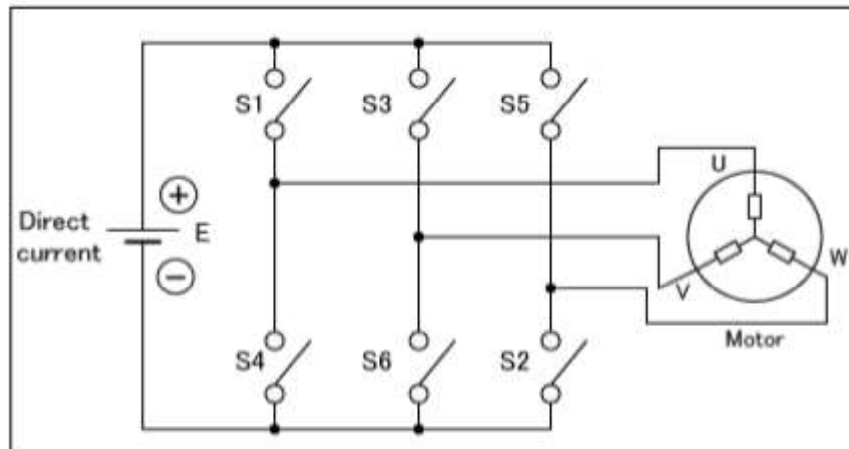

Note that semiconductor elements are used for the actual switches discussed above for voltage switching, which enables the switches to be turned ON/OFF at extremely high speed.

1.4**Inverter control methods**

The only general-purpose inverter available for industrial fields in the 1980s was the V/F control inverter. However, a (speed) sensorless control method was introduced in the 1990s with the intention of increasing torque in the lower regions for V/F control.

Inverter performance increased dramatically due to advancements in hardware technology and control theory technology including semiconductors.

Vector control with PLG began to be applied for induction motors starting in the 1990s in fields requiring high-precision speed control.

A list of typical inverter control methods is given in the table below, mainly for methods involving speed control.

In broad terms, just remember that the performance and accuracy increase as you go right in the table below a control method but the flexibility and economic efficiency decrease.

For sensorless control, the method and name may differ by manufacturer. The method shown in the table is the one developed by Mitsubishi Electric.

1.4

Inverter control methods



Control method	Voltage-frequency characteristics (V/F) control	Sensorless control		Vector control with PLG
		Field-oriented control	Real sensorless Vector control	
Speed control range	1 : 10 (6 Hz to 60 Hz: Power lines)	1 : 120 (0.5 Hz to 60 Hz: Power lines)	1 : 200 (0.3 Hz to 60 Hz: Power lines)	1 : 1500 (1 r/min./1500 r/min.: Power lines, with regeneration)
Response	10 to 20 (rad/s)	20 to 30 (rad/s)	120 (rad/s)	300 (rad/s)
Speed control	(YES)	(YES)	(YES)	(YES)
Torque control	(NO)	(NO)	(YES)	(YES)
Position control	(NO)	(NO)	(NO)	(YES)
Outline	With the most common type of inverter control method, the voltage and frequency are kept controlled to constant values.	In order to resolve the issue with drops in low-speed torque in V/F control, a control method is used that corrects output voltage using vector calculations for motor current.	In standard motors without PLGs, control is achieved through calculations and estimates of motor speed from the motor constant and voltage/current characteristics.	This method divides motor current into field-oriented components and torque-generated components and controls each type independently of the other. This enables torque and position to be controlled at high precision and high response.
General-purpose	This method is extremely flexible for use with standard motors in that it has few control elements.	This method requires a motor constant, but the circuit structure is relatively simple as there are few control elements.	This method requires a motor constant as well as adjustment of the control gain.	This method requires a motor with a PLG as well as adjustment of the control gain.
Applicable motors	Standard motor (without PLG)	Standard motor (without PLG)	Standard motor (without PLG)	Standard motor (with PLG) Dedicated vector control motor

Now that you have completed all of the lessons of the FA Equipment for Beginners (Inverters) Course, you are ready to take the final test. If you are unclear on any of the topics covered, please take this opportunity to review those topics.

There are a total of 10 questions (21 items) in this Final Test.

You can take the final test as many times as you like.

How to score the test

After selecting the answer, make sure to click the **Score** button. Failure to do so will not score the test. (Regarded as unanswered questions.)

Score results

The number of correct answers, the number of questions, the percentage of correct answers, and the pass/fail result will appear on the score page.

Correct answers : 3

Total questions : 10

Percentage : 30%

To pass the test, 60% of correct answers is required.

Proceed

Review

Retry

- Click the **Proceed** button to exit the test.
- Click the **Review** button to review the test. (Correct answer check)
- Click the **Retry** button to retry the test multiple times.

What is an Inverter?

Select the correct statement from the following explanations.

- An inveter is device that can be used to freely and continuously change the output torque or a motor efficiently.
- An inveter is device that can be used to freely and continuously change the rotational speed of a motor efficiently.
- An inverter is a device that can be used to turn motor rotation ON/OFF.

Score

Back

Motors used in industrial inverters

Select the type of motor used in industrial inverters.

- DC motor
- Single-phase induction motor
- 3-phase squirrel-cage (induction) motor
- Synchronous servo motor

Score

Back

Rotational speed of a 3-phase motor

Fill in the blanks indicated by the parentheses in the sentences below with the appropriate terms from the explanation on using an inverter to control the rotational speed of a motor.

The rotational speed of a 3-phase motor is directly proportional to the and inversely proportional to the of the motor.

In an inverter, of the two properties given, motor rotation is controlled by freely changing the .

Test**Final Test 4**

Torque generated by the motor

Fill in the blanks in the formula shown for calculating the amount of torque generated by a motor with the appropriate terms.

Rated torque, $T_m = 9550 \times$ / (N•m)

Practical Applications of Inverters

Select the correct statement or statements from the explanation of air flow volume and flow rate control (more than one may be correct).

- In order to reduce air flow volume, the rotational speed of the motor must be increased.
- In order to reduce air flow volume, the rotational speed of the motor must be decreased.
- Energy is conserved when the air volume is low.
- The volume of air flow has no effect on energy usage.

[Score](#)[Back](#)

Test Final Test 6

Internal structure of an inverter

Fill in the blanks in the explanation of the internal inverter structure with the appropriate terms.

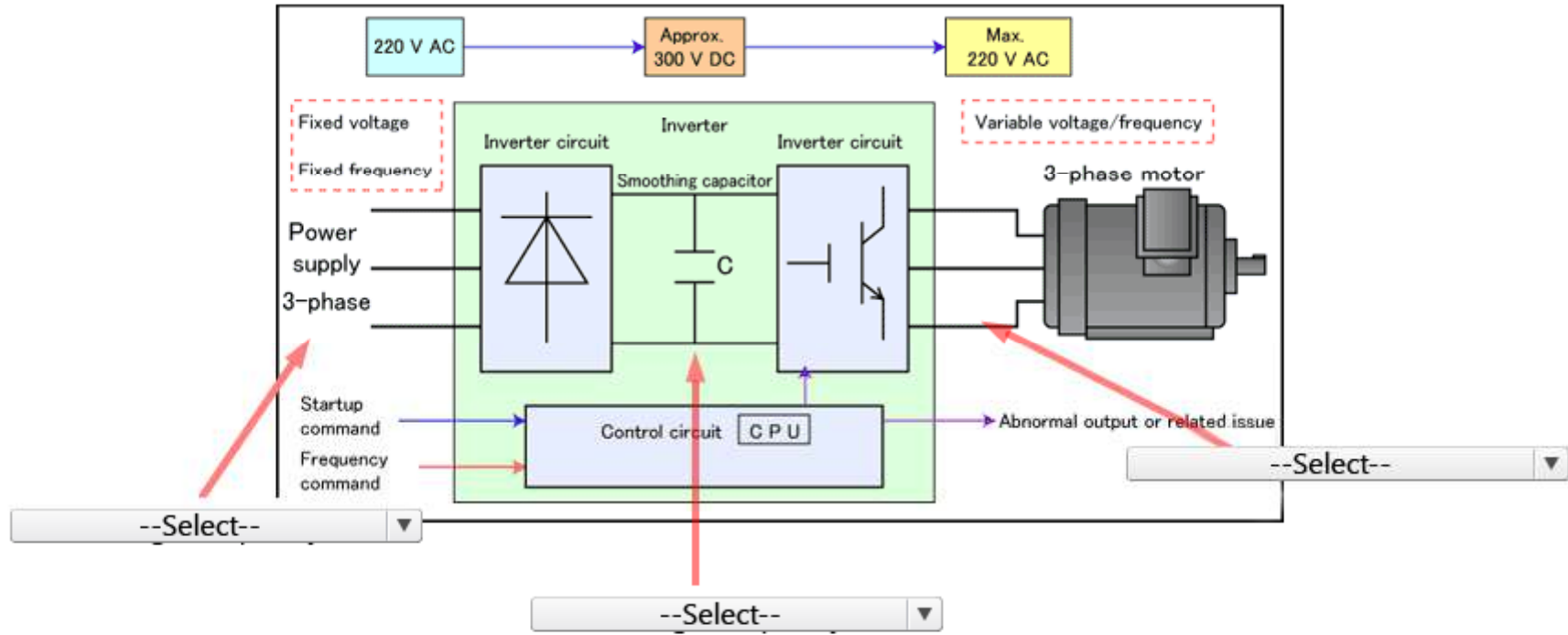

Score Back

Test

Final Test 7

A circuit used to convert from AC into DC inside an inverter

Select the corresponding circuit from the explanation on circuits used to convert AC voltage into DC voltage.

--Select-- ▾

The AC power supply voltage is rectified and converted into DC voltage.

--Select-- ▾

Pulse ripple components in the rectified DC voltage are removed.

--Select-- ▾

A high inrush current is prevented from flowing through the circuit when the power supply is turned ON.

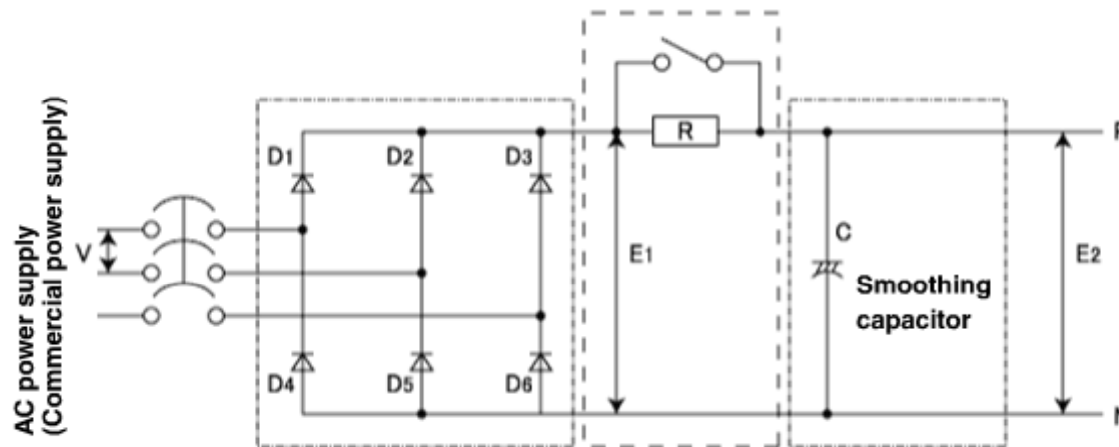

Score

Back

A circuit used to convert from DC into AC inside an inverter

Select the correct statement from the explanation on converting DC to AC.

- The DC voltage is turned ON/OFF using relay contacts.
- The DC voltage is turned ON/OFF using semiconductor components (transistors, etc.).
- The DC voltage is turned ON/OFF using smoothing capacitors.

Score

Back

Method used for conversion into an AC voltage with variable frequency

Fill in the blanks with the proper terms from the explanation on how to create an AC voltage with variable frequency.

The frequency is changed through control of the of the ON/OFF for the switches.

The output voltage is changed through control of the of the ON/OFF for the switches.

Advantages to using inverters

Select the items related to the advantages of using inverters in equipment.

--Select--

Inverters can be used to cut energy costs by adjusting air flow volume and flow rate.

--Select--

The use of inverters makes mechanism parts for changing speeds such as variable speed belts unnecessary.

--Select--

Inverters can be used to alleviate shocks to machinery during equipment startup/shutdown.

--Select--

Inverters can be used in equipment with existing motors.

Score

Back

You have completed the Final Test. Your results are as follows.
To end the Final Test, proceed to the next page.

Correct answers : 0

Total questions : 10

Percentage : 0%

Proceed

Review

Retry

You failed the test.

You have completed the **FA Equipment for Beginners (Inverters)** Course.

Thank you for taking this course.

We hope you enjoyed the lessons and the information you acquired in this course is useful for configuring systems in the future.

You can review the course as many times as you want.

Review

Close