

PLC CC-Link IE Field Network

This course is an online training system (e-learning) intended for first-time users of the CC-Link IE Field Network.

Introduction Purpose of the Course



This course is designed for first time users to provide a basic knowledge of the CC-Link IE Field Network. Working through this course will help impart a better understanding of data communications between programmable controllers and remote I/O stations (field I/O connections). Specifically, this course covers the data transfer mechanism, network specifications and settings, and how to start up the network.

Introduction Course Structure

The contents of this course are as follows.
We recommend that you start from Chapter 1.

Chapter 1 - Overview of CC-Link IE Networks

Fundamentals of the CC-Link IE Control and CC-Link IE Field networks.

Chapter 2 - Specifications and System Configuration

More detailed information about CC-Link IE Field specifications and system configuration.

Chapter 3 - Distributed Control using Local Stations

Learn how to create a CC-Link IE Field network using local stations for distributed control and confirm its operation.

Chapter 4 - Remote I/O Control using Remote Stations

Learn how to create a CC-Link IE Field network using remote stations for remote I/O control, perform troubleshooting, and confirm network operation.

Chapter 5 - Final Test

Passing grade: 60% or higher.

Introduction How to Use This e-Learning Tool



Go to the next page		Go to the next page.
Back to the previous page		Back to the previous page.
Move to the desired page		"Table of Contents" will be displayed, enabling you to navigate to the desired page.
Exit the learning		Exit the learning. Window such as "Contents" window and the learning will be closed.

Introduction **Precautions for Use**



Safety precautions

When you learn by using actual products, please carefully read the safety precautions in the corresponding manuals.

Precautions in this course

- The displayed screens of the software version that you use may differ from those in this course.

This course is for the following software version:

- GX Works2 Version 1.39R

Chapter 1 Overview of CC-Link IE

This chapter explains the basics of CC-Link IE networks and how they communicate.

CC-Link IE is an abbreviation that stands for "Control and Communication Link using Industrial Ethernet"

All CC-Link networks are "open" as opposed to proprietary, which means that detailed network specifications are available for any company to integrate CC-Link networks into their products, thus encouraging widespread adoption.

Currently two, gigabit Ethernet versions of CC-Link IE are available: The CC-Link IE Controller Network and the CC-Link IE Field Network.

1.1 The Necessity of Industrial Networks

1.2 CC-Link IE Basics

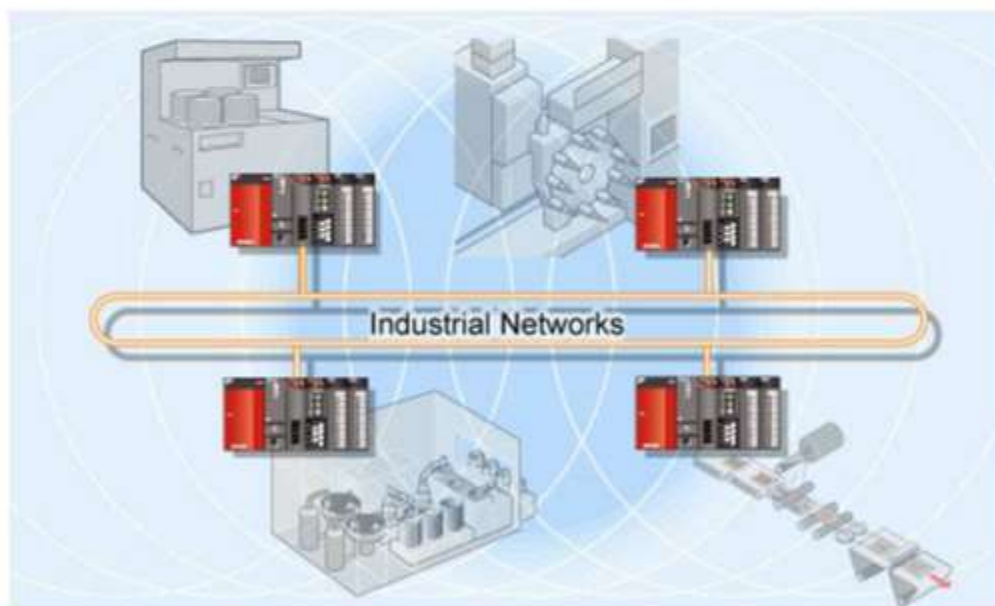

1.1

The Necessity of Industrial Networks

Before starting on the main subject, let's review the reasons why we need an FA network.

Need for information exchange through networks

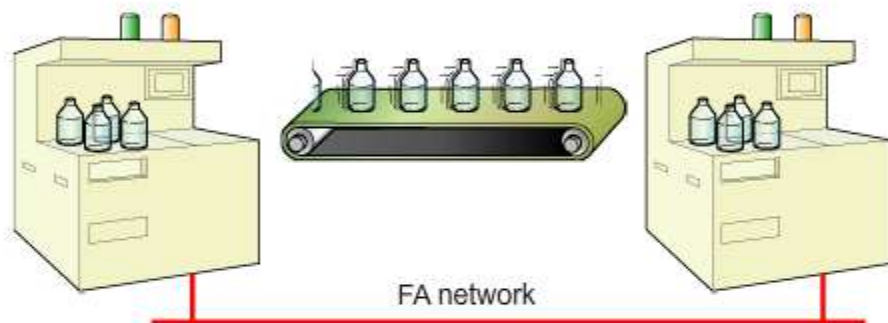

In this way, the FA network enables convenient exchange of information between distributed devices.

Click  to proceed.

1.2

CC-Link IE Basics

This section covers some basic information about CC-Link IE networks including specifications, communication methods, and an example system.

1.2.1

Network Topology

Different network cabling configurations, or topologies, may be desirable in different situations, depending on the requirements of the system. CC-Link IE Field networks may be organized using any one of the following topologies. (In addition, a line and star combination may be used.)



Line topology: Linear "daisy chain" configuration

- End points have only a single connection
- An issue with a single cable or station may potentially cut off still functioning network segments.

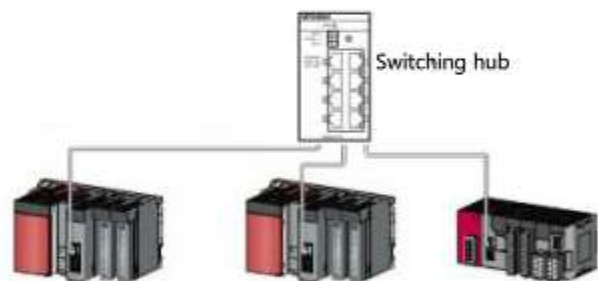

Star topology: Every station is connected to a central hub

- Cables all connect to a central location
- A single cable or station failure will be unlikely to effect the rest of the network.
- However, failure of the hub would bring down the entire network.
- Hubs may be cascaded (hubs connected directly to one another)
- Can be combined with line topology



Ring Topology: circular connection configuration

- Similar to line topology, but no end points (they are connected)
- A single cable or station failure will not effect the network's ability to maintain communications.

1.2.2 Type of Industrial Communication

Most industrial networks can be identified as serving one of the two following purposes explained in the table below.

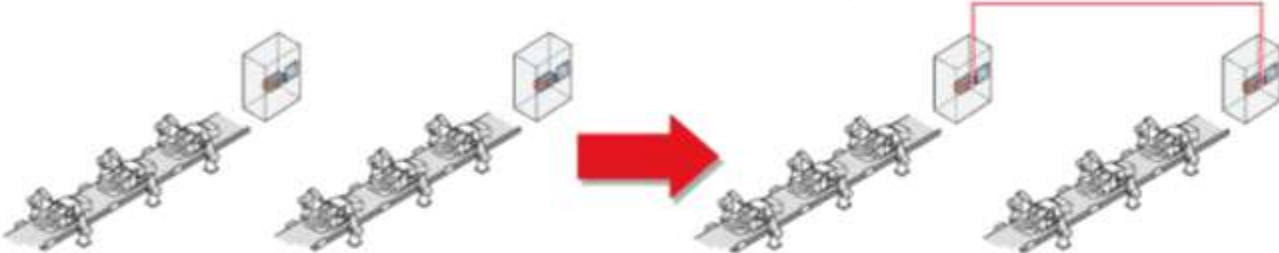
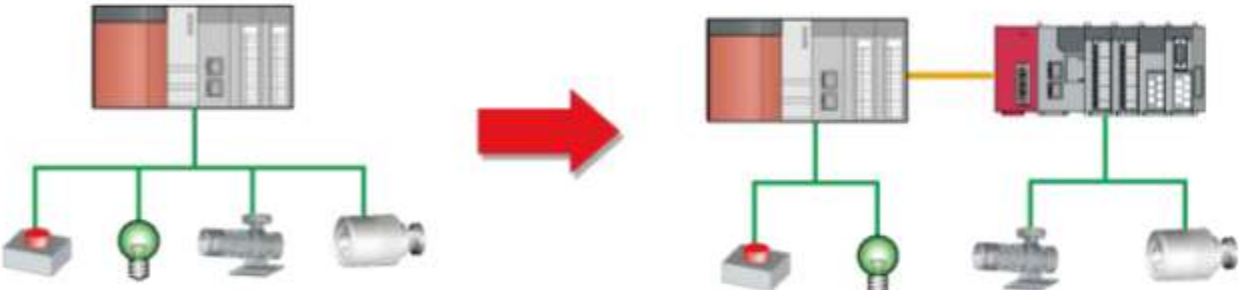
Purpose of the network	Explanation
Information exchange (cyclic transmission by the master station and local stations)	<p>Information is exchanged between programmable controller systems. This allows coordination between cells, lines, machines, processes, etc. This type of information exchange is also suited for process load sharing, traceability, remote maintenance, and many other functions.</p> 
Distributed I/O allocation (cyclic transmission by the master station and remote stations)	<p>Distributed I/O networks connect remote I/O stations with programmable controllers. Compared to all inputs and outputs being connected directly back to the programmable controller, this offers many advantages such as reduced wiring, improved reliability and maintenance capabilities, greater maximum distance between the I/O device and the programmable controller, and so on.</p> 

The CC-Link IE Field network can fulfill the purpose of both network types.

1.2.3 CC-Link IE Networks Compared

There are two types of CC-Link IE networks, the Controller Network, and the Field Network.

These networks are compared in the table below.

	CC-Link IE Controller Network	CC-Link IE Field Network
Features	<div style="display: flex; justify-content: space-around;"> <div style="border: 1px solid black; border-radius: 10px; padding: 2px 5px; background-color: #FFD700; color: black;">Large Capacity</div> <div style="border: 1px solid black; border-radius: 10px; padding: 2px 5px; background-color: #FFD700; color: black;">High Reliability</div> <div style="border: 1px solid black; border-radius: 10px; padding: 2px 5px; background-color: #FFD700; color: black;">Long Distance</div> </div>	<div style="display: flex; justify-content: space-around;"> <div style="border: 1px solid black; border-radius: 10px; padding: 2px 5px; background-color: #FFD700; color: black;">Multipurpose</div> <div style="border: 1px solid black; border-radius: 10px; padding: 2px 5px; background-color: #FFD700; color: black;">Flexible Cabling</div> </div>
Network purpose	Distributed control	Distributed control, remote I/O control
Physical communication medium	Optical fiber cable: Expensive and requires skill for cabling High noise tolerance	Twisted paired cable: Less expensive and relatively easy cabling
Topology	Ring: Featuring higher reliability than dual loop	Star, line, and ring: Featuring a high degree of freedom for cabling
Max. number of device points	Word: 128k points; Bit: 32k points	Word: 16k points; Bit: 32k points
Fault tolerance	Control station transition: Operating even when the control station fails	-
Max. station-to-station distance	550m	100m
Max. total distance	550 (m) × 120 (maximum number of connected stations) = 66 (km)	Line topology: 100 (m) × 120 (maximum number of connected stations) = 12 (km)

This section explains the CC-Link IE Field Network.

1.2.4 Communication Mode

CC-Link IE networks transfer data using two basic modes of communication:

- Cyclic transmission
- Transient transmission

The following table provides an summary of each mode.

Function	Description	Communication method
Cyclic Transmission	Data in a specified memory area is shared with all other stations on the network and refreshed automatically on a regular basis.	Automatic: Communication continuously takes place, based on the configuration of network parameters.
Transient Transmission	Data is sent and received only when there is an active communication request between stations. And when an active communication request exists, the transmission timing follows that of cyclic transmission.	Via program: Communication is performed using dedicated instructions which are executed by a user program.

Both the CC-Link IE Control and CC-Link IE Field networks support the simultaneous use of cyclic and transient transmission.

The remainder of chapter 1 explains cyclic transmission, which is the primary means by which programmable controllers and remote I/O stations share information.

1.2.5 Cyclic transmission

The following is an example program that uses devices which communicate via cyclic transmission.

Station No. 0 is the master station in the example, thus the X and Y link transfer bits are swapped (X inputs in the master station become Y outputs in slave stations and vice-versa). When X0 turns on, the Y1000 link transfer bit is used to turn on the X1000 bit in the corresponding station.

Station No. 0
programmable controller

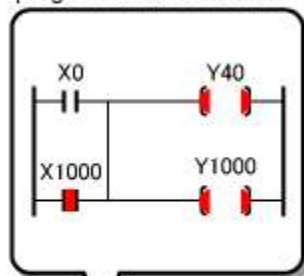

Station No. 0

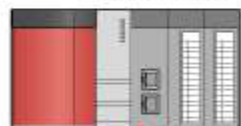

Station No. 1
programmable controller

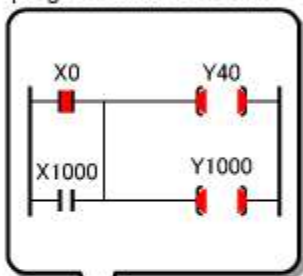

Station No. 1



REPLAY

Station No. 0 → Station No. 1

Station No. 0 ← Station No. 1

- (1) Contact [X0] of the programmable controller of Station No. 1 is turned ON.
- (2) Coils [Y40] and [Y1000] of the programmable controller of Station No. 1 are turned ON.
- (3) Contact [X1000] of the programmable controller of Station No. 0 is turned ON via the network.
- (4) Coil [Y40] of the programmable controller of Station No. 0 is turned ON.

By using cyclic information exchange, programs can be created quickly and easily, without worrying about the status of network transmissions.

* The example system above is a CC-Link IE Field network using cyclic transmission (for distributed control). It has two stations, a master station (No. 0) and a local station (No. 1).

1.2.6 Cyclic Transmission

Transmission of data over the CC-Link IE Field Network occurs during regular intervals and does not rely on packet collision detection.

Each station connected to the network takes turns sending data to the other stations. Only one station at a time may send data, based on a virtual "baton" or token. This method of communication timing control is known as "cyclic transmission". The period of time required for each station to take a turn sending data is called a "link scan".

An example of cyclic transmission timing is shown below.

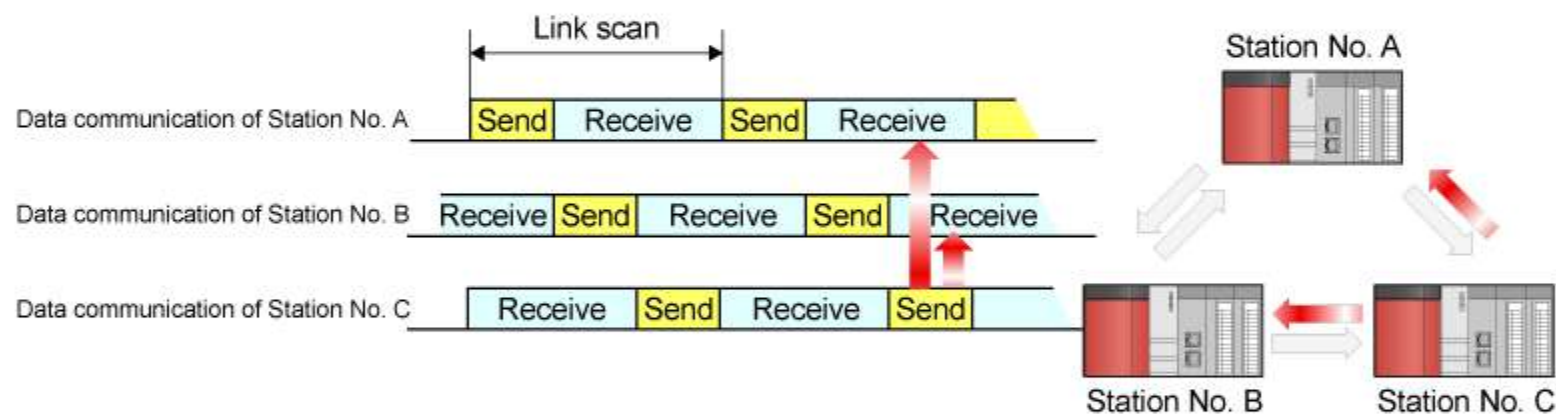

Key feature of CC-Link IE networks:

Cyclic transmission provides the ability for each station to reliably send data to all other stations on a turn-by-turn basis, regardless of the amount of data or number of stations on the network. It ensures that communication is timely, consistent, and reliable which makes it well suited for the control of production equipment.

1.2.7 CC-Link IE Field Station Types

The following diagram illustrates how station types are determined by their function.

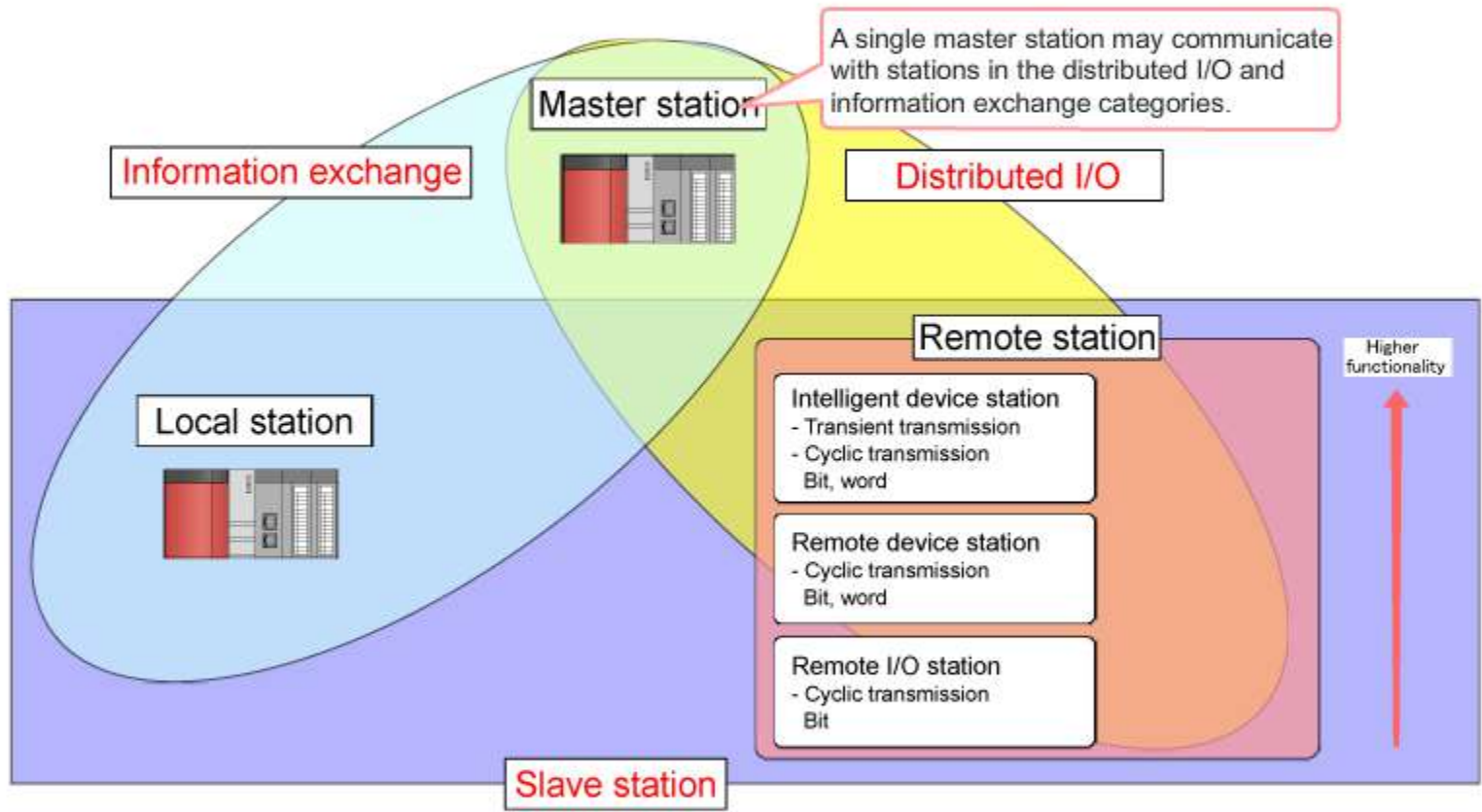

1.2.8 Link Devices

Link devices are conceptual, in that they are used by the network, but not directly accessible by user programs. These devices enable network flexibility and expandability.

"RY" devices are used for transmission

"RX" devices are used for reception

Cyclic transmission between the master station and local stations, and between local stations

Master station (Station No. 0)

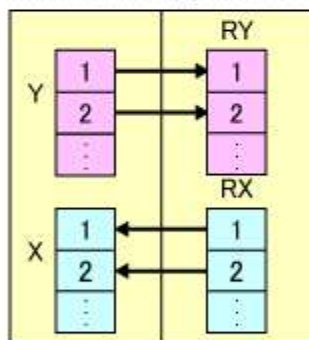

Features:
X and Y signals are switched for master-local communication so that the master station's outputs become inputs for local stations and the output signals of local stations become inputs for the master station.

Local station (Station No. 1)

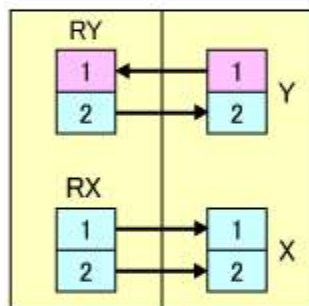

Local station (Station No. 2)

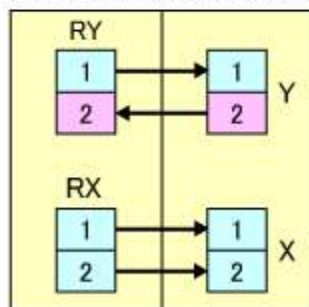

Send area
 Receive area

Transmission between the master station and local stations:

RY devices are used to send coil status information and become RX devices of the same number once reaching their destination.

RWw devices are used to send device value information and become RWr devices of the same number once reaching their destination.

Transmission between local stations:
RY devices are used to send coil status information remain RY devices of the same number once reaching their destination local station.

RWw devices are used to send device value information and remain RWr devices of the same number once reaching their destination.

1.2.8 Link Devices

The master station has a buffer memory area where it keeps the current status of all link devices for all stations.

For communication with remote I/O, the master station can address devices just as if they belonged to a local I/O module directly connected to the system.

Cyclic transmission between the master station and remote stations

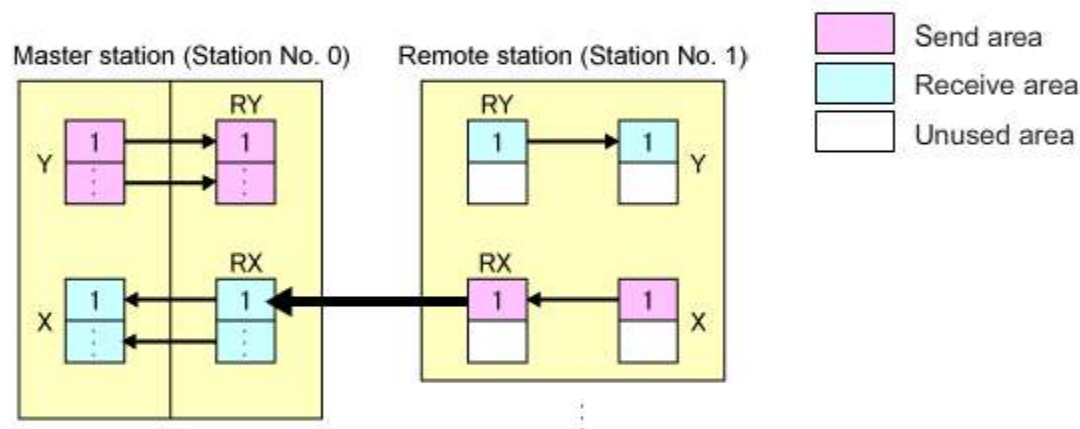

Features:

X and Y signals are NOT switched for master-remote communication. The master station's output signals become the remote station's outputs and the remote station's inputs become the master station's inputs.

- RY:** The RY value from the master station is sent to and becomes the RY output value of the remote station.
- RX:** The RX input value from the remote station is sent to and becomes the RX value of the master station.
- RWw:** (Remote Word write) The master station writes the value of its RWw device to the RWw device of the remote station.
- RWr:** (Remote Word read) The master station reads the value of the remote station's RWr device to its own RWr device.

1.2.9 Cyclic Transmission Example

Cyclic transmission by the master station and local stations

The CC-Link IE Field Network supports high-speed cyclic transmission; meaning that link device values are transferred to the appropriate stations in real time. The link devices from other stations may be used as if they were that station's own devices. The following example system uses this basic type of master-local communication.

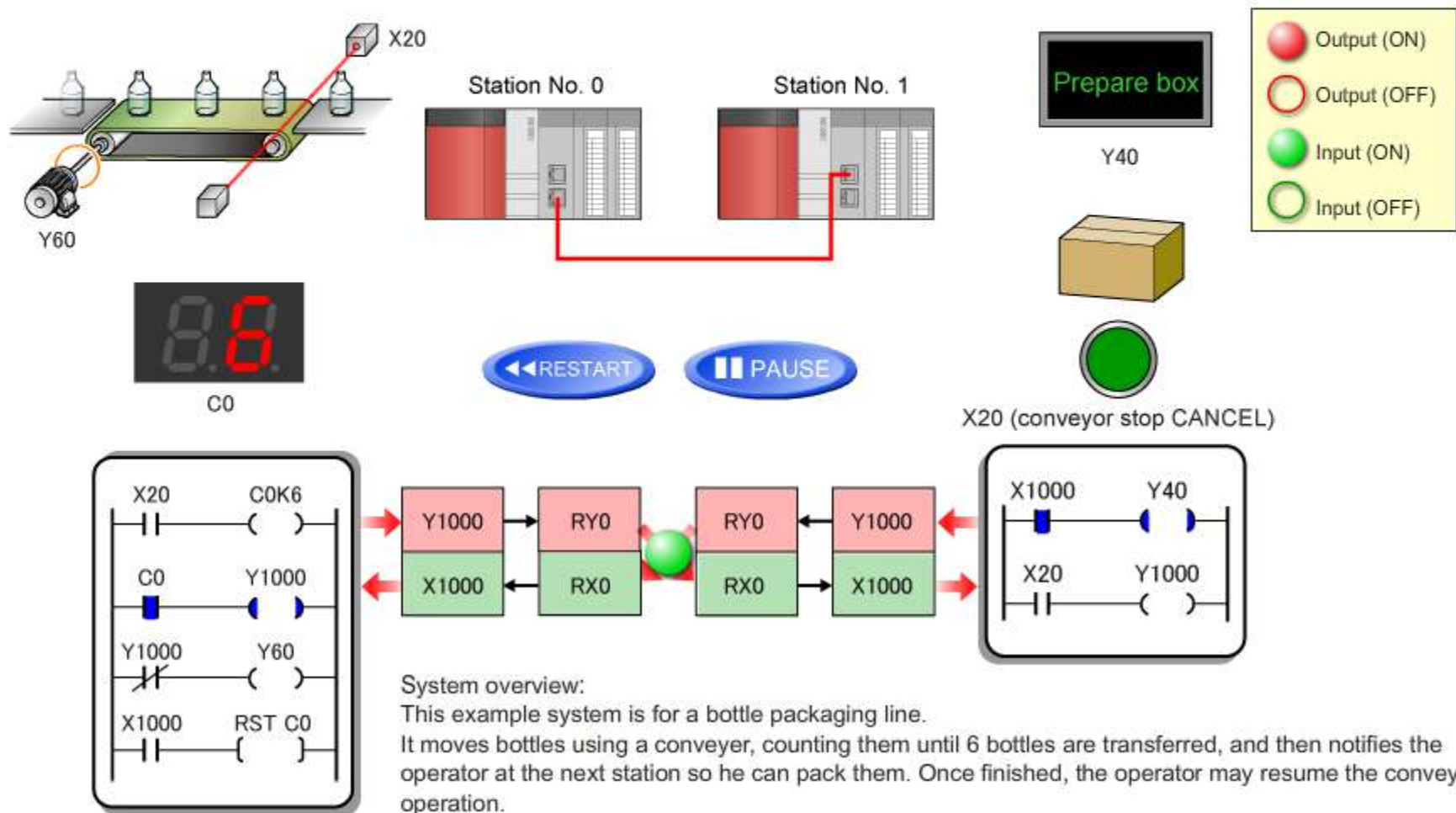

1.2.9 Cyclic Transmission Example

Cyclic transmission by the master station and local stations

The following example system uses cyclic transmission for basic type of master-local communication.

Confirm the interactive sample program operation by clicking on the ON/OFF switches

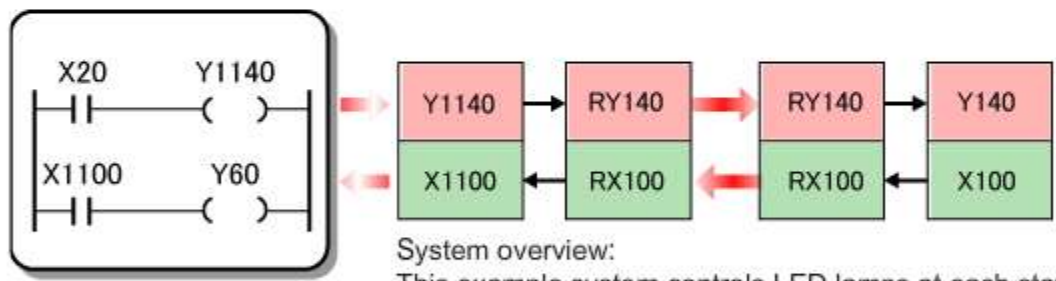
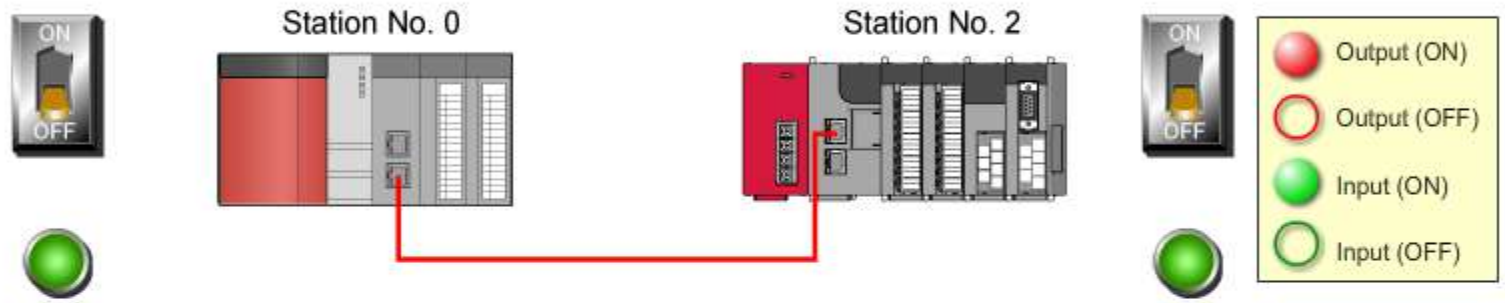

System overview:
 This example system controls LED lamps at each station to indicate the status of link registers.

Chapter 2 CC-Link IE Field Specifications and Configuration

This chapter will cover the system configuration, specifications, and settings of the CC-Link IE Field Network. Additionally, the end of this chapter contains an explanation about transmission delay time.

- 2.1 System Types
- 2.2 Specifications
- 2.3 Network Parameters



2.1 Station Types

There are several station types available depending on the purpose as was covered in the previous chapter. The three most basic station types are Master, Local, and Remote.

The master station contains the network settings and is typically set to station number 0. Station number settings are arbitrary so long as they are not duplicated.

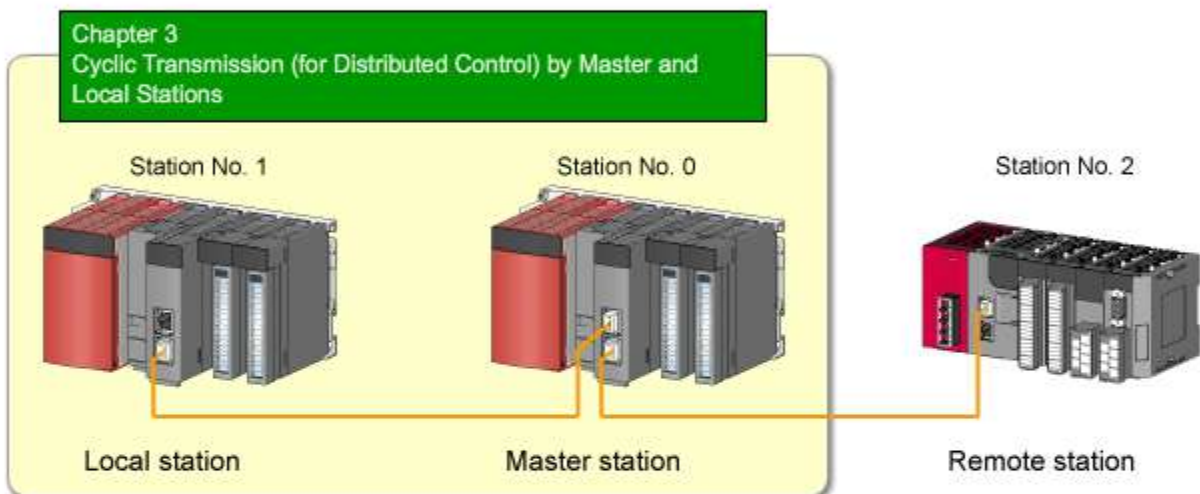

- **Master station**
Only one master station per network is allowed. This station contains the network settings for the rest of the network including the memory assignments necessary for using link devices.
- **Local station**
Local stations are intelligent function modules which are controlled by a programmable controller CPU. This gives local stations more functionality than remote I/O stations.
- **Remote station**
Remote stations do not have a control CPU, but take control of modules and I/O directly. Because they are not CPU modules themselves, they cannot execute user programs and rely on other networked stations for operation.

The CC-Link IE Field network is designed for use in general industries, how the following should be confirmed before constructing the network.

Item	Specification
Number of stations	The total number of eventual stations (both local and remote) should be estimated before construction. Refer to the "number of connected stations per network" specification. If the number exceeds this specification, consider dividing the network and using multiple master stations.
Number of link points	Estimate the number of I/O devices and registers which must be exchanged by the network. Ensure that the number does not exceed the specifications for "maximum number of link points" per station or network.
Physical configuration	Ensure the "maximum station-to-station distance" and "total cable length" specifications will not be exceeded. Determine the appropriate network topology (ring, star, line, etc.) by examining the location of stations, and the deciding how much fault tolerance is necessary.

How to divide a network into multiple networks is explained in the following section.

2.2

Basic Specifications

[Dividing a networks]

Network modules that are physically connected to one another by cable and whose communications are directed by a single master station are called a "network".

Networks may be divided for a number of reasons including a desire to separate network traffic, exceeded specifications, etc.

The following is an example of separate networks which can still communicate with each other.

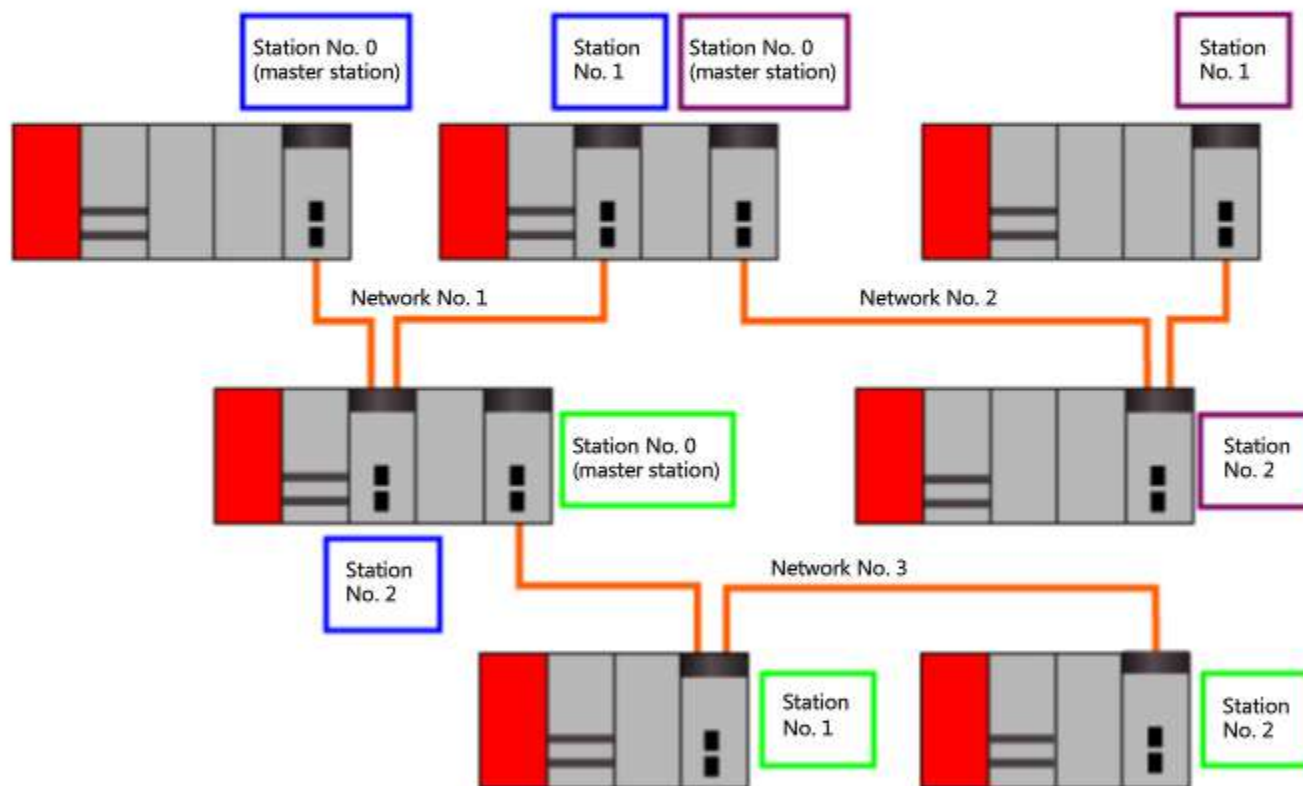

Groups of connected modules make up networks, as shown in the above figure.

To pass data from one network to another, a system with two network modules, called a relay station, is required. Splitting large networks into smaller ones can provide several benefits including reduced traffic (increased available bandwidth), faster link scan times, and improved reliability. When using separate networks, a failure on one network will usually be isolated from the other networks.

2.2.1 General Specifications

The following table lists the most important specifications of the CC-Link IE Field network.

Item	Specification
Maximum number of link points per network	Bit device: 16,384 points Word device: 8,192 points
Maximum number of link points per station	Bit device: 2,048 points Word device: 1,024 points
Maximum number of stations per network	120 stations excluding the master station
Maximum number of networks	239 networks
Maximum station-to-station distance	100m
Total cable length	Line topology: 12 km Star topology: Depends on the system configuration
Transmission cable	Double-shielded Ethernet cable, CAT (category) 5e or higher, straight cable

For more information, refer to the "CC-Link IE Field Network Master/Local Module User's Manual."

2.2.2

CC-Link IE Field Hardware

Master/local modules:

These modules are capable of functioning as either a local station or the master station, configurable via parameters. Use the mouse to hover over the following pictures and table to identify the corresponding part names.



CC-Link IE Field PCI Express board

Name	Function
LED indicator	These LEDs indicate the network and module/board status including the existence of errors.
CC-Link IE Field Network connector	The connection ports, P1 and P2 both provide the same functionality and either one may be used for connection. However, from the viewpoint of efficient installation work and wiring checks after installation, it is advisable to establish rules such as "Connect from P1 to P2."

2.2.2

CC-Link IE Field Hardware

L Series head module:

Station type: intelligent device station

These modules are used to configure a remote I/O network using L Series modules.

Use the mouse to hover over the following pictures and table to identify the corresponding part names.



Name	Function
LED indicator	These LEDs indicate the network and module status including the existence of errors.
CC-Link IE Field Network connector	The connection ports, P1 and P2 both provide the same functionality and either one may be used for connection. However, from the viewpoint of efficient installation work and wiring checks after installation, it is advisable to establish rules such as "Connect from P1 to P2."
USB connector	The USB connection is for connection of engineering tools such as GX Works2 for monitoring, diagnostics, and parameter configuration.

2.2.2

CC-Link IE Field Hardware



Cable name	Standard	Specifications
Ethernet cable	ANSI/TIA/EIA-568-B (Category 5e or higher) STP (double-shielded twisted pair)	Wire connection: Straight Connector: STP shielded 8P8C (RJ45) Cable length: Up to 100 m

The type of Ethernet cables typically found in retail stores are UTP (unshielded twisted pair). To ensure the network functions properly, follow the official specifications for cable type. Double shielded STP cables should be used to ensure safe operation in electrically noisy environments such as factories.

2.2.3 Transmission Delay Time

Transmission delay is the time it takes for a change in device value at one station to be reflected by a change in the corresponding device at another station. Systems that require precise synchronization need to take this delay time into account for the highest possible accuracy.

- CC-Link IE Field network transmission processing cycle

The following is an illustration of the transmission process for cyclic transmission on the CC-Link IE Field network. In this case station No. 0 is the master station, and is transmitting a change in value of a Y device to a local station where it is reflected by the corresponding X device.

Click the [Start] button to begin the explanation.

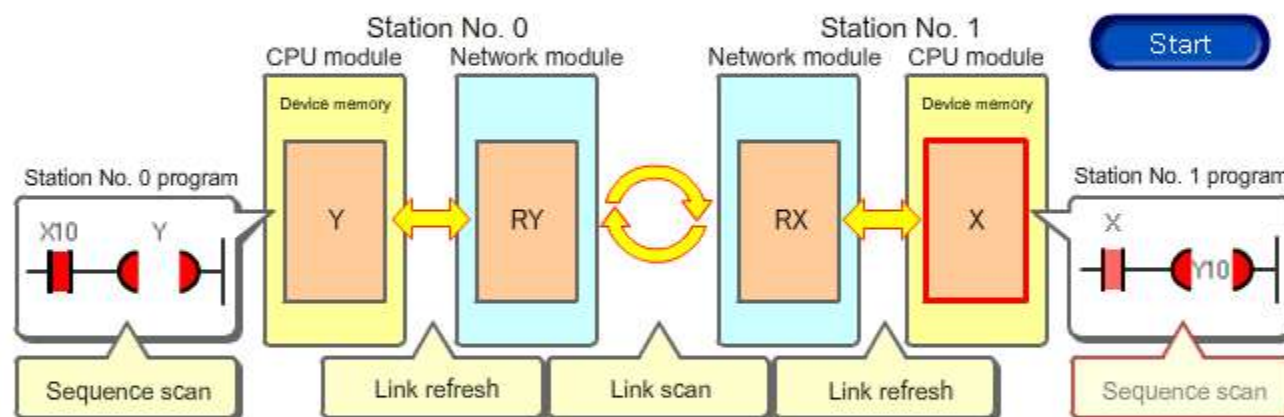

A user program in the master station (station No. 0) activates, or turns ON device "Y"

The Link refresh process reflects the change in value of device "Y" to the matching link device "RY" in the network module

During link scan, the value of RY is transferred over the network to the network module buffer memory of station No. 1 where it becomes link device "RX".

The Link refresh process reflects the change in value of link device "RX" to the matching device "X" in the CPU module

A user program in the CPU module of station No. 1 reads the status of device "X" as being active.

2.2.3 Transmission Delay Time

● Factors effecting transmission delay time

- Program scan time at send and receive stations
- Link refresh time
- Link scan time

● Potential problems

If transmission delay time becomes substantial, these types of problems may occur:

- Missing data
- Data arrives later than expected

● Countermeasures

- Divide the network into two or more smaller networks
- Upgrade to a faster controller CPU
- Optimize the number of link refresh points

● Formula

Refer to the CC-Link IE Field master/local module user's manual for details about transmission delay and a method to manually calculate the delay time.

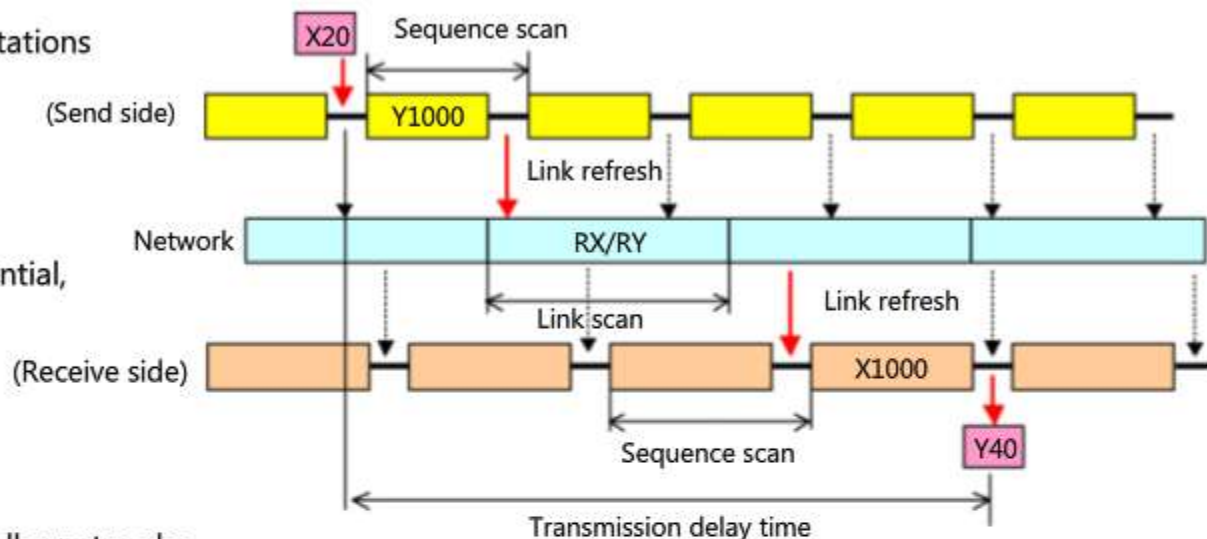

2.3

Network Parameters

Network parameters are chosen based on the requirements of the system and written to the network module using GX Works2.

The following table lists the minimum required settings for network operation

Setting item	Purpose and function of setting	Representative setting
Network Type	Set the network module function.	<ul style="list-style-type: none"> • CC-Link IE Field Network (master station) • CC-Link IE Field Network (local station)
Mode	Set the operation mode.	<ul style="list-style-type: none"> • Online, offline, hardware test, line test
Network Configuration Setting	Set the functions and the range of the send area for each station.	<ul style="list-style-type: none"> • Local station and intelligent device station • RS/RX and RY/RZ settings
Network Operation Setting	Set the I/O behavior in the case of program termination and network failure.	<ul style="list-style-type: none"> • Clear input data • Retain input data. • Retain output data • Clear output data.
Refresh Parameters	Set the assignment used when transferring a link device to a device of the programmable controller.	Example: <ul style="list-style-type: none"> • RX0000-01FF→X1000-11FF • RY0000-01FF→Y1800-19FF

Chapter 3 Cyclic Transmission (for Distributed Control) by Master and Local Stations

Chapter 3 focuses on the cyclic transmission method of communication (for distributed control). In this case, cyclic transmission takes place between the master station and local stations. Additionally, this chapter will cover the method of performing online verification.

Section 3.1: Starting Up the Subject System Hardware

Section 3.2: Checking the Subject System Specifications

Section 3.3: Setting the Subject System Network Parameters

Section 3.4: Sequence Program of the Subject System

Section 3.5: Troubleshooting the Subject System



3.1 Starting Up the Subject System Hardware

This section explains the steps necessary for creating and troubleshooting an example CC-Link IE Field Network system (the "subject system") using cyclic transmission.

3.1.1 Subject system configuration

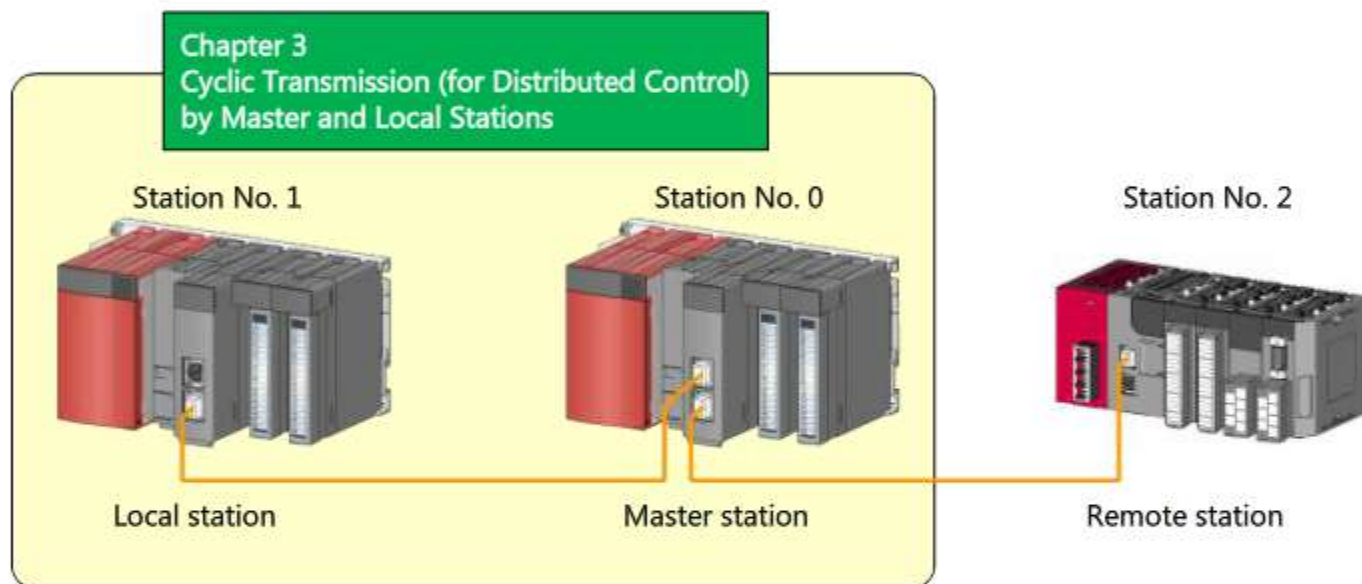

- Points**
- This example system includes one master station and one local station and will be configured for cyclic transmission to achieve distributed control.
 - The physical hardware of the master station and local station is the same, only the network parameters (software settings) are different.
 - The master station's station number is always 0.

3.2

Checking the Subject System Specifications

The specifications of the subject system are listed below.

Specification item	Description	
Topology	Ring	This topology is highly reliable because it uses two lines of wiring for communications.
Network module	QJ71GF11-T2	The Q-series CC-Link IE Field Network module can be used either as a local or master station according to the settings.
Link device assignment	Device areas accessible by local stations and Station No. 1 Bit device: RX/RX0-FF Word device: RWr/RWw0-FF	As shown in 1.1.8, the master station can access all areas for transmission and reception. Local stations can access allocated areas for transmission and reception. The send area of a local station is the receive area of the master station, and the send area of the master station is the receive area of the local station.

[Programmable controller module configuration]

The module configuration and I/O assignment of the subject programmable controller are shown below.

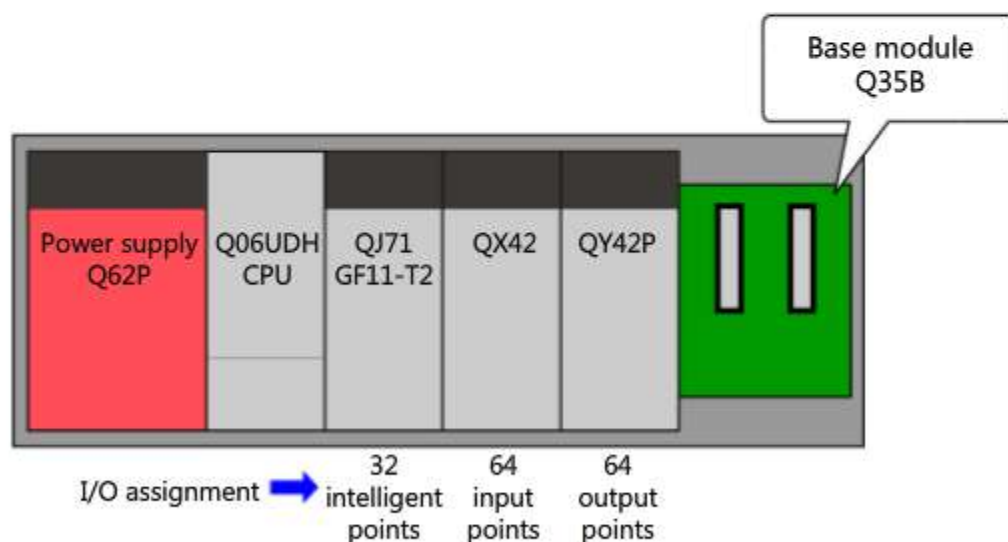

Link device assignment area

The "number of I/O points" in the programmable controller CPU specifications is the number of points that can be used by the modules installed on the base.

The "number of I/O device points" in the programmable controller CPU specifications indicates the range of devices available for networks including the CC-Link IE Field Network. These points are related to each other as follows: "Number of I/O device points" > "number of I/O points"

In the case of Q06UDH, X/Y0-FFF is the area "number of I/O points" available for the module; therefore, out of the total "number of I/O device points," the remaining range 1000-1FFF is not used by the module.

For this reason, the area 1000-1FFF is assigned to be used for 'link device refresh'.

3.2.1 Transmission cable connection

The Q-series CC-Link IE Field Network master/local module has two connection ports: P1 and P2. These two ports have the same function, so either one can be used for connection.

However, from the viewpoint of efficient installation work and wiring checks after installation, it is advisable to establish rules such as "Connect from P2 to P1."

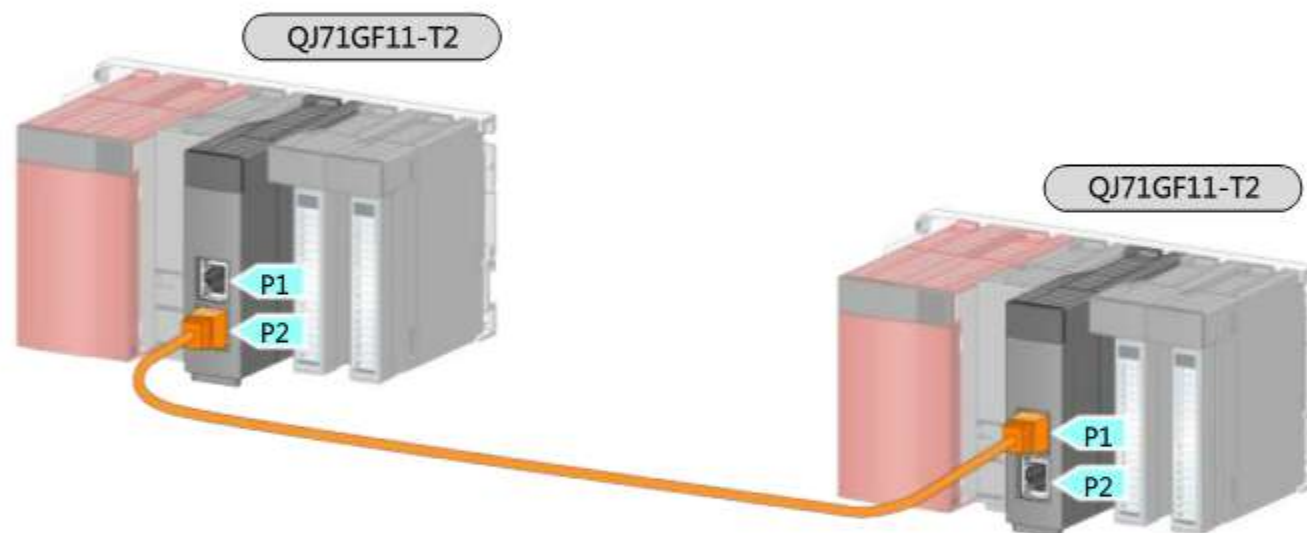

3.3 Setting the Subject System Network Parameters

This section explains how to set the network parameters using the GX Works2 screen simulation.

3.3.1 Setting the master station parameters

The master station parameters are set based on the configuration of the subject system.

Setting item	Purpose and function of setting	Setting
Network Type	Set the network module function.	<ul style="list-style-type: none"> • CC-Link IE Field Network (master station)
Mode	Set the operation mode.	<ul style="list-style-type: none"> • Online
Network Configuration Setting	Set the functions and the range of the send area for each station.	<ul style="list-style-type: none"> • Local station
Network Operation Setting	Set the I/O behavior in the case of program termination and network failure.	<ul style="list-style-type: none"> • Retain input data. • Retain output data.
Refresh Parameters	Set the assignment used when transferring a link device to a device of the programmable controller.	<ul style="list-style-type: none"> • Y1000-100F → RY0000-000F (16 points) • RX0000-000F → X1000-100F (16 points)

Cyclic transmission (for distributed control) by the master station and local stations

Master station (Station No. 0)

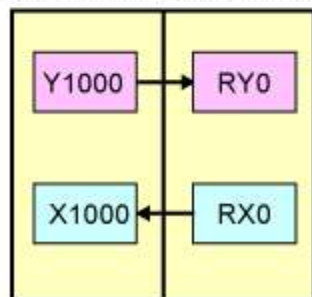

Local station (Station No. 1)

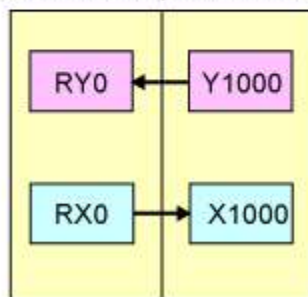

* The devices shown are limited to those specifically related to this course. In fact, the area should be specified in units of 16 points.

3.3.1

Setting the master station parameters

MELSOFT Series GX Works2 (Unset Project) - [[PRG] MAIN]

Project Edit Find/Replace Compile View Online Debug Diagnostics Tool Window Help

Navigation [PRG] MAIN

Project

- Parameter
 - PLC Parameter
 - Network Parameter
 - Ethernet / CC IE / ME
 - CC-Link
 - Remote Password
- Intelligent Function Module
- Global Device Comment
- Program Setting
- POU
 - Program
 - MAIN
 - Local Device Comment
- Device Memory
- Device Initial Value

Project

User Library

Connection Destination

English Unlabeled Q06UDH Host Station C NL

0

END

The settings are complete.
Click  to proceed.

3.3.2 Setting the local station network parameters

This section explains how to set the network parameters using the GX Works2 screen simulation. Review the settings before starting the simulation.

Setting item	Purpose and function of setting	Setting
Network Type	Set the network module function.	<ul style="list-style-type: none"> CC-Link IE Field Network (local station)
Mode	Set the operation mode.	<ul style="list-style-type: none"> Online
Network Operation Setting	Set the I/O behavior in the case of program termination and network failure.	<ul style="list-style-type: none"> Retain input data. Retain output data.
Refresh Parameters	Set the assignment used when transferring a link device to a device of the programmable controller.	<ul style="list-style-type: none"> Y1000-100F→RY0000-000F (16 points) RX0000-000F→X1000-100F (16 points)

Cyclic transmission (for distributed control) by the master station and local stations

Master station (Station No. 0)

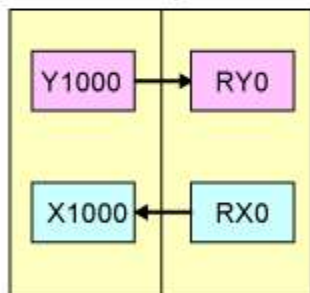

Local station (Station No. 1)

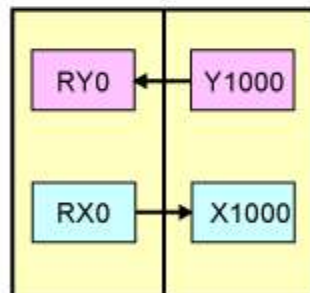

* The devices shown are limited to those specifically related to this course. In fact, the area should be specified in units of 16 points.

3.3.2

Setting the local station network parameters

MELSOFT Series GX Works2 (Unset Project) - [[PRG] MAIN]

Project Edit Find/Replace Compile View Online Debug Diagnostics Tool Window Help

Navigation [PRG] MAIN

Project

- Parameter
 - PLC Parameter
 - Network Parameter
 - Ethernet / CC IE / ME
 - CC-Link
 - Remote Password
- Intelligent Function Module
- Global Device Comment
- Program Setting
- POU
 - Program
 - MAIN
 - Local Device Comment
- Device Memory
- Device Initial Value

Project

User Library

Connection Destination

English Unlabeled Q06UDH Host Station C NL

The settings are complete.
Click  to proceed.

3.4 Sequence Program of the Subject System

This section explains how to create a sequence program for the master station and local stations of the subject system.

3.4.1 Sequence program

Here, you will create a sequence program that operates as follows.

Press the  button to confirm the operation.

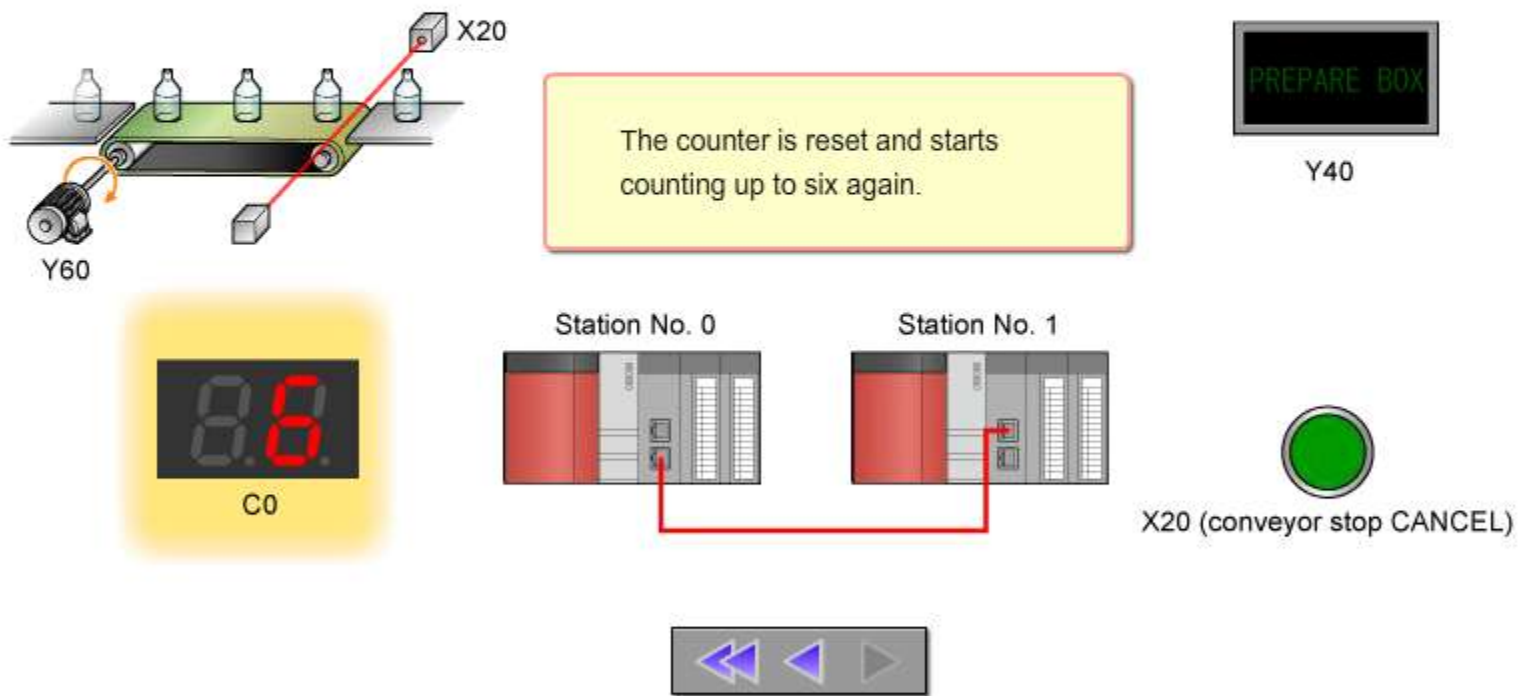

3.4.2 Subject system operation check

The status of the devices allocated to the network is automatically refreshed and transferred. Programming is also enabled for the transferred station without having to know the status of transmission operation for the network.

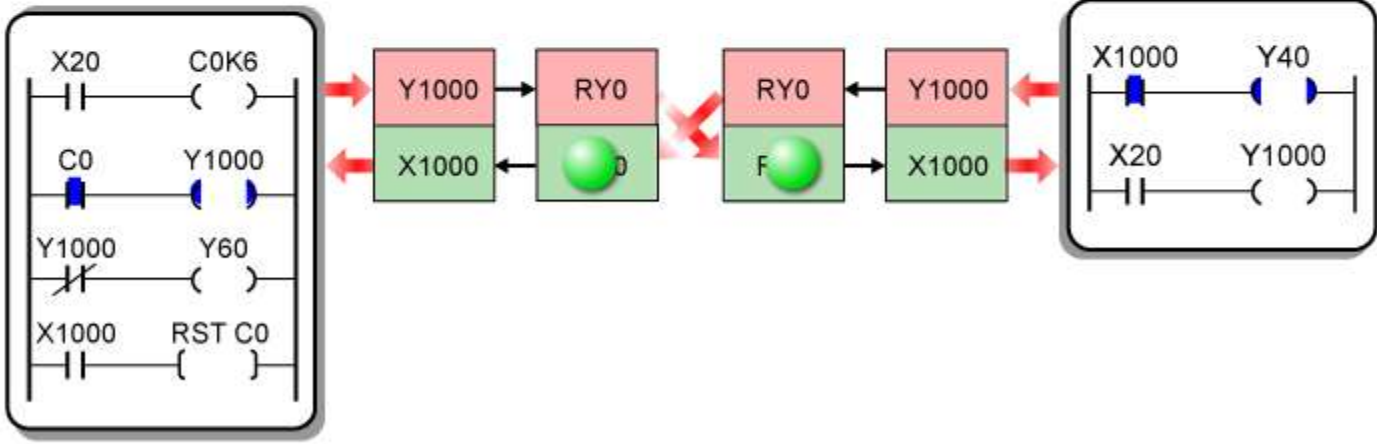
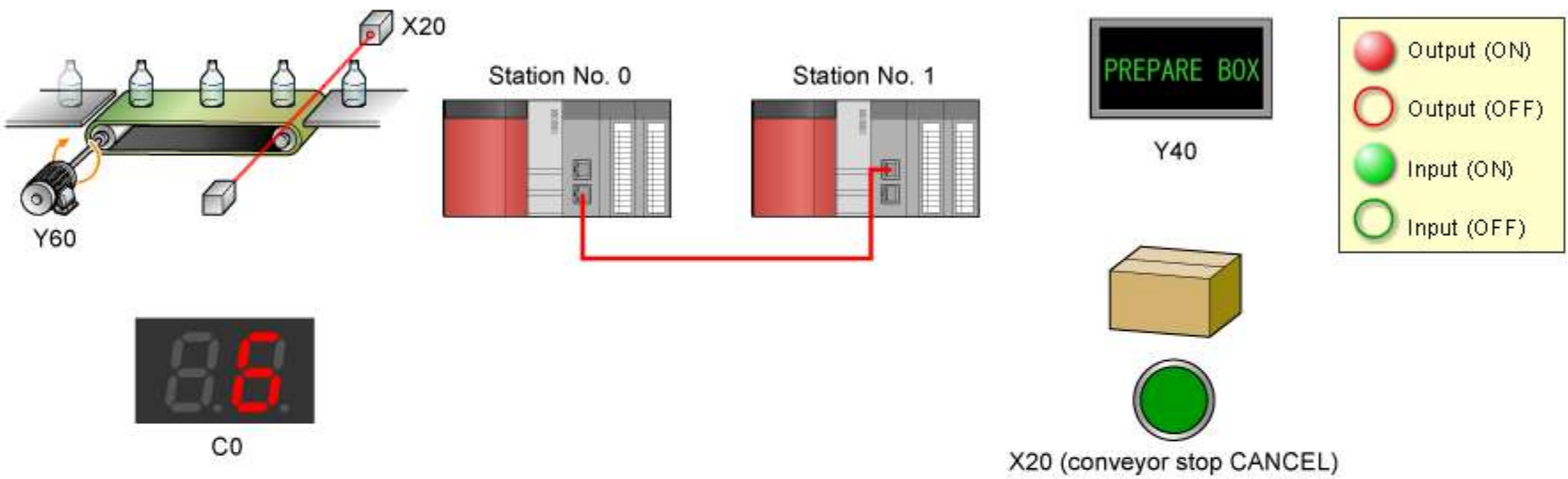

3.5

Troubleshooting the Subject System



The remainder of chapter 3 will focus on troubleshooting techniques (actions to be taken when the system is not operating as expected) and how to read programs from other stations over the network.

- Actions to take if the network is not operating properly
- How to read a sequence program via the network

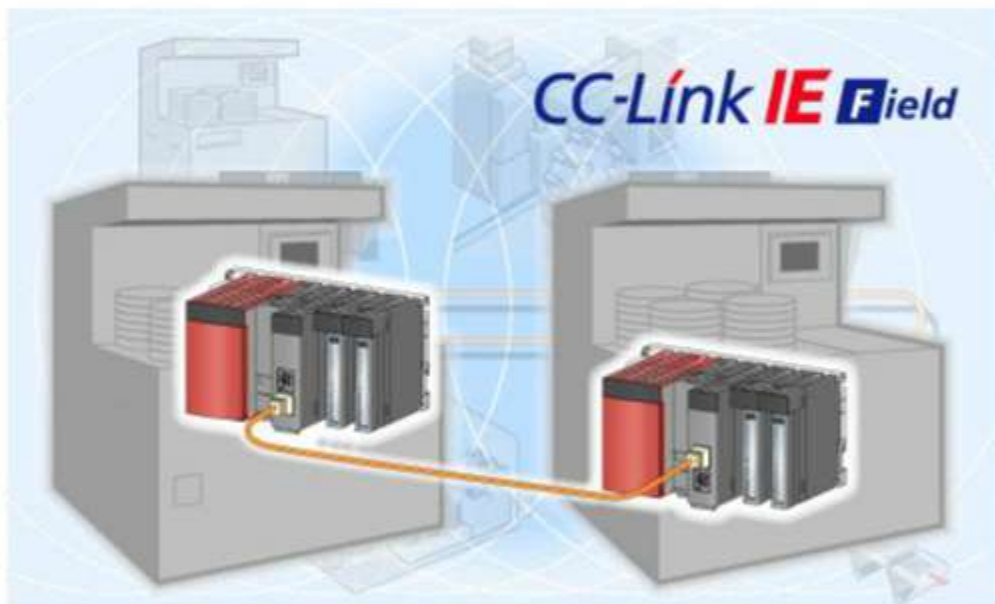

3.5.1

Action to be taken if the network is not operating

When the network is not operating as expected, the following steps should be taken to determine the cause and formulate corrective actions.

Is the CPU in "RUN" mode ?



Are the network module LEDs normal?



Run "Network Diagnostics" using GX Works2 to check the network status.

If the CPU is not in RUN mode, the issue is with the CPU, not the network module. Use GX Works2 to check the CPU error information and correct the problem.

Confirm the LED status of the network module (explained in section 3.5.2).

If the LED status indicates that there is a network error, use the network diagnostics function of GX Works2 to check the detailed error information and take corrective measures. (explained in section 3.5.3)

3.5.2

Checking the LED indications on the master station network module

Checking the module LEDs will provide basic information about the network status which can be very useful, especially when GX Works2 is not available to provide more detailed information.

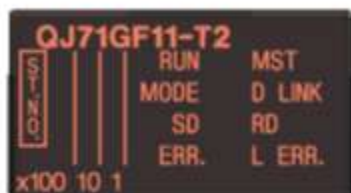

LED name	Function	Indication		Response to abnormality
		Normal	Abnormal	
RUN	Power is on and hardware is ready to operate.	On	Off	<ul style="list-style-type: none"> • Make sure that the power is turned on for the module. • Make sure that the module is correctly installed on the base module.
MODE	Indicates the operation mode, which is 'online' when lit.	On	Off or blinking	<ul style="list-style-type: none"> • Set it to 'online' mode using the network parameters.
D LINK	Communication is normal.	On	Off or blinking	<ul style="list-style-type: none"> • Eliminate the error cause of the programmable controller CPU. • Make sure that there is no error in the transmission path. (Cable length, outside the specifications, wire disconnection, switching hub, wrong route) • Check the status (error, stopped) of the communication partner. • Make sure that there is no duplicated station number.
ERR.	Error indication	Off	On	<ul style="list-style-type: none"> • Check for detailed information using GX Works2.
L ERR.	Link error indication	Off	On	<ul style="list-style-type: none"> • Make sure that there is no error in the transmission path. • Check the status (error, stopped) of the communication partner. • Set the master station to 'online' mode.

3.5.3**CC-Link IE Field Network diagnostics**

If the CC-Link IE Field Network does not seem to be operating normally, connect GX Works2, if available, to the programmable controller CPU and check for error information.

From the "Diagnostics" menu of GX Works2, select "System Monitor."

In addition to a problem in the network module, there are other factors that can stop the operation of the network module. It is important to check the error information and eliminate the error cause.

If the network module still does not operate even after the error causes are eliminated, select the master or local unit and then select "CC-Link IE Field Diagnostics."

The error state is displayed by an icon. Check the error information and then eliminate the error cause.

3.5.3

CC-Link IE Field Network diagnostics

CC IE Field Diagnostics

Select Diagnostics Destination

Module Module 1(Network No. 1)

Change Module...

Select Station

Station No. 1

Monitor Status



Monitoring

Start Monitor

Stop Monitor

Network Status

Total Slave Stations
(Set In Parameter)

1

Total Slave Stations
(Connected)

1

Current Link
Scan Time

1

ms

Number of Station
Errors Detected

0

Legend...

Connected Station

Master:0

Local:1

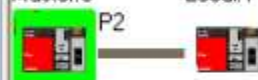

Operation Test

Communication Test...

Check the transient communication route from the connected station to the destination station.

Cable Test...

Check the cable status between the connected station and the destination station.

Link Start/Stop...

Start or stop the network data link.

Selected Station Communication Status Monitor

Station No. 0 No Error

Mode: Online (Normal Mode)

MAC Address:08-00-70-B1-CB-EF

Information Confirmation/Set

Network Event History...

Access the network the event history log.

Reserved Station
Function Enable...

View reserved station numbers and temporarily enable reserved stations.

Enable / Disable
Ignore Station Errors...

View station numbers set to ignore errors and temporarily ignore station errors.

As shown, you can recognize error information easily, visually in the CC IE Field Diagnostics window and can take action quickly.

Click  to proceed.



3.6

Connection to Other Stations Using GX Works2

This section explains how to access another station via the CC-Link IE Field Network using GX Works2.

With GX Works2 connected to the programmable controller in the CC-Link IE Field Network, you can access the programmable controller in another station connected to the network in order to transfer and monitor programs.

Transient transmission is performed during connection to other stations using GX Works2. Transient transmission is executed between cyclic transmissions.

Using GX Works2 for connection to other stations, you can check the status of a programmable controller CPU connected to a control panel far from the one near you, and therefore you need not go all the way to where the target CPU is installed.

Here, you will operate the training machine to access the programmable controller in Station No. 1.

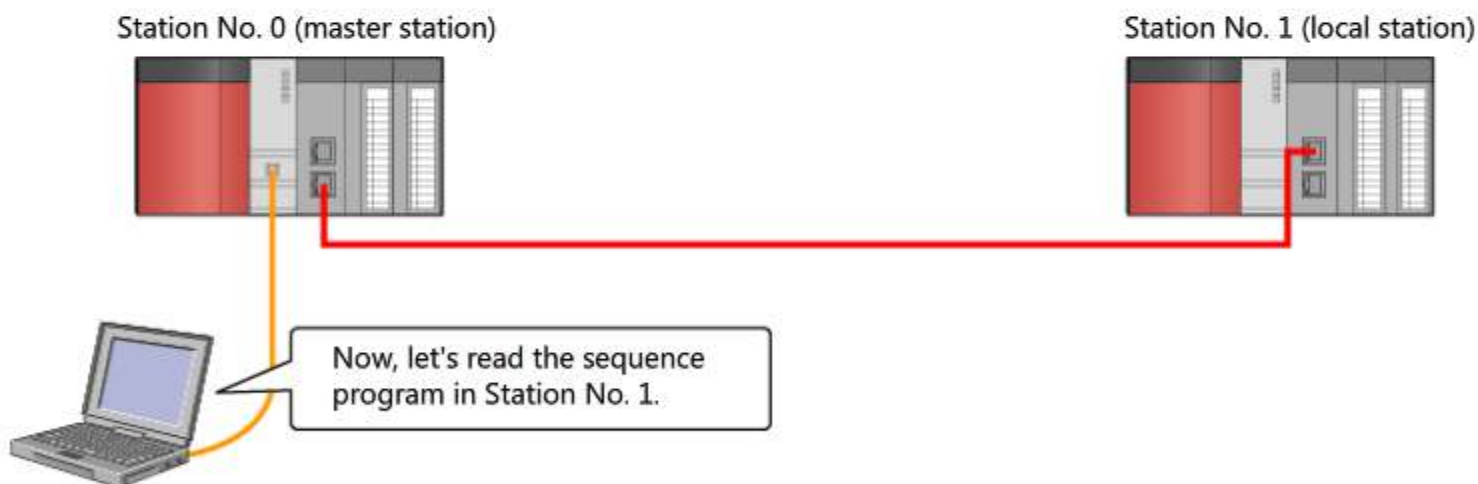

3.6.1**Reading programs from other stations**

Here, you will learn how to use GX Works2, which is connected to Station No. 0 (master station), to read the sequence program from the programmable controller in Station No. 1 (local station) via the CC-Link IE Field Network.

Now, you will perform an operation using the GX Works2 screen simulation.

3.6.1

Reading programs from other stations

The screenshot displays the MELSOFT Series GX Works2 software interface. The main window shows a ladder logic program for the 'MAIN' project. The program consists of three rungs:

- Rung 0: A normally open contact labeled 'X0' is connected to output coil 'Y40'.
- Rung 1: A normally open contact labeled 'X1100' is connected to output coil 'Y1140'.
- Rung 4: A terminal symbol labeled '[END]' is connected to the right rail.

The left sidebar shows the project structure, including 'Parameter', 'Intelligent Function Module', 'Global Device Comment', 'Program Setting', 'POU', 'Program', 'MAIN', 'Local Device Comment', 'Device Memory', and 'Device Initial Value'. The bottom status bar indicates the language is 'English', the project is 'Unlabeled', and the connection destination is 'Q20UDH CC IE Field-1-1'.

The sequence program read from another station is displayed. This completes reading the program from another station and operating the monitor.

Click  to proceed.

Chapter 4 Cyclic Transmission (for Remote I/O Control) by Master and Remote Stations

Chapter 4 focuses on the cyclic transmission method of communication (for remote I/O control). In this case, cyclic transmission takes place between the master station and a remote I/O station. Information about diagnostics, troubleshooting, and program verification is also covered.

Section 4.1: Starting Up the Subject System Hardware

Section 4.2: Checking the Subject System Specifications

Section 4.3: Setting the Subject System Network Parameters

Section 4.4: Sequence Program of the Subject System

Section 4.5: Troubleshooting the Subject System



4.1

Starting Up the Subject System Hardware

This section explains the steps necessary for creating and troubleshooting an example CC-Link IE Field Network system (the "subject system") using cyclic transmission.

4.1

Subject system configuration

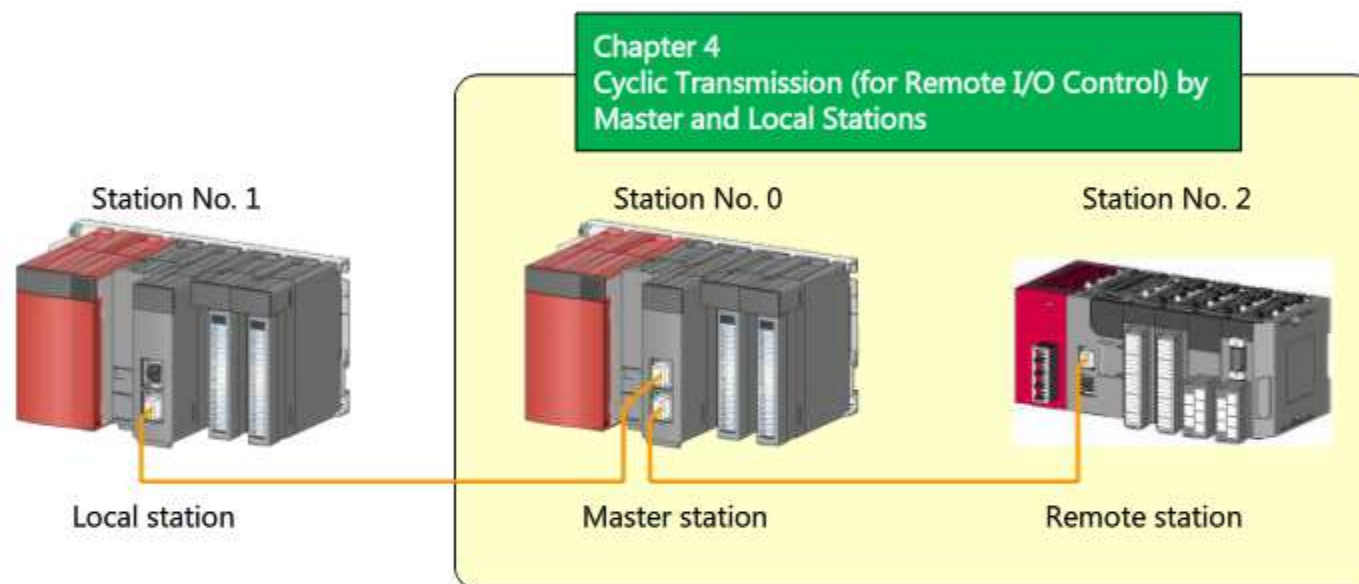

Points

This example system includes one master station and one remote station and will be configured for cyclic transmission to achieve remote I/O control.

The remote station does not have a CPU module, but instead uses a "head module". It contains configuration information but no user program.

The master station's station number is always 0.

4.2

Checking the Subject System Specifications

The table below lists specifications for the CC-Link IE Field Network L Series head module as used in the example "subject system".

[Head module specifications]

Specification item	Specifications	Description
Topology	Ring	Improved reliability due to each station being connected with two other stations.
Network module	LJ72GF15-T2	The remote station "head module" is used in place of a CPU module.
Link device assignment	Device areas accessible by remote stations and Station No. 2: Bit device: RY140-14F→Y40-4F RX100-10F←X0-F	As shown in 1.1.8, the master station can access all areas for transmission and reception. Remote stations can access allocated areas for transmission and reception. The send area of a remote station is the receive area of the master station, and the send area of the master station is the receive area of the remote station.

[Master station specifications related to remote I/O]

Specification item	Specifications
Number of I/O points	Up to 4,096 X and Y device points may be used for physical I/O.
Device	Bit devices: X, Y; Word device: W; Other devices: SB, SW, SM, SD

(1) (2) (3) (4) (5)

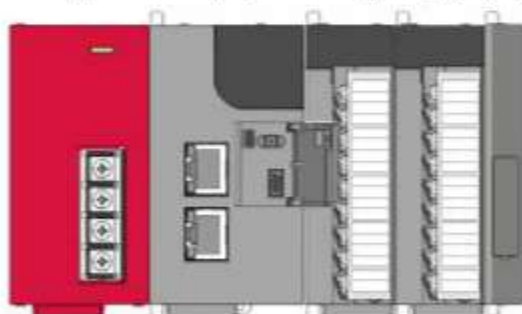

[Remote station modules configuration of subject system]

No.	Module type	Module model name	Module specifications
(1)	Power supply module	L61P	Input: 100 to 240 V AC, Output: 5 V DC, 5 A
(2)	Head module	LJ72GF15-T2	Remote station module
(3)	Input module	LX42C4	64 DC input points (X0 – 3F)
(4)	Output module	LY42NT1P	64 transistor output points (Y40 – 7F)
(5)	End cover	L6EC	Attached to the right end of the L-series system (mandatory)

4.2.1 Transmission cable connection

A CC-Link IE Field Network module has two connection ports: P1 and P2. These two ports have the same function, so either one can be used for connection.

However, from the viewpoint of efficient installation work and wiring checks after installation, it is advisable to establish rules such as "Connect from P2 to P1."

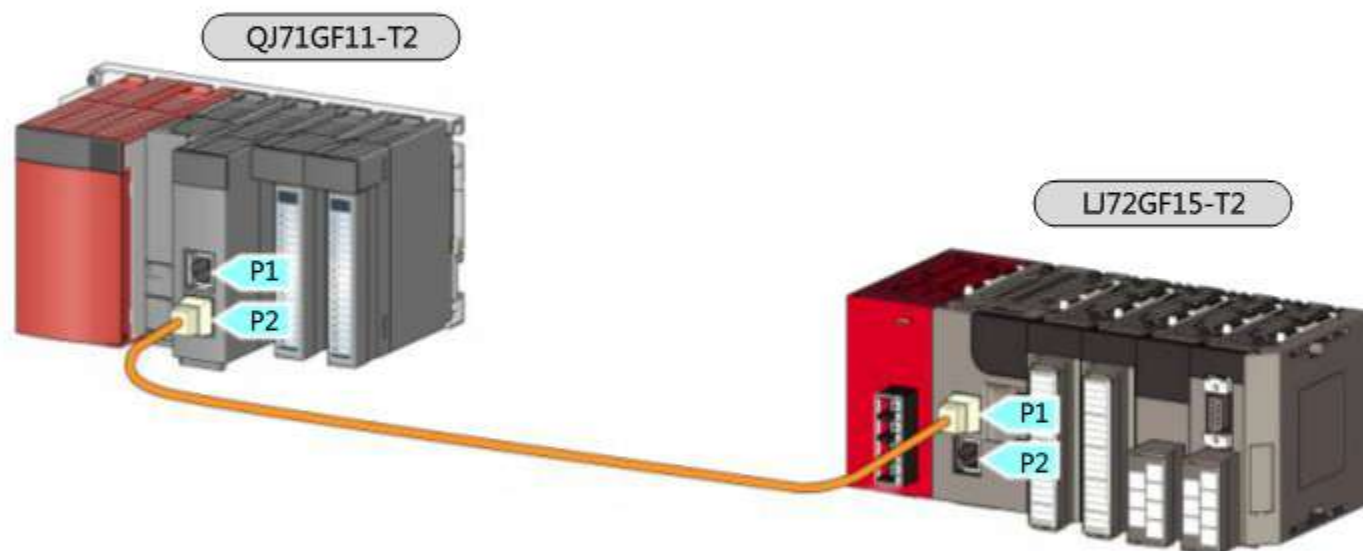

4.3 Setting the Subject System Network Parameters

This section explains how to set the network parameters using the GX Works2 screen simulation.

4.3.1 Setting the master station parameters

The master station parameters are set based on the configuration of the subject system.

Setting item	Purpose and function of setting	Setting
Network Type	Set the network module function.	• CC-Link IE Field Network (master station)
Mode	Set the operation mode.	• Online
Network Configuration Setting	Set the functions and the range of the send area for each station.	• Intelligent device station
Network Operation Setting	Set the I/O behavior in the case of program termination and network failure.	• Retain input data. • Retain output data.
Refresh Parameters	Set the assignment used when transferring a link device to a device of the programmable controller.	• Y1140-114F→RY140-14F (16 points) • X1100-110F←RY100-10F (16 points)

Cyclic transmission (for remote I/O control) by master and remote stations

Master station (Station No. 0)

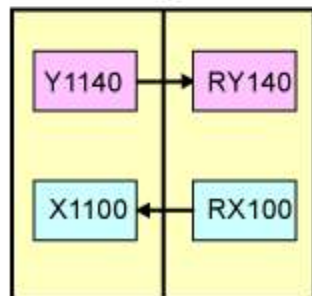

Remote station (Station No. 2)

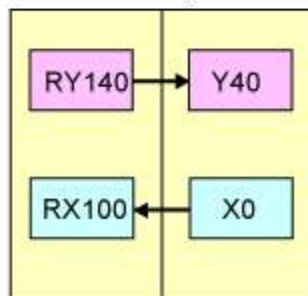

* The devices shown are limited to those specifically related to this course. In fact, the area should be specified in units of 16 points.

4.3.1 Setting the master station parameters

MELSOFT Series GX Works2 (Unset Project) - [[PRG] MAIN]

Project Edit Find/Replace Compile View Online Debug Diagnostics Tool Window Help

Navigation [PRG] MAIN

Project

- Parameter
 - PLC Parameter
 - Network Parameter
 - Ethernet / CC IE / ME
 - CC-Link
 - Remote Password
- Intelligent Function Module
- Global Device Comment
- Program Setting
- POU
 - Program
 - MAIN
 - Local Device Comment
- Device Memory
- Device Initial Value

Project

User Library

Connection Destination

English Unlabeled Q06UDH Host Station C NL

0 [] [END]

The settings are complete.
Click  to proceed.

4.3.2

Setting the remote station network parameters

This section explains how to set the network parameters using the GX Works2 screen simulation. Review the settings before starting the simulation.

Setting item	Purpose and function of setting	Setting
Network Type	Set the network module function.	<ul style="list-style-type: none"> • CC-Link IE Field Network (local station)
Mode	Set the operation mode.	<ul style="list-style-type: none"> • Online
Network Operation Setting	Set the I/O behavior in the case of program termination and network failure.	<ul style="list-style-type: none"> • Retain input data. • Retain output data.
Refresh Parameters	Set the assignment used when transferring a link device to a device of the programmable controller.	<ul style="list-style-type: none"> • Y1000-100F→RY0000-000F (16 points) • RX0000-000F→X1000-100F (16 points)

Cyclic transmission (for remote I/O control) by master and remote stations

Master station (Station No. 0)

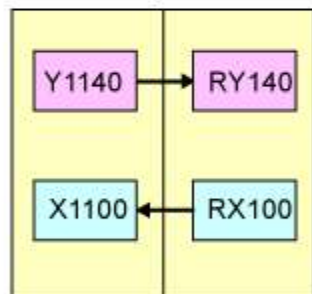

Remote station (Station No. 2)

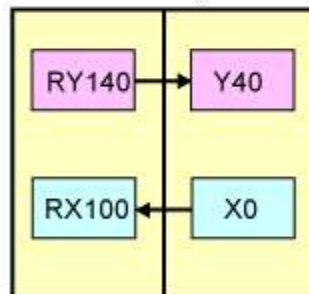

* The devices shown are limited to those specifically related to this course. In fact, the area should be specified in units of 16 points.

4.3.2

Setting the remote station network parameters

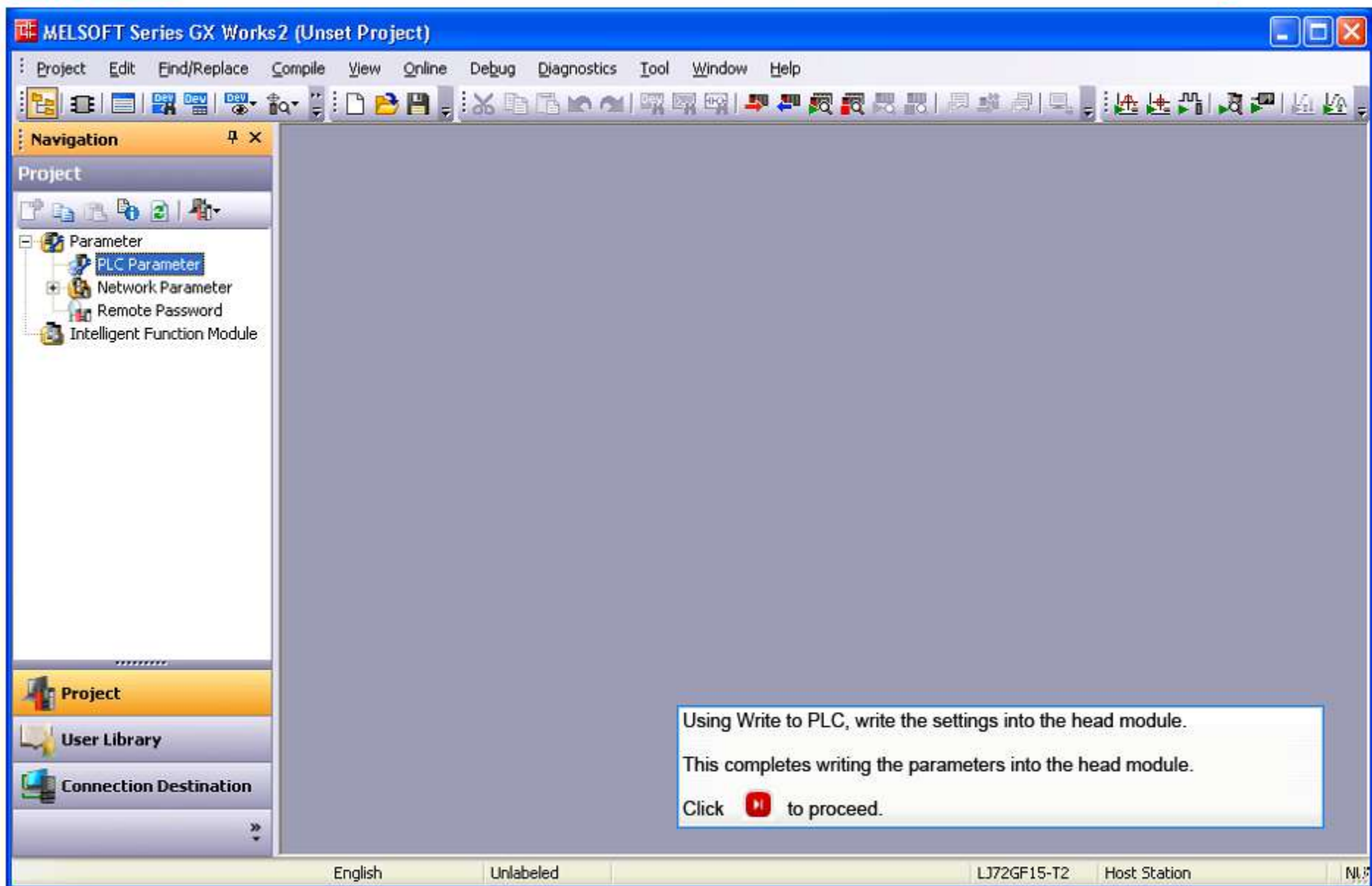

The screenshot shows the MELSOFT Series GX Works2 software interface. The title bar reads "MELSOFT Series GX Works2 (Unset Project)". The menu bar includes Project, Edit, Find/Replace, Compile, View, Online, Debug, Diagnostics, Tool, Window, and Help. The toolbar contains various icons for file operations and project management. The left-hand "Navigation" pane is expanded to show the "Project" tree, with "PLC Parameter" selected. Below the navigation pane are tabs for "Project", "User Library", and "Connection Destination". The main workspace is currently empty. A text box in the lower right of the workspace contains the following instructions:

Using Write to PLC, write the settings into the head module.
This completes writing the parameters into the head module.
Click  to proceed.

At the bottom of the window, the status bar shows "English", "Unlabeled", "LJ72GF15-T2", "Host Station", and "NL".

4.4 Sequence Program of the Subject System

Here, you will create a sequence program for the master station of the subject system.

4.4.1 Sequence program

This system turns on the lamp of the other station.

Press the  button to confirm the operation.

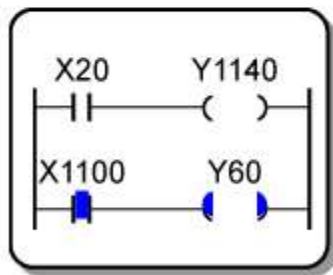
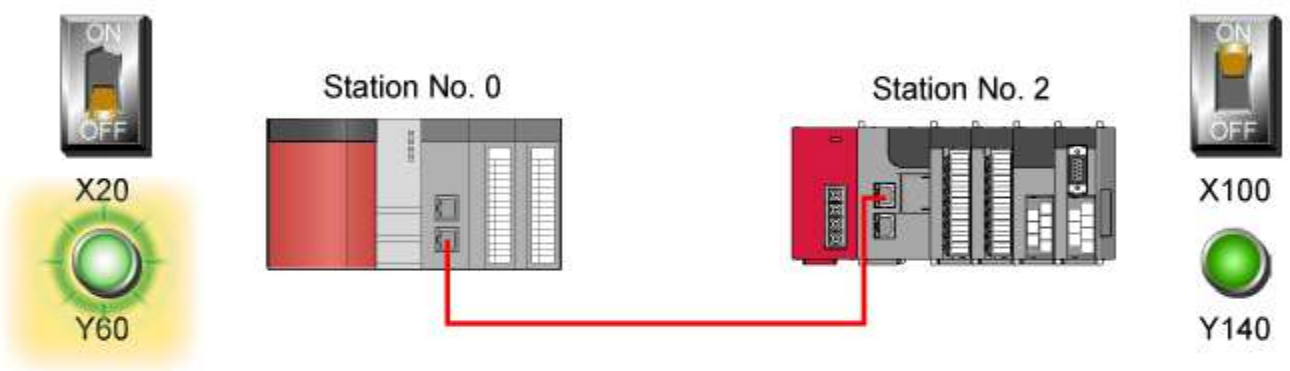

- Station No. 0
- Station No. 2
- (5) Operator turns ON the X100 switch of Station No. 2.
- (6) The status is transferred via the network.
- (7) Sequence program turns Y60 ON.
- (8) Lamp Y60 turns ON.



4.4.2 Subject system operation check

An I/O device connected to the head module from the programmable controller CPU is handled as if it were connected to the base module.
 An I/O device assigned to the remote station is automatically refreshed and transferred.

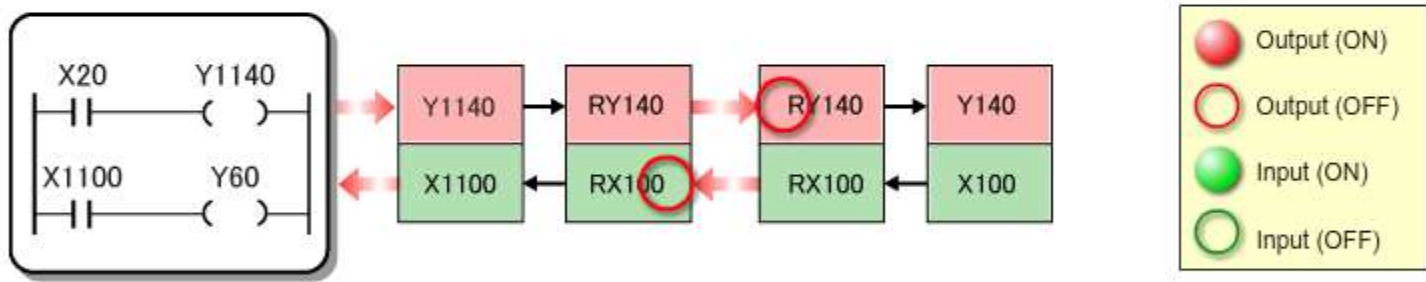

4.5

Troubleshooting the Subject System

The remainder of chapter 4 will focus on troubleshooting techniques (actions to be taken when the system is not operating as expected) and how to read programs from other stations over the network.

- Actions to take if the network is not operating properly
- How to read a sequence program via the network

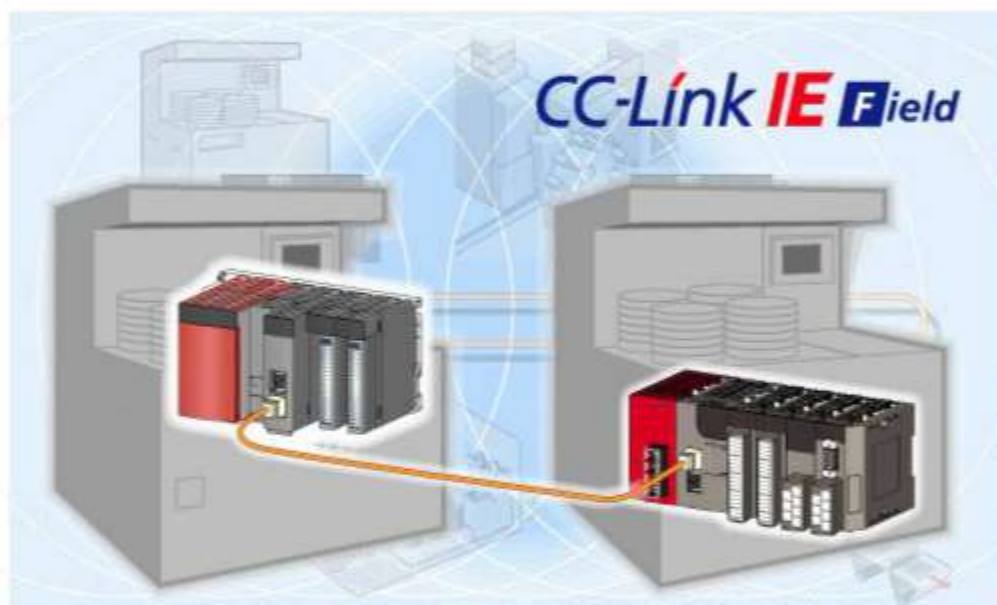

4.5.1

Action to be taken if the network is not operating

When the network is not operating as expected, the following steps should be taken to determine the cause and formulate corrective actions.

Is the CPU in "RUN" mode?



Are the network module LEDs normal?



Run "Network Diagnostics" using GX Works2 to check the network status.

If the CPU is not in RUN mode, the issue is with the CPU, not the network module. Use GX Works2 to check the CPU error information and correct the problem.

Confirm the LED status of the network module (explained in section 4.5.2).

If the LED status indicates that there is a network error, use the network diagnostics function of GX Works2 to check the detailed error information and take corrective measures. (explained in section 4.5.3)

4.5.2

Checking the LED indications on a remote station network module

Checking the module LEDs will provide basic information about the network status which can be very useful, especially when GX Works2 is not available to provide more detailed information.

```

LJ72GF15-T2
RUN  MODE  SD  ERR.
REM. D LINK RD LERR.
-----
STATION NO.
1
2
4
8
x100 x10 x1

```

LED name	Function	Indication		Response to abnormality
		Normal	Abnormal	
RUN	Power is on and hardware is ready to operate.	On	Off	<ul style="list-style-type: none"> Make sure that the power is turned on for the module. Make sure that the module is correctly installed on the power supply module.
MODE	Indicates the operation mode, which is 'online' when lit.	On	Off or blinking	<ul style="list-style-type: none"> Set it to 'online' mode using the network parameters.
D LINK	Communication is normal.	On	Off or blinking	<ul style="list-style-type: none"> Make sure that there is no error in the transmission path. (Cable length, outside the specifications, wire disconnection, switching hub, wrong route) Check the status (error, stopped) of the communication partner. Make sure that there is no duplicated station number.
ERR.	Error indication	Off	On	<ul style="list-style-type: none"> Check for detailed information using GX Works2.
L ERR.	Link error indication	Off	On	<ul style="list-style-type: none"> Make sure that there is no error in the transmission path. Check the status (error, stopped) of the communication partner. Set the master station to 'online' mode.

4.5.3

CC-Link IE Field Networks diagnostics

If the CC-Link IE Field Network does not seem to be operating normally, connect to the module and check for error information using GX Works2.

From the "Diagnostics" menu of GX Works2, select "System Monitor."

In addition to a problem in the network module, there are other factors that can stop the operation of the network module. It is important to check the error information and eliminate the error cause.

If the network module still does not operate even after the error causes are eliminated, select the master or local unit and then select "CC-Link IE Field Diagnostics."

The error state is displayed by an icon. Check the error information and then eliminate the error cause.

4.5.3

CC-Link IE Field Networks diagnostics



CC IE Field Diagnostics

Select Diagnostics Destination

Module Module 1(Network No. 1)

Change Module...

Select Station

Station No.0

Monitor Status



Monitoring

Start Monitor

Stop Monitor

Network Status

Total Slave Stations
(Set In Parameter)

1

Total Slave Stations
(Connected)

1

Current Link
Scan Time

1

ms

Number of Station
Errors Detected

0

Legend...

Connected Station

Master:0

Intelli2



Operation Test

Communication Test...

Check the transient communication route from the connected station to the destination station.

Cable Test...

Check the cable status between the connected station and the destination station.

Link Start/Stop...

Start or stop the network data link.

Information Confirmation/Set

Network Event History...

Access the network the event history log.

Reserved Station
Function Enable...

View reserved station numbers and temporarily enable reserved stations.

Enable / Disable
Ignore Station Errors...

View station numbers set to ignore errors and temporarily ignore station errors.

Selected Station Communication Status Monitor

Station No. 0 No Error

Mode: Online (Normal Mode)

MAC Address:08-00-70-B1-CB-EF

As shown, you can recognize error information easily, visually in the CC IE Field Diagnostics window and can take action quickly.

Click  to proceed.



4.6

Connection to Other Stations Using GX Works2

In this section, you will learn how to access another station via the CC-Link IE Field Network using GX Works2.

With GX Works2 connected to the programmable controller in the CC-Link IE Field Network, you can access the programmable controller in another station connected to the network in order to transfer and monitor programs.

Here, you will perform an operation that prompts Station No. 2 to access the programmable controller of Station No. 0. This process uses the transient transmission mode briefly explained in Section 3.6. Transient transmission is executed between cyclic transmissions.

Using this method allows you to check the status of a programmable controller CPU connected to the control panel far from the one near you, and therefore you do not have to go all the way to where the target CPU is installed.

Station No. 0 (master station)

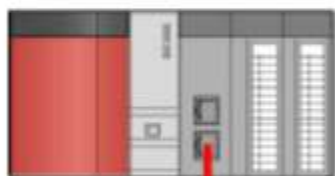

Station No. 2 (remote station)

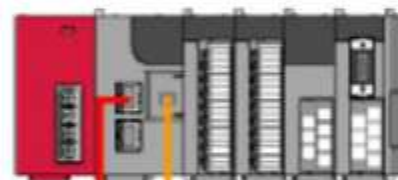

Now, let's read the sequence program in Station No. 0.

4.6.1

Reading programs from other stations

Here, you will learn how to use GX Works2, which is connected to Station No. 2 (remote station), to read the sequence program from the programmable controller in Station No. 0 (master station) via the CC-Link IE Field Network.

Next, you will perform an operation using the GX Works2 screen simulation.

4.6.1

Reading programs from other stations

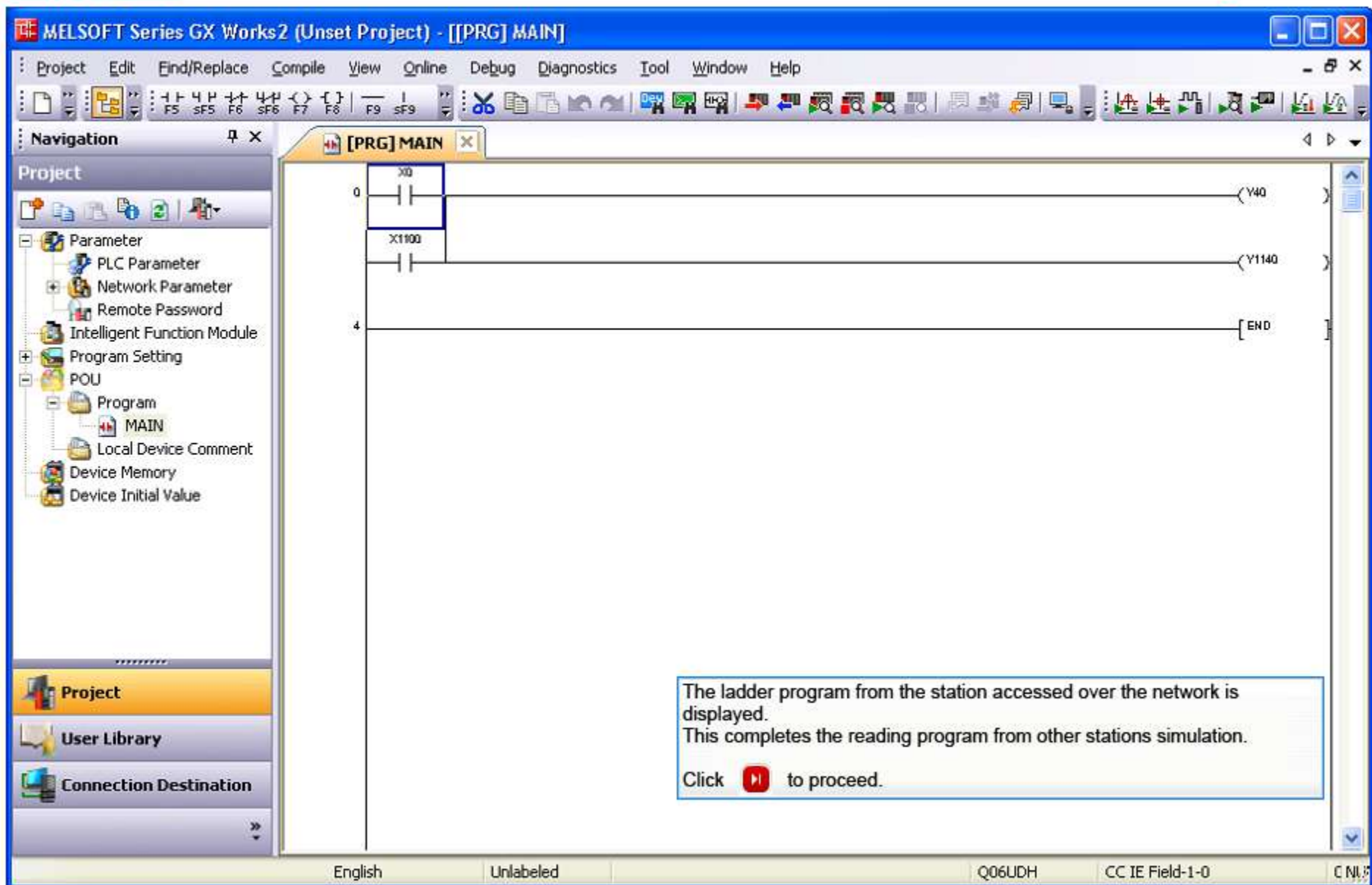

MELSOFT Series GX Works2 (Unset Project) - [[PRG] MAIN]

Project Edit Find/Replace Compile View Online Debug Diagnostics Tool Window Help

Navigation [PRG] MAIN

Project

- Parameter
 - PLC Parameter
 - Network Parameter
 - Remote Password
 - Intelligent Function Module
- Program Setting
- POU
 - Program
 - MAIN
 - Local Device Comment
- Device Memory
- Device Initial Value

Project

User Library

Connection Destination

English Unlabeled Q06UDH CC IE Field-1-0 C NL

The ladder program from the station accessed over the network is displayed.
This completes the reading program from other stations simulation.
Click  to proceed.

Now that you have completed all of the lessons of the **PLC CC-Link IE Field Network** Course, you are ready to take the final test. If you are unclear on any of the topics covered, please take this opportunity to review those topics.

There are a total of 5 questions (11 items) in this Final Test.

You can take the final test as many times as you like.

How to score the test

After selecting the answer, make sure to click the **Answer** button. Your answer will be lost if you proceed without clicking the Answer button. (Regarded as unanswered question.)

Score results

The number of correct answers, the number of questions, the percentage of correct answers, and the pass/fail result will appear on the score page.

Correct Answers : 2

Total Questions : 9

Percentage : 22%

To pass the test, you have to answer **60%** of the questions correct.

Proceed

Review

Retry

- Click the **Proceed** button to exit the test.
- Click the **Review** button to review the test. (Correct answer check)
- Click the **Retry** button to retake the test again.

The differences between the CC-Link IE Controller Network and CC-Link IE Field Network are summarized in the following table.

Choose which combination explains which type of network.

	--Select--	--Select--
Feature	Large Capacity, High Reliability, Long Distance	Flexible wiring topology, multipurpose network
Distribution usage	Distributed control	Distributed control, remote I/O control
Communication media	Optical fiber cable: Expensive and requires skill for cabling High noise tolerance	Twisted paired cable: Less expensive and relatively easy cabling
Topology	Ring: Featuring higher reliability than dual loop	Star, line, and ring: Featuring a high degree of freedom for cabling
Number of device points	Word: 128k points; Bit: 32k points	Word: 16k points; Bit: 32k points
Fault tolerance	Control station transition: Operating even when the control station fails	-
Interstation cable distance	550m	100m
Total extension	550 (m) × 120 (maximum number of connected stations) = 66 (km)	Line topology: 100 (m) × 120 (maximum number of connected stations) = 12 (km)

Test Final Test 2

The animation below shows the method of transferring device values over the network using cyclic transmission in a distributed control context (master station & local station) and a remote I/O context (master station & remote I/O station). Select the appropriate network configuration to match the device value transfer method.

Q1

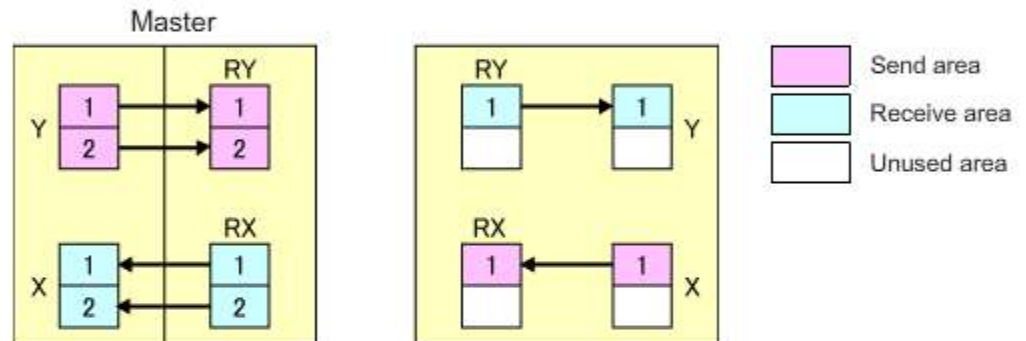

Q2

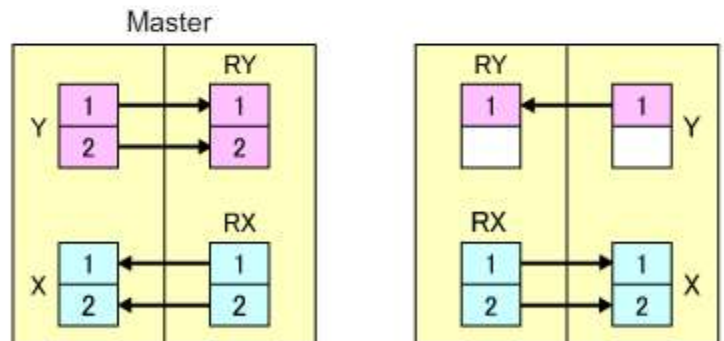

The following table summarizes the features of cyclic transmission (for distributed control) by the master station and local stations of the CC-Link IE Field Network and cyclic transmission (for remote I/O control) by the master station and remote stations.

Choose which feature explains which network type.

System configuration	Description
<input type="text" value="--Select--"/>	Information is exchanged between programmable controller systems. Connecting distributed devices (controllers) via a network improves the flexibility, expandability, and maintainability of the automation system.
<input type="text" value="--Select--"/>	This configuration eliminates the problems of extending I/O lines resulting inconvenient, thick bundles of wiring. Additionally, only one sequence program in one CPU is required which helps to make troubleshooting easier and reduce costs.

[Answer](#)[Back](#)

The following table summarizes the features of the two communication modes, cyclic transmission and transient transmission, used in the CC-Link IE Field Network.



Choose which feature explains which mode of data communication.

Mode	Overview of data communications	Send/receive program
<input type="text" value="--Select--"/>	The data in the area specified in advance by the network parameter is periodically sent and received automatically.	Unnecessary (Data is sent and received according to the specified network parameters.)
<input type="text" value="--Select--"/>	Data is sent and received only when a communication request is made between programmable controllers within the network.	Necessary (Data is sent and received by a program according to dedicated instructions.)

[Answer](#)[Back](#)

Test Final Test 5

The following table summarizes the features of the topologies used in the CC-Link IE Field Network. Choose which feature explains which type of topology.

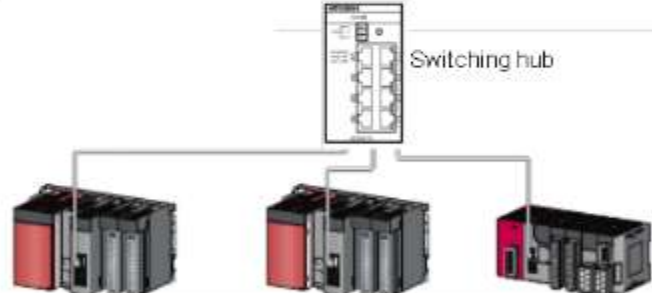
<p>--Select--</p>		<ul style="list-style-type: none"> • Cabling is relatively compact. • Cable disconnection is not likely to cause a failure of the entire system.
<p>--Select--</p>		<ul style="list-style-type: none"> • Cabling is not bulky. • Cable disconnection leads to a failure of the entire system.
<p>--Select--</p>	 <p style="text-align: center;">Switching hub</p>	<ul style="list-style-type: none"> • Cable disconnection is not likely to cause a failure of the entire system. • Cascade connection of switching hubs is possible. • Can be used with a line topology. • Cables are concentrated in one place.

Answer

Back

You have completed the Final Test. Your results are as follows.
To end the Final Test, proceed to the next page.

Correct answers : 0

Total questions : 5

Percentage : 0%

Proceed

Review

Retry

You failed the test.

You have completed the **PLC CC-Link IE Field Network** Course.

Thank you for taking this course.

We hope you enjoyed the lessons and the information you acquired in this course will be useful in the future.

You can review the course as many times as you want.

Review

Close