

# PLC CC-Link

This training course (e-learning) is designed for those who will construct an FA field network or a CC-Link system for the first time.

## Introduction Purpose of the Course

This course provides training for users who will use CC-Link for the first time and actually configure CC-Link data link systems using a programmable controller (PLC). The course includes the following:

- Basic knowledge
- Fundamental structure of the data link
- Basic parameter settings per system configuration
- Programming method
- System start-up
- Operation check

In this course, the CC-Link system setup procedure is explained along with the configuration of the system for practice.

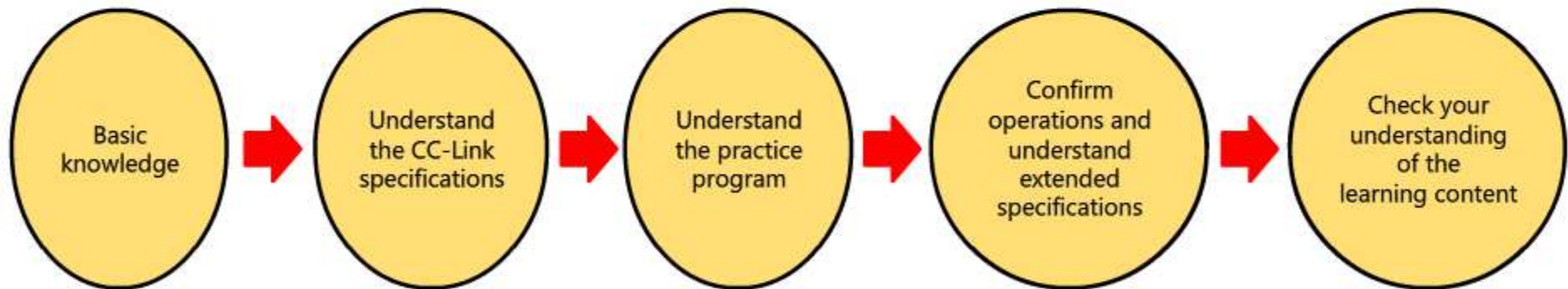

## Introduction Course Structure

The contents of this course are as follows.  
We recommend that you start from Chapter 1.

### Chapter 1 Overview of CC-Link

Learn the features and basic configuration of the CC-Link system.

### Chapter 2 Specifications and Settings

Learn the basics of how to configure CC-Link systems, including the specifications, basic terms, and basic command settings of CC-Link systems.

### Chapter 3 Launching the Remote I/O System

Learn the settings and operations necessary for launching the remote I/O system.

### Chapter 4 Expandability and Reliability of CC-Link

This chapter describes how to utilize operations other than remote I/O learned in this course. It also explains about the configuration for improving the reliability of the systems.

### Final Test

Passing grade: 60% and higher

## Introduction How to Use This e-Learning Tool



|                           |  |   |
|---------------------------|--|---|
| Go to the next page       |  | Go to the next page.  |
| Back to the previous page |  | Back to the previous page.  |
| Move to the desired page  |  | "Table of Contents" will be displayed, enabling you to navigate to the desired page.    |
| Exit the learning         |  | Exit the learning.<br>Window such as "Contents" screen and the learning will be closed. |

## Introduction **CC-Link Specifications**

The latest version as of December 2012 is Ver. 2., which is expanded in functionality from Ver. 1.1. This course uses CC-Link Ver. 1.1 for explanation in order to understand its fundamentals.

See the manual for details of the specifications of Ver. 2.

## Introduction **Cautions for Use**

### **Safety precautions**

When you learn by using actual products, please carefully read the safety precautions in the corresponding manuals.

### **Precautions in this course**

- The displayed screens of the software version that you use may differ from those in this course.

## Chapter 1 Overview of CC-Link

This course describes the basics of CC-Link, which is a type of field network. The course is intended for users who have completed the "FA Equipment for Beginners (Industrial Network)" course or who have an equivalent level of knowledge.

### The role of CC-Link

CC-Link is an abbreviation of Control & Communication Link. Its purpose is to **integrate system control and communication**.

CC-Link is **an open network**. Its specifications have been disclosed widely to vendors of sensors and valves to be used in FA environments.

It is possible to configure your system according to its purpose by assembling the products of many participating vendors (partner manufacturers).

### Background of why FA networks are required

Nowadays, large-scale, integrated systems are required in order to fulfill the demands of modern streamlined systems.

Networking of various devices are a **prerequisite for communicating and sharing information** in such factory automation (FA) environments.

1.1 Necessity of FA Networks

1.2 CC-Link Family and the Position of CC-Link

1.3 Features of CC-Link

1.4 Two Data Communication Methods

1.5 Types of Components

1.6 Configuration of CC-Link

1.7 Relationship between Remote I/O and Programmable Controller CPU Devices

1.8 Summary of this Chapter

## 1.1

## Necessity of FA Networks

Before beginning the main topic, we'd like to review FA networks.  
FA networks are used for two purposes as follows.

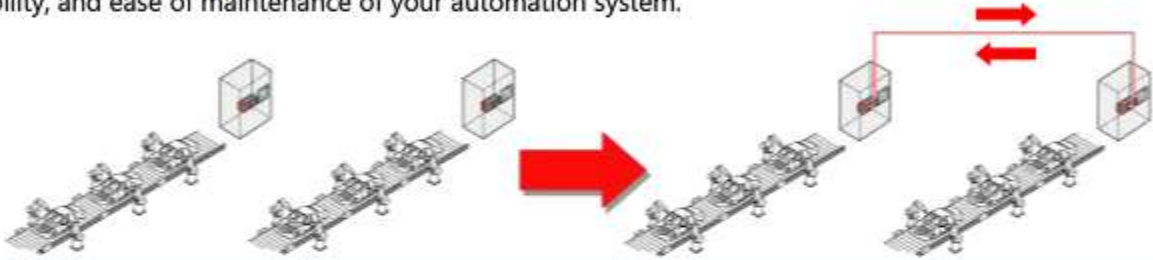
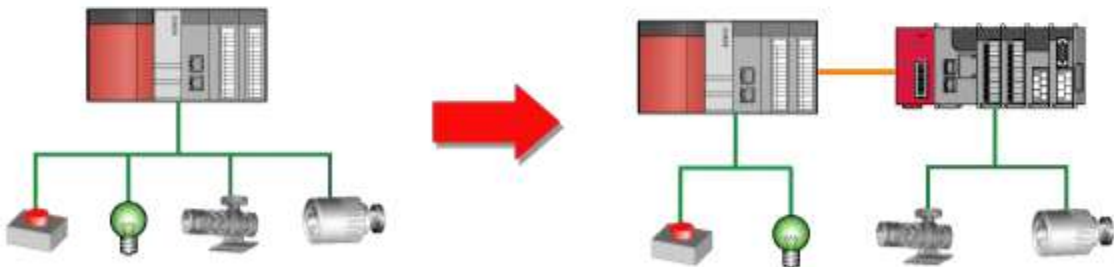
| Purpose of networking  | Description   |
|--|---|
| <p><b>Information sharing</b><br/>(Cyclic transmission between the master station and local stations)</p>          | <p>Information is shared within the programmable controller system.<br/>By connecting the distributed devices (controllers) through a network, you are able to improve the flexibility, expandability, and ease of maintenance of your automation system.</p>   |
| <p><b>Distribution of I/O devices</b><br/>(Cyclic transmission between the master station and remote stations)</p> | <p>Not only may you encounter trouble by simply extending the I/O lines, you may also require extra area for bundling thick I/O lines.<br/>To solve this, you can use distributed I/O systems to transfer the I/O status through a network without wiring I/O lines.<br/>By storing sequence programs in a single programmable controller CPU, you are able to configure your desired systems in a cost-effective manner from which you are able to find failed sections quickly.</p>  |

CC-Link supports both purposes. This course describes the most basic distributed I/O arrangement using CC-Link.



The following table shows the differences in each product in the CC-Link family.

| Type                  | Features  | Speed               | Wiring                |
|-----------------------|---|---------------------|-----------------------|
| CC-Link IE Controller | High speed and reliability (resistant to noise and disturbance)                             | 1 Gbps*1            | Optical fiber         |
| CC-Link IE Field      | High speed, <b>flexible wiring</b>  | 1 Gbps*1            | Multiple topologies*2 |
| CC-Link               | Relatively-inexpensive system configuration, <b>a variety of proven connectable devices</b> | 156 kbps to 10 Mbps | Bus connection*3      |

\*1 1 Gbps:

Transfers  $1 \times 10^9$  bits per second.

\*2 Topology:

This indicates how the wiring is configured. The more flexible the topology, **the more you are allowed to make complicated wiring and system layouts.**

\*3 Bus connection:

A method of connection by which all modules are gathered in a single signal line.

CC-Link has the following features:

- **Proven performance** used for many years by many users
- Remote I/O systems **can be configured in a relatively inexpensive manner.**
- CC-Link-compatible **I/O devices, sensors, valves, and actuators made by partner manufacturers<sup>\*1</sup> can be combined with the system.**
- Distributed control through the communication between the controllers<sup>\*2</sup>
- Punctuality in the network communication period<sup>\*3</sup>
- Extensive RAS<sup>\*4</sup> function

\*1 Partner manufacturers:

Vendor companies of sensors, actuators, and other equipment who participate in the CC-Link Partner Association (CLPA).

\*2 Distributed control:

Different to the centralized control in which one programmable controller CPU performs all control. Programmable controller CPUs are distributed according to the contents of control.

\*3 Punctuality:

Responses are returned at fixed periods.

\*4 RAS:

An abbreviation of Reliability, Availability, and Serviceability. This is an index for stable, secure, and reliable operation.

## 1.4 Two Data Communication Methods

The following two data communication methods are used for programmable controller networks.

- Cyclic transmission
- Transient transmission

The table shown below identifies their differences and advantages.

| Method                 | Overview of data communication   | Program for sending/receiving data  |
|------------------------|--|---|
| Cyclic transmission    | Cyclically and automatically sends/receives the data in the areas specified in advance by network parameters <sup>*1</sup> .     | Not necessary<br>(Sends/receives data based on the settings of network parameters.)           |
| Transient transmission | Sends/receives data in between cyclic transmissions, only when there is a request for communication between PLCs in the network. | Necessary<br>(Sends/receives data based on the programs to which special commands are given.) |

CC-Link supports both cyclic and transient transmissions.

In this course, **the basic FA network transmission, cyclic transmission, is used.**

**\*1 Network parameters:**

These are used for setting networks. The configuration of the devices to be connected, as well as the actions to be taken by the devices on both of the network and programmable controller CPUs can be set.

## 1.5 Types of Components

A CC-Link system consists of the following four devices.

There may be discrepancies in the locations where the devices are used and their transmission methods, depending on the type of station. Therefore, it is necessary to select required slave stations\*1 according to your purpose.

**You need to take into account the types of stations for setting network parameters later.**

### Type of station used in CC-Link

| Type of station |                            | Description  | Location  |
|-----------------|----------------------------|--|---|
| Master station  |                            | Manages and controls the data link system.<br>Possesses the network control information (network parameters). One station is required per system.  | <b>On the base</b>                                    |
| Slave station   | Local station              | Communicates with the master station and other local stations.<br>The module is identical with that for the master station, but becomes a local station as the settings differ.                      | <b>On the base</b>                                    |
|                 | Intelligent device station | Carries out cyclic and transient transmissions.<br>Local stations are also regarded as intelligent device stations.  | <b>Separated from the programmable controller CPU</b> |
|                 | Remote station             | Includes a remote I/O station (handles bit data) and a remote device station (handles bit data and word data).<br>Carries out cyclic transmissions only. No transient transmissions are taken place. | <b>Separated from the programmable controller CPU</b> |

In this course, you will learn **how to control remote I/O using master and remote stations.**

\*1 Slave station:  
Stations other than the master station are called slave stations.

## 1.6

## Configuration of CC-Link

## CC-Link system configuration example

Each device is wired as shown below.

Terminating resistors are necessary on both ends of the wiring in order to stabilize the signals.

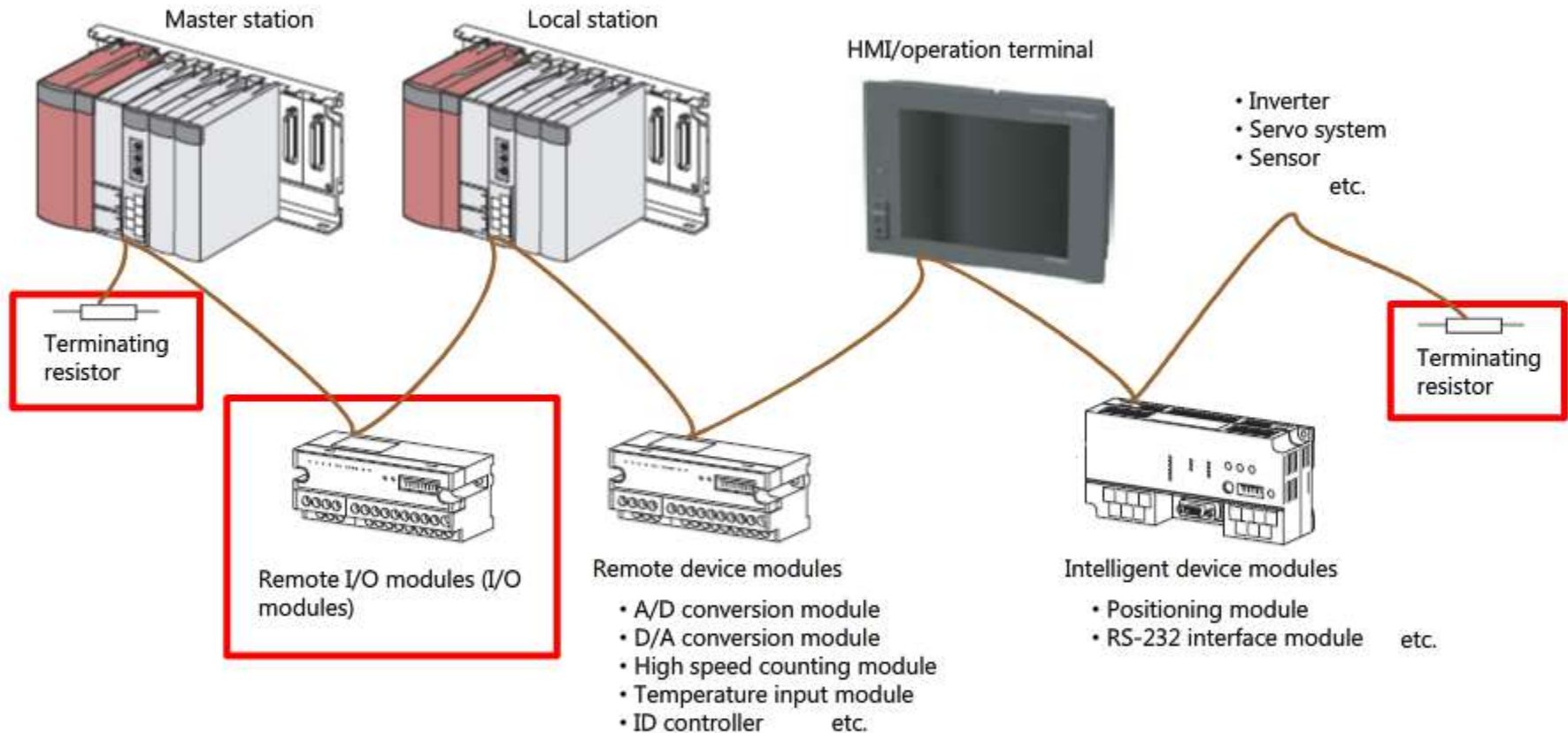

CC-Link allows various devices to be connected as shown in the above figure. This course describes the controls using the most basic remote I/O module.

## 1.7 Relationship between Remote I/O Devices and the Programmable Controller CPU Devices

### Communication of remote I/O stations

- Bit information (ON/OFF) is transmitted using remote input devices (RX) and remote output devices (RY).
- It is not possible to directly describe remote I/O devices (RX/RX) in a sequence program.
- Remote I/O and programmable controller CPU devices are updated automatically based on the assignments set in the network parameters. This action is called Automatic refresh.

Using the Automatic refresh function, you are able to carry out programming as if you are accessing the modules mounted on the base.

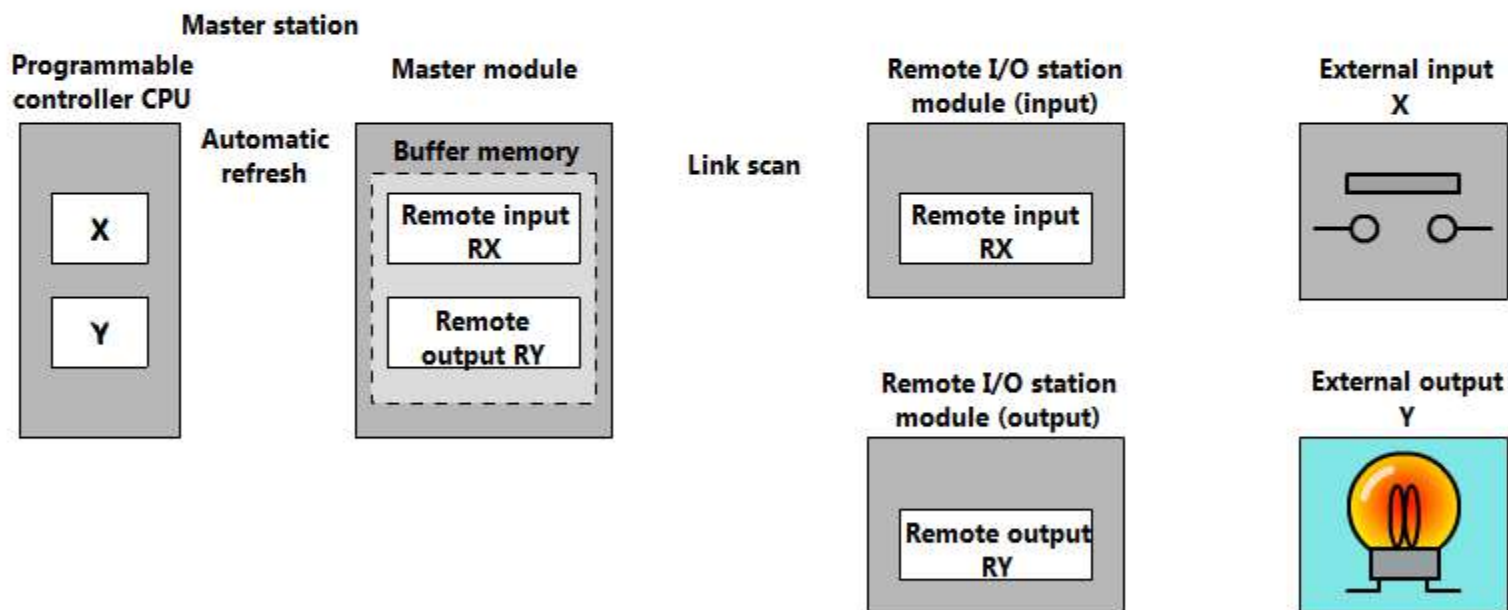

#### Link scan:

An action by which the master station scans the status of the slave stations through the network (link). A series of operations from sending data from the master station to receiving it by each slave station is carried out. In general, the less the number of total devices being connected, the less the link scan time, improving the response of remote I/O devices.

In this chapter, you have learned the following.

- Necessity of FA networks
- CC-Link family and the position of CC-Link
- Features of CC-Link
- Two data communication methods
- Types of components
- Configuration of CC-Link
- Relationship between the devices for remote I/O and programmable controller CPU

Point

|                           |  |
|---------------------------|--|
| Type of station           | <ul style="list-style-type: none"><li>• There are four types of stations: master stations, remote I/O stations, remote device stations, and intelligent device stations (including local stations).</li><li>• Remote I/O stations and remote device stations are collectively named remote stations.</li></ul> |
| Data communication method | There are two transmission methods: cyclic (cyclically communication) and transient (communication upon requests).   |
| Automatic refresh         | The data on the devices on the network will be transferred automatically to the devices on the programmable controller CPU by network parameters.  |

## Chapter 2 Specifications and Settings

This chapter describes the specifications and settings of CC-Link.

For details, see "User's manual for CC-Link system master and local module (details)."

2.1 The Concept of Number of Occupied Stations, Station Numbers, and the Number of Modules

2.2 Settings for Hardware and Software

2.3 Summary of this Chapter



## 2.1 The Concept of Number of Occupied Stations, Station Numbers, and the Number of Modules

This section describes the basic terms used in CC-Link systems.

You need to take them into account for setting network parameters later.

|                             |   |
|-----------------------------|---|
| Number of occupied stations | This is specified in advance according to the numbers of I/O in the slave stations to be used.  |
| Station No.                 | This is the unique number assigned for a device to be connected. Station No. "0" is fixed for the master station.<br>The station number starts from 1. The next station number to be assigned is the previous station number + the number of occupied stations of the previous station. |

Example: For the module in which the station number is 3 as shown in the below figure:

The station number of the host station (3) = The beginning of the previous station number (1) + Its number of occupied stations (2).

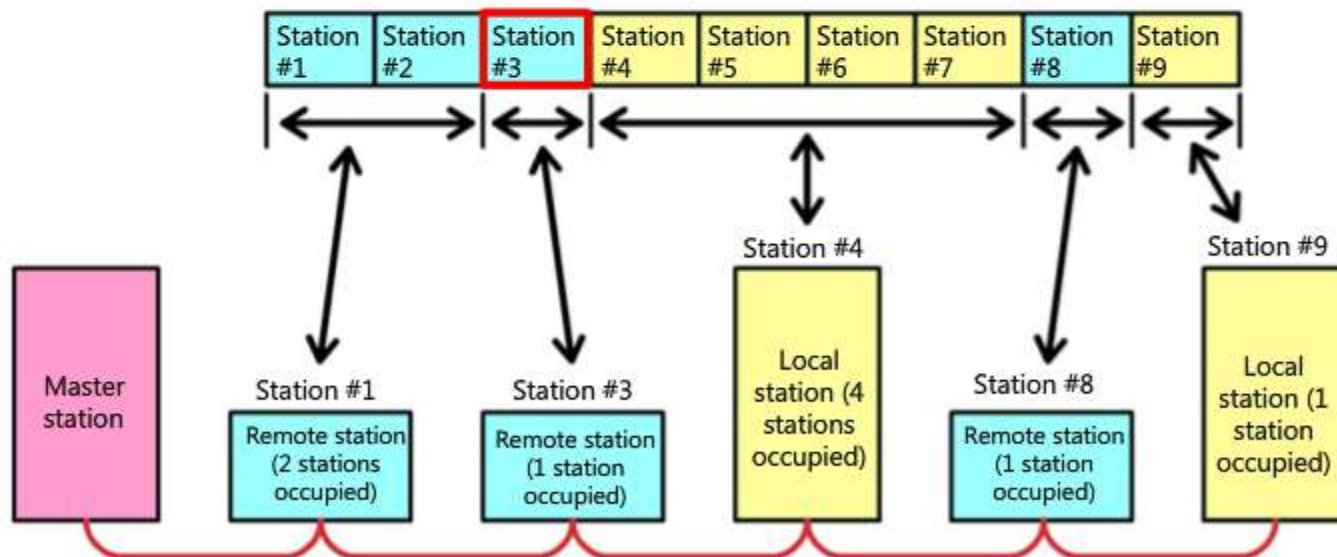

Modules are counted as 1, 2, etc. The number of modules shows how many of the modules are used.

A typical remote I/O station has one station/module.

The following settings need to be made to each module in order to operate CC-Link systems.

### Hardware settings

- Station number, mode<sup>\*1</sup>, and transmission speed<sup>\*2</sup> are set in accordance with the specifications of the data link to be set in the master station.

### Software settings

- The initial actions for each module are set.
- Settings labeled as initial settings determine the operation of a module and differ depending on the type of the module to be configured.

**\*1 Mode:**

Roughly divided into three categories: online (normal operation), offline (separated from the line), and TEST MODE.

**\*2 Transmission speed:**

The transmission speed of CC-Link advances in steps from 156 kbps to 10 Mbps. However, there can be incompatibility in the relationship among transmission speeds, transmission distances, and noise resistance. The higher the transmission speed, the shorter the transmission distance and the lower the noise resistance.

Therefore, you need to select the highest transmission speed to fulfill the total extended distance calculated based on the installation layout of a CC-Link.

If noise impacts actual operation, reduce the transmission speed further after implementing measures against noise.

### Hardware settings

Follow the procedure below.

Connect each module with dedicated CC-Link cables.



Set the switches of the modules.

#### Remote modules

- Station No. setting switch
- Transmission speed setting switch

#### Master/local modules

- Station No. setting switch
- Transmission speed setting switch
- Mode setting switch



The hardware has been prepared.

### Software settings

Select settings using an engineering tool for the programmable controller CPU that controls the master station.

Settings can be carried out in the network parameters.

The following items can be set with the network parameters.

- Top I/O number that indicates the installation position of the master module.
- Total number of connected modules (slave stations), number of retries<sup>\*1</sup>, and station information settings<sup>\*2</sup>, which relate to the basic operation of a network.
- Automatic refresh parameters for the purpose of making an association between the programmable controller CPU and the CC-Link's link device<sup>\*3</sup>.

#### \*1 Number of retries:

In CC-Link, its reliability for data is maintained by retrying (resending) data transmissions if a loss of data due to noise, etc. is detected. The number of retries is set to a value of indicating how many detections of data losses in a particular station are allowed continuously.

The higher the number of retries, the higher the rate of continuous communication with the relevant station. It can be thought, however, that the occurrence of frequent retries indicates that there is a problem such as noise. Therefore, you should try to solve it at the same time.

#### \*2 Station information setting:

Sets the attributes of a device (slave station) being connected with the CC-Link. The attributes include the type of station and the number of occupied stations described before.

#### \*3 Link device:

The collective term of RX/RX and RWr/RWw. RWr/RWw are the word devices to be used in the link.

**2.3****Summary of this Chapter**

In this chapter, you have learned the following.

- The meaning of the number of occupied stations, station number and the number of modules.
- Settings necessary for operation, hardware and software settings

**Point**

|                             |   |
|-----------------------------|---|
| Number of occupied stations | <ul style="list-style-type: none"><li>• The number of occupied stations for remote I/O modules is generally 1.</li><li>• The station numbers are affected by the number of occupied stations.</li><li>• The number of modules shows the number of slave stations.</li></ul> |
| Transmission speed          | <ul style="list-style-type: none"><li>• There is incompatibility between transmission distance and transmission speed.</li><li>• It has to be determined according to the required response speed and operating environment.</li></ul>                                      |

## Chapter 3 Launching the remote I/O system

This chapter describes how to launch the CC-link system using a practice system. You will learn the settings and operations of modules through the configuration of the practice system.

- 3.1 Overview of the Practice System
- 3.2 Hardware Settings for the Master Module
- 3.3 Hardware Settings for the Remote I/O Modules
- 3.4 Wiring
- 3.5 Parameter Settings
- 3.6 Confirmation of Specifications
- 3.7 Creating a Sequence Program
- 3.8 Operation Check
- 3.9 Primary Diagnostics
- 3.10 Detailed Diagnostics
- 3.11 Summary of this Chapter

## 3.1

## Overview of the Practice System



## Overview of the operation of the practice system

- Allow the status of RX1 (slave station, station No. 1) to be displayed on the output on the master station side.
- Turning on X2 on the master station causes RY2 of the slave station (station No. 2) to turn on.
- Allow the communication status of the slave stations to be displayed on the output on the master station side.
- If an error occurs in the master module, no remote I/O is processed.

## Overall configuration

The following shows the configuration of the practice system.

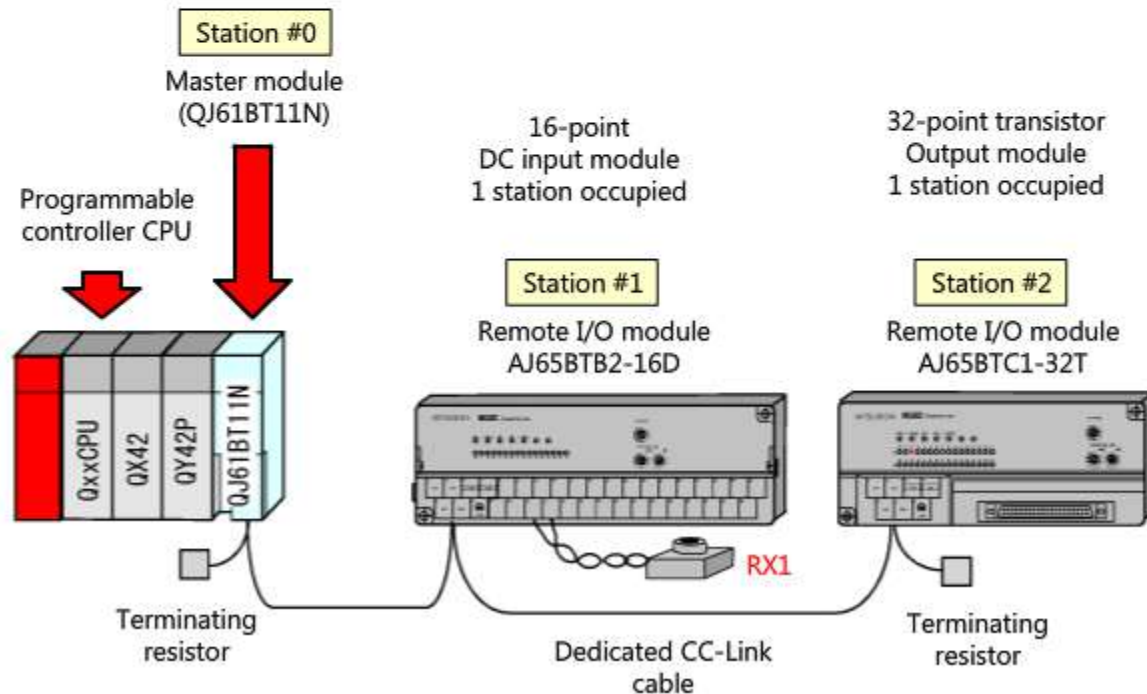

## 3.2

## Hardware Settings for the Master Module

This section describes the settings of a CC-Link master and local module (Model: QJ61BT11N) and its display.

## Settings

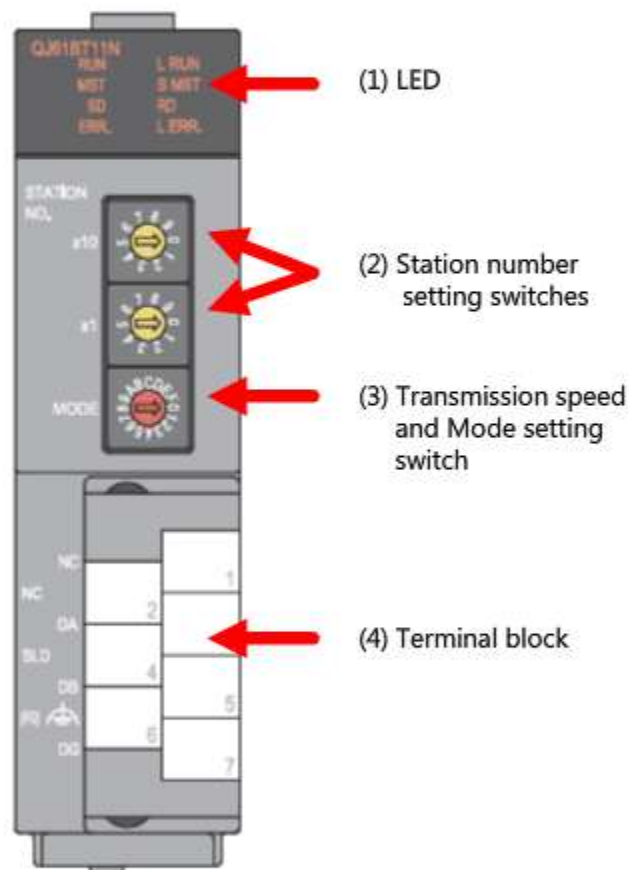

|     | Settings contents   |
|-----|---|
| (1) | The area to display the operating status. Primary diagnostics is enabled if there is an operating failure.    |
| (2) | As the station number of the master station is designated as "0," set "0" for both of the digits of 10 and 1. |
| (3) | Set this to online "0."<br>(Online mode/transmission speed: 156 kbps)   |
| (4) | Connect dedicated CC-Link cables.   |



## 3.3

## Hardware Settings for the Remote I/O Modules

## Input module

An input module is used as an example in this explanation.

## Settings

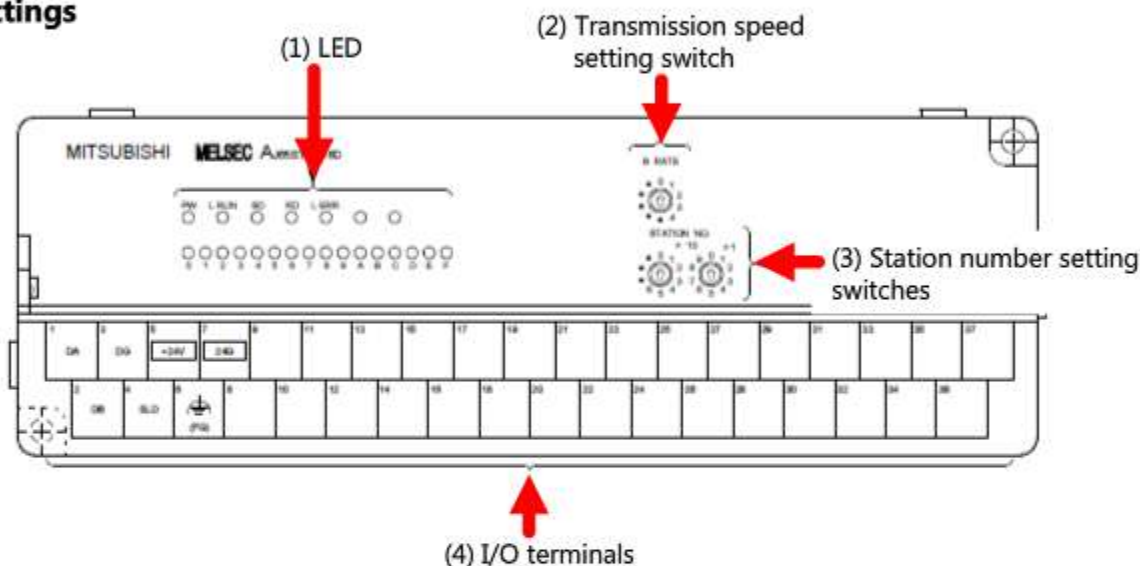

| Settings contents |   |
|-------------------|---|
| (1)               | The area to display the operating status. Primary diagnostics is enabled if there is an operating failure.        |
| (2)               | Set the transmission speed to 156 kbps (Setting number: 0).   |
| (3)               | Set the station number so that it is not the same as that of other stations.                                      |
| (4)               | Connect dedicated CC-Link cables on the left. The terminals for connecting I/O devices are arranged on the right. |

# 3.4 Wiring

Please carry out necessary wiring as shown below.

- Wiring to each module in the CC-Link  
*It is not necessary to wire in the order of station numbers.*
- Connect terminating resistors (110 Ω, 1/2 W (color code: brown, brown, brown)) to the stations on both sides of the transmission line.
- Supply external power (DC 24 V) to the slave stations.

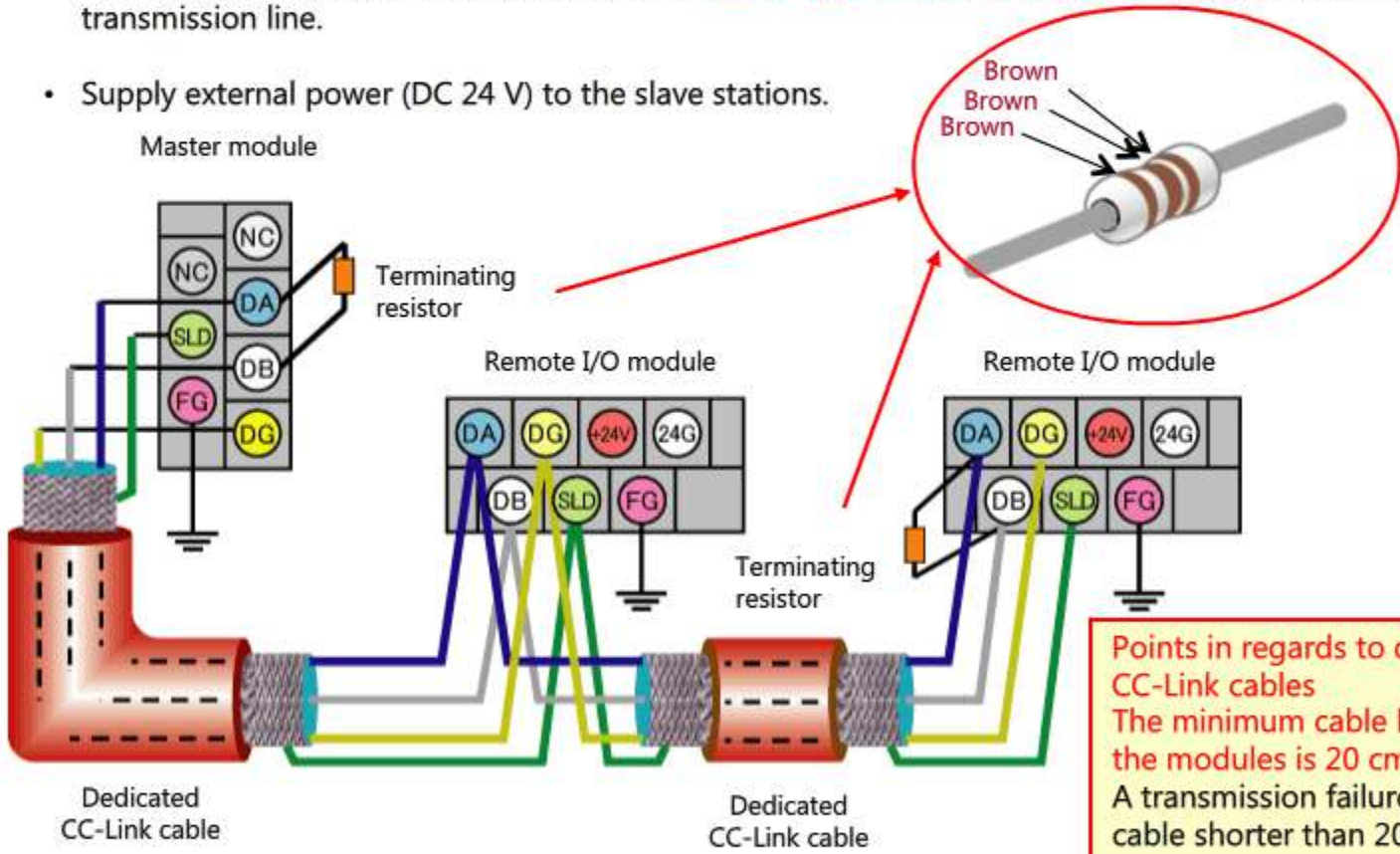

Points in regards to dedicated CC-Link cables  
 The minimum cable length between the modules is 20 cm.  
 A transmission failure may occur if a cable shorter than 20 cm is used.

**3.5****Parameter Settings****Starting up GX Works2**

After confirming that the hardware is launched, set parameters using the engineering tool, GX Works2. Although you are also able to perform settings using sequence programs, this section provides explanations in a visually understandable manner.

## Parameter settings for CC-Link

This section describes how to set network parameters.

Select "CC-Link" from "Network Parameter" to open the Network parameter CC-Link window.

Set the operating mode and version of the CC-Link. Modify the settings in accordance with the scale and purpose of the system. The most common mode is the "Remote Net(Ver. 1 Mode)".

Selecting this checkbox allows you to set the slave station information in a visually understandable manner.

|                                       |   |        |                    |
|---------------------------------------|---|--------|--------------------|
| Number of Modules                     | 1   | Boards | Blank : No Setting |
| Start I/O No.                         | 0080  |        |                    |
| Operation Setting                     | <input checked="" type="checkbox"/> Set the station information in the CC-Link configuration window |        |                    |
| Type                                  | Master Station  |        |                    |
| Master Station Data Link Type         | Remote Net(Ver. 1 Mode)   |        |                    |
| Mode                                  | Remote Net(Ver. 1 Mode)   |        |                    |
| Total Module Connected(*1)            | 2   |        |                    |
| Remote input(RX)                      | X 100   |        |                    |
| Remote output(RY)                     | Y 100   |        |                    |
| Remote register(RWr)                  |   |        |                    |
| Ver. 2 Remote input(RX)               |   |        |                    |
| Ver. 2 Remote output(RY)              |   |        |                    |
| Ver. 2 Remote register(RWr)           |   |        |                    |
| Special relay(SB)                     | SB0   |        |                    |
| Special register(SW)                  | SW0   |        |                    |
| Retry Count                           | 3   |        |                    |
| Automatic Reconnection Station Count  | 1   |        |                    |
| Standby Master Station No. (*1)       |   |        |                    |
| PLC Down Select                       | Stop  |        |                    |
| Scan Mode Setting                     | Asynchronous  |        |                    |
| Delay Time Setting                    | 0   |        |                    |
| Station Information Setting           | CC-Link Configuration Setting   |        |                    |
| Remote Device Station Initial Setting |   |        |                    |
| Interrupt Settings                    |   |        |                    |

Set the top I/O number of the master module to 0080h according to "3.1 Overview of the Practice System."

The number of slave stations is shown here. When the "Station information" is set, it is reflected automatically.

Assign the empty area of I/O devices X/Y as the targets to automatic refresh. They are set as the targets for refreshing remote I/O from X/Y100, as I/O up to X/Y9F on the base have been assigned in "3.1 Overview of the Practice System."

Link special relay (SB) and link special register (SW) are the fields for communicating information such as the operating status of the network modules. They are used as interlocks on the program and other purposes.

Register the information of the slave stations such as station numbers and the number of occupied stations. They are described concretely in the next page.

Network Parameter screen

## 3.5 Parameter Settings

### Configuration of CC-Link

In this section, you will set the configuration of the CC-Link.

Select the relevant modules from the list of modules shown on the right and drag and drop them from Station No. 1 in order. The number of occupied stations is calculated and each station number is set automatically.

The settings process is completed after selecting the module name according to "3.1 Overview of the Practice System."

CC-Link Configuration Module 1 (Start I/O: 0080)

CC-Link Configuration Edit View Close with Discarding the Setting Close with Reflecting the Setting

Mode Setting: Ver. 1 Mode TX Speed: 159kbps Link Scan Time (Approx.): 7.74 ms

| Station No. | Model Name   | Station Type       | Version | # of STA Occupied  | Expanded Cyclic Setting |
|-------------|--------------|--------------------|---------|--------------------|-------------------------|
| 1/1         | AJ65BTB2-16D | Remote I/O Station | Ver. 1  | 1 Station Occupied | Single                  |
| 2/2         | AJ65BTC1-32T | Remote I/O Station | Ver. 1  | 1 Station Occupied | Single                  |

Module List

Select CC-Link Find Module My Favorites

Category to be refined

Output Module (40-pin Connector Type(FON

Search String \* Partial match search is possible

AJ65BTC

Please input within 32 characters.

Find from model name and outline specification. Search

Find Result

AJ65BTC1-3 32 points (Transistor output)

Host Station

STA#1 STA#2

STA#0 Master Ver. 1 All Connect Count 2 Total STA#2

AJ65BTB2-1 6D AJ65BTC1-3 2T

Drag and drop

[Outline] Transistor output module (40-pin connector type(FON connector type))

[Specification] Transistor output 32 points, sink type, 0.1A

CC-Link Configuration setting screen

## 3.6 Confirmation of Specifications

This section describes the following points to be observed before actually starting programming.

### Confirmation of the station number setting status for slave stations.

Confirm the setting of the station number for each slave station.



Station #1: Remote I/O station  
(AJ65BTB2-16D, 16-point, DC input)



Station #2: Remote I/O station  
(AJ65BTC1-32T, 32-point, transistor output)

## 3.6

## Confirmation of Specifications

## Check points (device compatibility)

## Caution

Apart from that bit devices are secured for 32 points worth per station, as Station No. 1 is a remote input 16-point module, the range between X110 and X11F is not used.

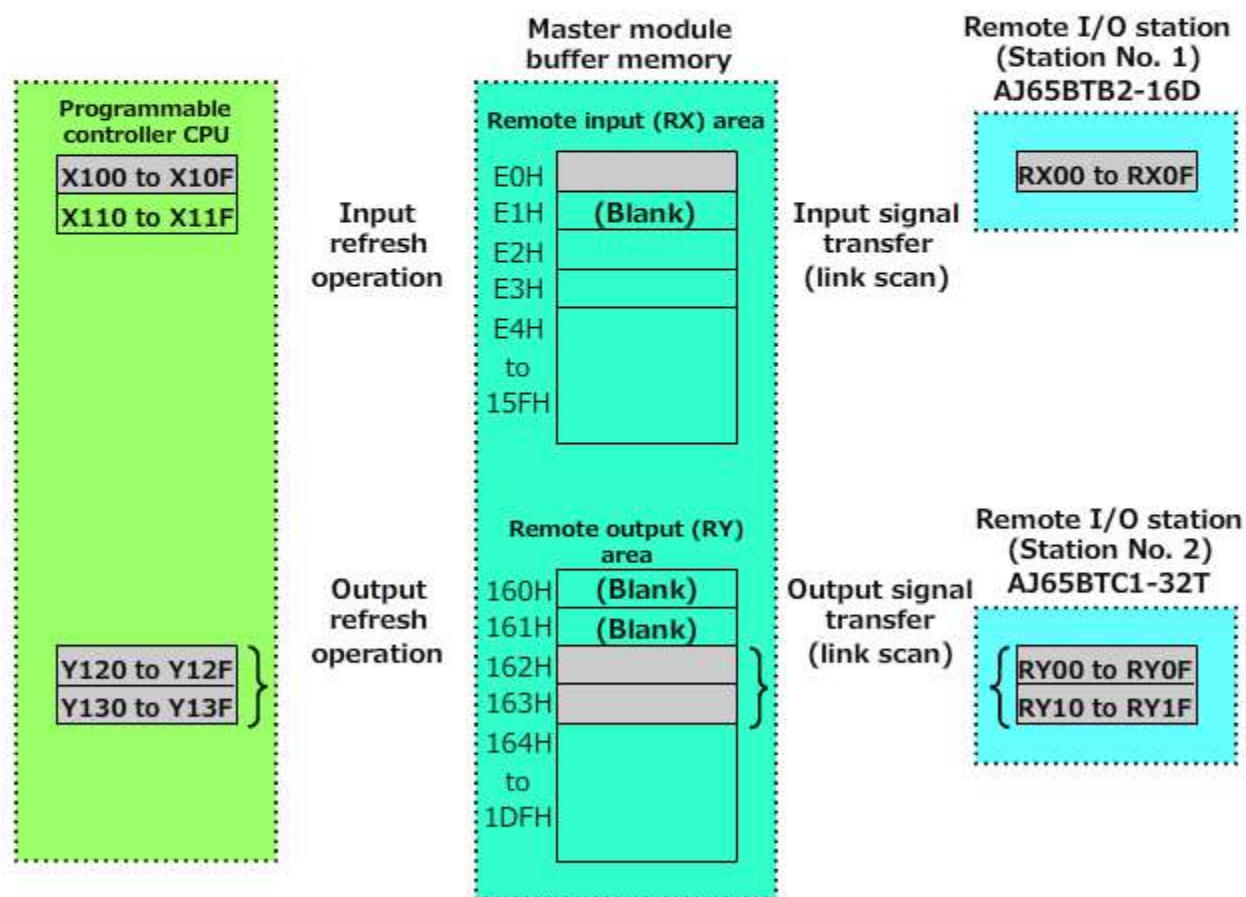

### Confirmation of the relationships between the devices

In the practice system, the top of the remote input refresh device is set to X100, and the top of the remote output refresh device is set to Y100.

The relationships of RX/RX of the remote I/O stations and the devices of the programmable controller CPU are as follows.

#### Assignment of Remote input RX

| Remote station |                                  |  | Programmable controller CPU |
|----------------|----------------------------------|--|-----------------------------|
| Station No.    | Module name                      | Remote input (RX)                              | Device                      |
| 1              | AJ65BTB2-16D<br>(16-point input) | RX00 to RX0F (Remote)<br>RX00 to RX0F (Master) | X100 to X10F                |
|                |                                  | Not used                                       | X110 to X11F                |

#### Assignment of Remote output RY

| Remote station |                                   |   | Programmable controller CPU |
|----------------|-----------------------------------|---|-----------------------------|
| Station No.    | Module name                       | Remote output (RY)                            | Device                      |
| 2              | AJ65BTC1-32T<br>(32-point output) | RY0 to RY1F (Remote)<br>RY20 to RY3F (Master) | Y120 to Y13F                |



# 3.7 Creating a Sequence Program

## Example sequence program

A sequence program for the practice system is shown below.

Steps 0 to 6: The sequence program has been assembled so that the subsequent processes take place when the status of the master module is read and the conditions by which the master module can operate are met.

[Maser control]  
When M800 becomes active, the range between N0 M800 and MCR N0 is activated.

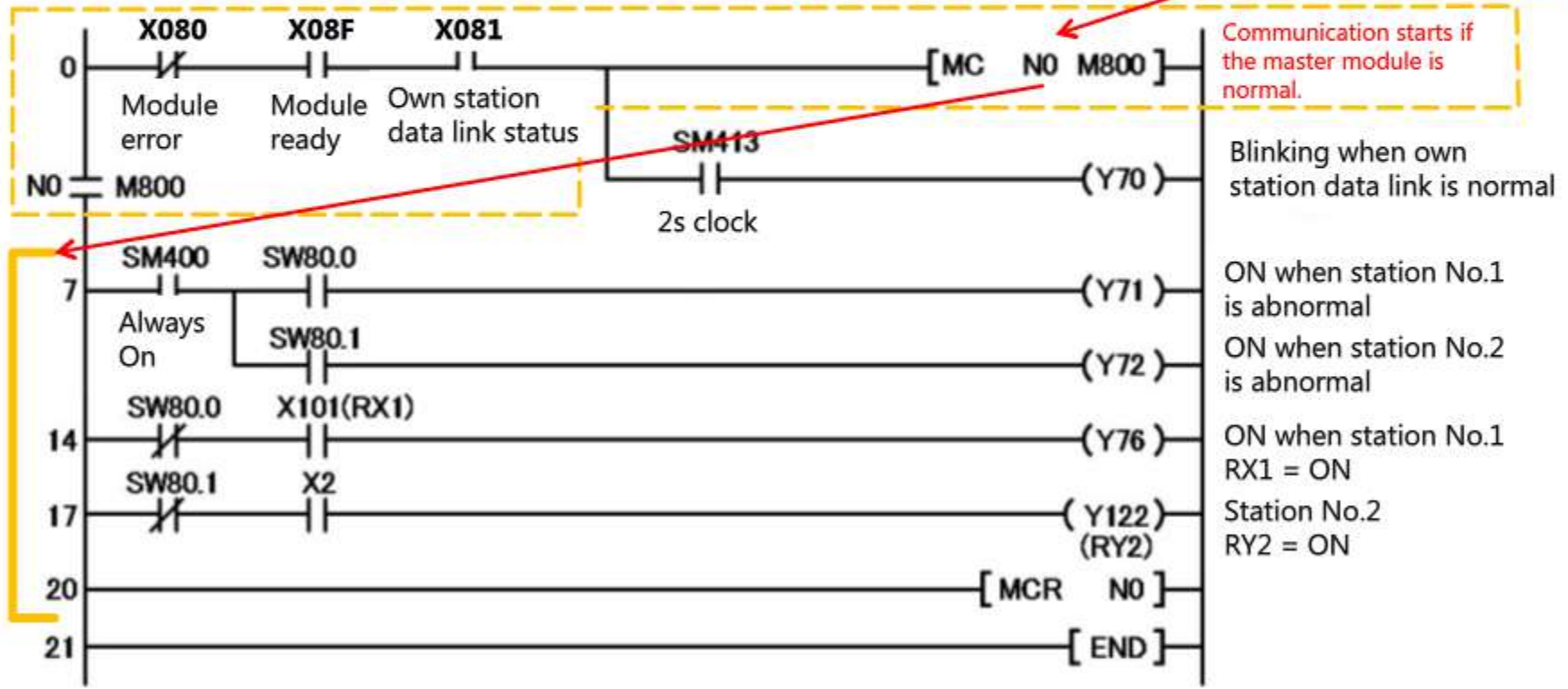

# 3.7 Creating a Sequence Program

## Example sequence program (continued)

Steps 7 to 13: The status of each station is read. Either one or both master module output devices Y71 or Y72 is/are output according to the station in which an error is issued.

The data link status of each station is stored.  
 0: Normal  
 1: A data link error is issued.

The number in each grid shows the station No.

|        | b15 | b14 | b13 | b12 | ~ | b3 | b2 | b1 | b0 |
|--------|-----|-----|-----|-----|---|----|----|----|----|
| SW0080 | 16  | 15  | 14  | 13  | ~ | 4  | 3  | 2  | 1  |
| SW0081 | 32  | 31  | 30  | 29  | ~ | 20 | 19 | 18 | 17 |
| SW0082 | 48  | 47  | 46  | 45  | ~ | 36 | 35 | 34 | 33 |

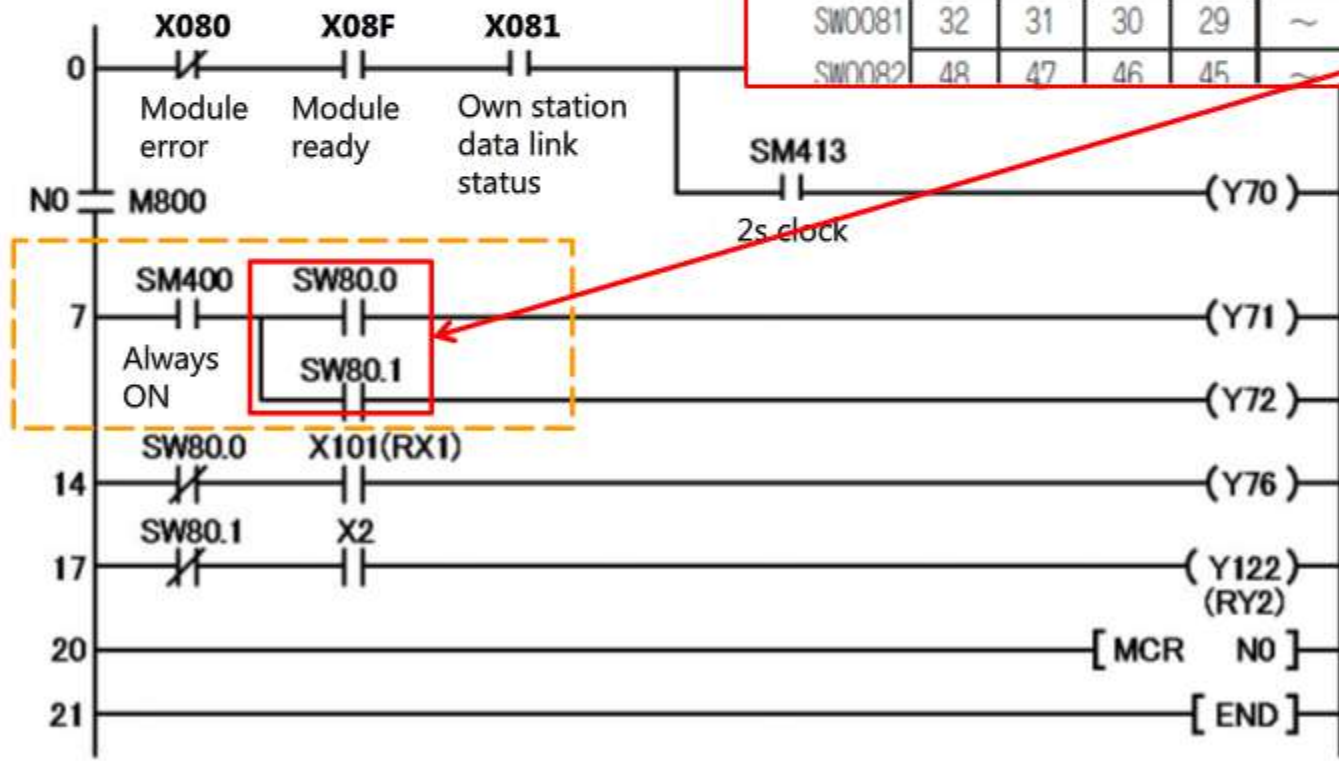

- (Y70) Blinking when own station data link is normal
- (Y71) ON when station No.1 is abnormal
- (Y72) On when station No.2 is abnormal
- (Y76) ON when station No.1 RX1 = ON
- (Y122) (RY2) Station No.2 RY2 = ON

### Example sequence program (continued)

Steps 14 to 19: Signals are I/O to/from the slave stations of the CC-Link.

X101: Corresponds to Input module RX1 of Station No. 1.

Y122: Corresponds to Output module RY2 of Station No. 2.

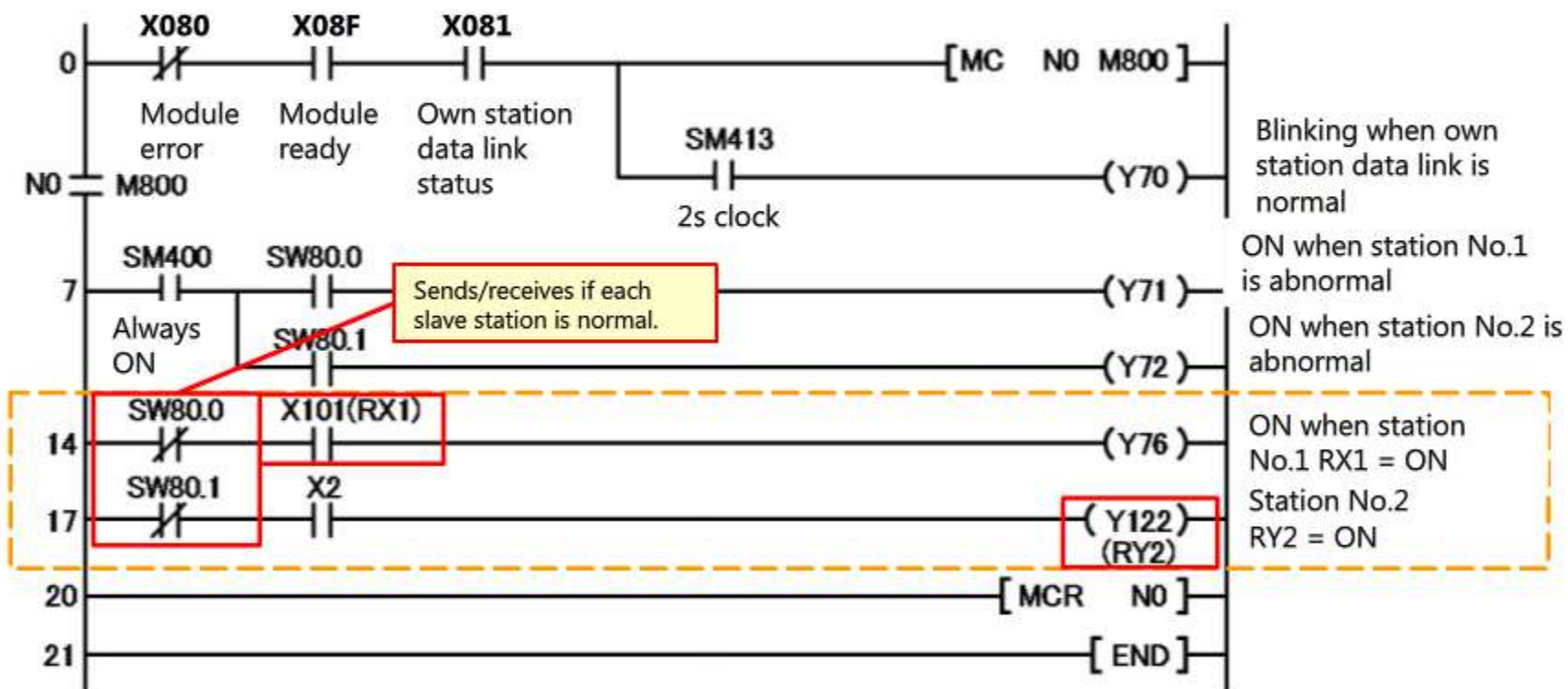

## 3.8

## Operation Check

In this section, you will confirm the operation of the practice system.

## Details of operation

1. If the data link status is **normal**, LED Y70 of Master station QY42P blinks.
2. When Switch **RX1** of AJ65BTB2-16D is turned on, LED Y76 of Master station QY42P comes on.
3. When **X2** is forcibly turned on by modifying the present value (PV) with GX Works2, the LED of "Terminal number A2" (RY2) of Station No. 2 AJ65BTC1-32T comes on.

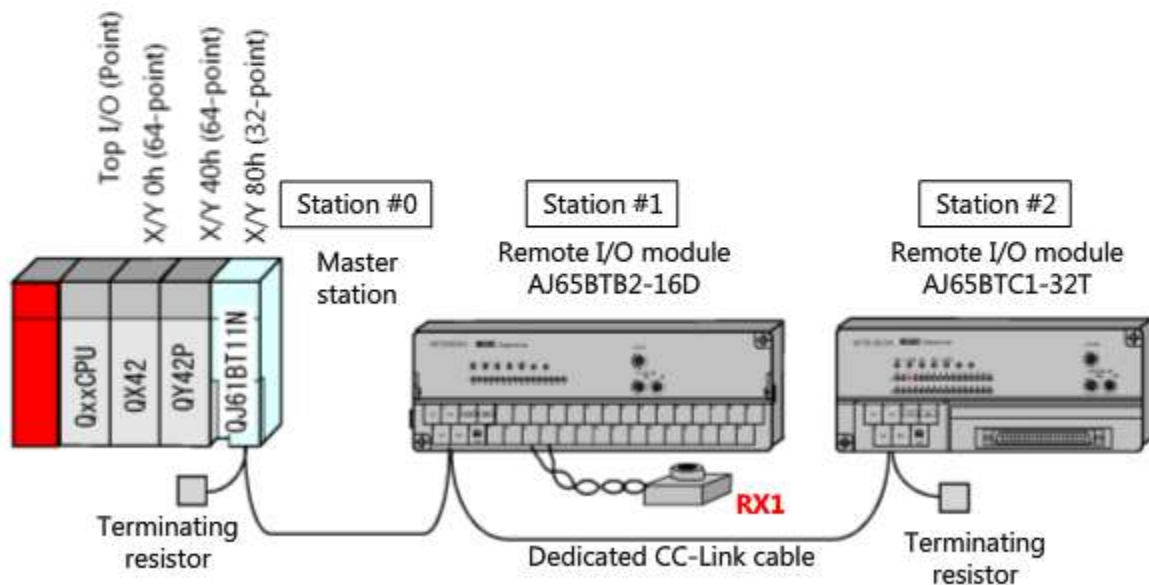
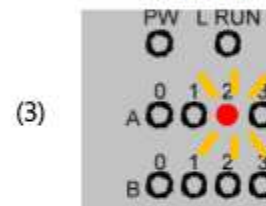
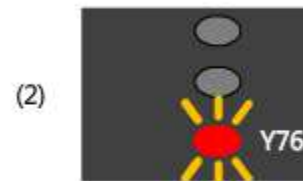

### Primary diagnostics of operation through LED indications

If the expected operation has not taken place, such as no remote I/O station is output, it is possible to conduct primary diagnostics through observing LED indications on the module.

#### Master station

The status of the master station is indicated with LEDs when the data link is normal. If it does not operate normally, check if the LEDs are indicated as shown below.

- If either or both of SD/RD do(es) not come on, check the wiring of the dedicated CC-Link cables including terminating resistors.
- If L RUN does not come on, there may be a problem in the setting.
- If MST does not come on, check the mode switch, as the module may not be set as the master station.
- If RUN does not come on, the module may not operate normally.



# 3.9 Primary Diagnostics

## Primary diagnostics of operation through LED indications

### Remote I/O station

The status of the remote I/O station is indicated with LEDs when the data link is normal. If it does not operate normally, check if the LEDs are indicated as shown below.

- If either or both of SD/RD do(es) not come on, check the wiring of the dedicated CC-Link cables including terminating resistors.
- If L RUN does not come on, there may be a problem in the setting.
- If PW does not come on, there may be no power supplied to the module.



## 3.10 Detailed Diagnostics

### Diagnostics using an engineering tool

If the problem persists even if primary diagnostics using LEDs is conducted, use the diagnostic function of the engineering tool, GX Works2, to investigate in more detail. The following shows the CC-Link Diagnostics screens.



CC-Link Diagnostics screen

Normal



CC-Link Diagnostics screen

Error

## 3.11 Summary of this Chapter

In this chapter, you have learned the following.

- Master module setting
- Remote I/O module setting
- Wiring
- Parameter settings
- Confirmation of specifications
- Programming
- Operation check
- Primary diagnostics
- Line monitor

### Point

|                                     |  |
|-------------------------------------|--|
| Station number of the master module | The station number of the master module must be "0."   |
| Transmission speed                  | Be sure to set an identical transmission speed in the same system (With that of the master station). |
| Station No.                         | Set it in order from 1 so as not to be duplicated with the others.                                   |
| Connection of terminating resistors | Be sure to connect terminating resistors to both ends of the transmission lines.                     |



## Chapter 4 Expandability and Reliability of CC-Link

You have learned so far about the simple procedure from launching a remote I/O device to diagnosing it. However, when using real-world systems on site, you may have to cope with the following situations other than the communication of bit data you have learned in this course.

- Communication of analog data
- Data communication between programmable controller CPUs
- Operation of the display and using it to display the status.
- Extending the distance

CC-Link can be used for them without any problems.

When configuring an actual system, you want to avoid impact to the lines and systems caused by a stoppage of the CC-Link.

In response to such concerns, the following functions are available in CC-Link in order to enhance the reliability of your network.

- Stand-by master station
- Slave station disconnection
- Auto-replication
- 2-piece terminal block

These are described in detail in the next page and onward.

4.1 Stand-by Master

4.2 Slave Station Disconnection

4.3 Auto-Replication

4.4 2-Piece Terminal Block

4.5 Summary of this Chapter

# 4.1 Stand-by Master

As the master station takes a crucial role in communication, the data link stops if the master station stops abnormally. By preparing a stand-by master station, the data link can be used continuously in the event of an error occurring in the master station.

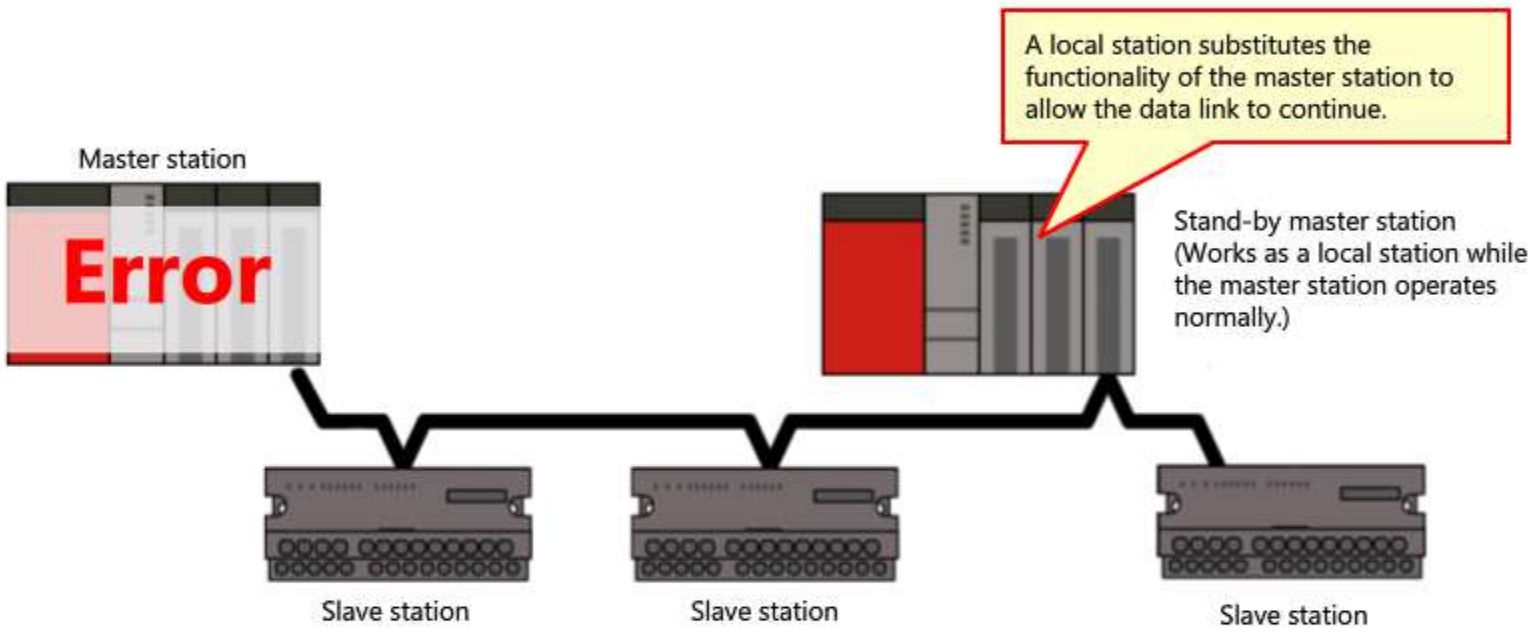

## 4.2

## Slave Station Disconnection

While the data link is activated, if an error has occurred in a slave station and the data link is deactivated, the slave station in question is disconnected and the data link continues only using the normal stations.

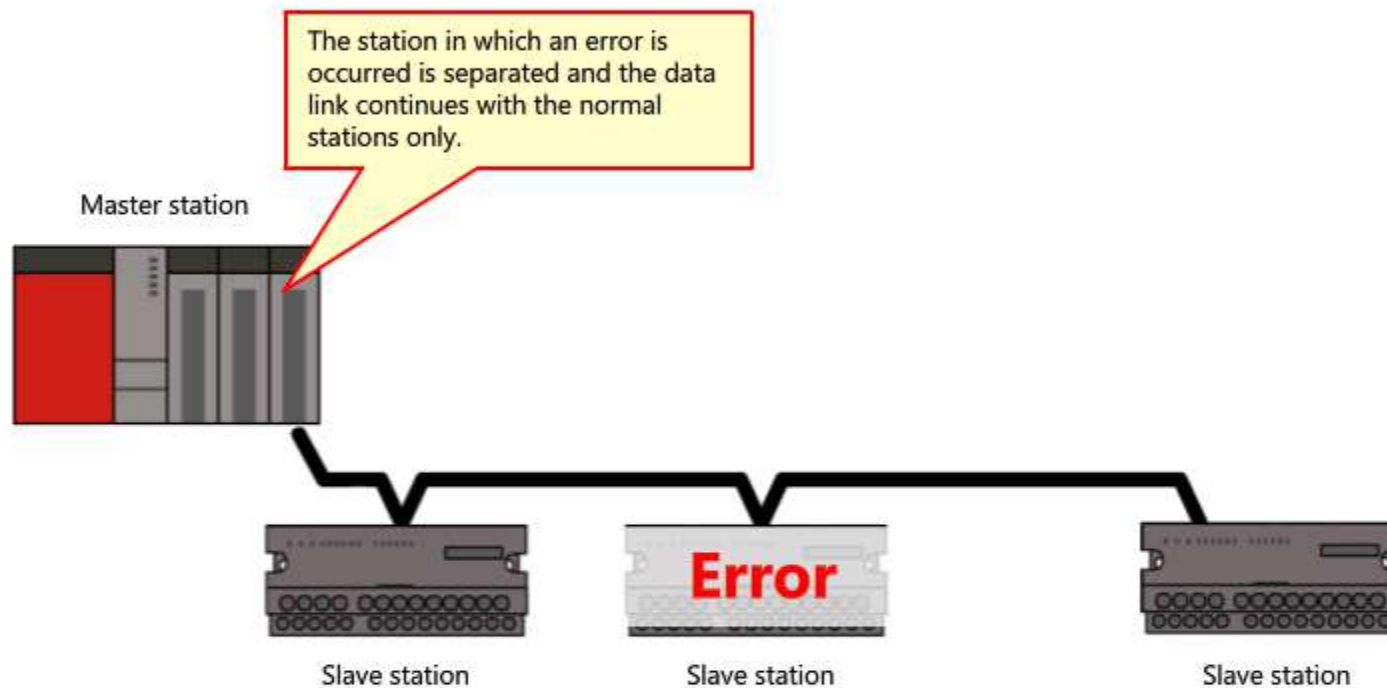

# 4.3 Auto-Replication

When the station that was separated from the data link due to an error returns to normal operation, it is automatically returned to the data link. This action is called "Auto-replication." Restarting of the entire system is not required when recovering.

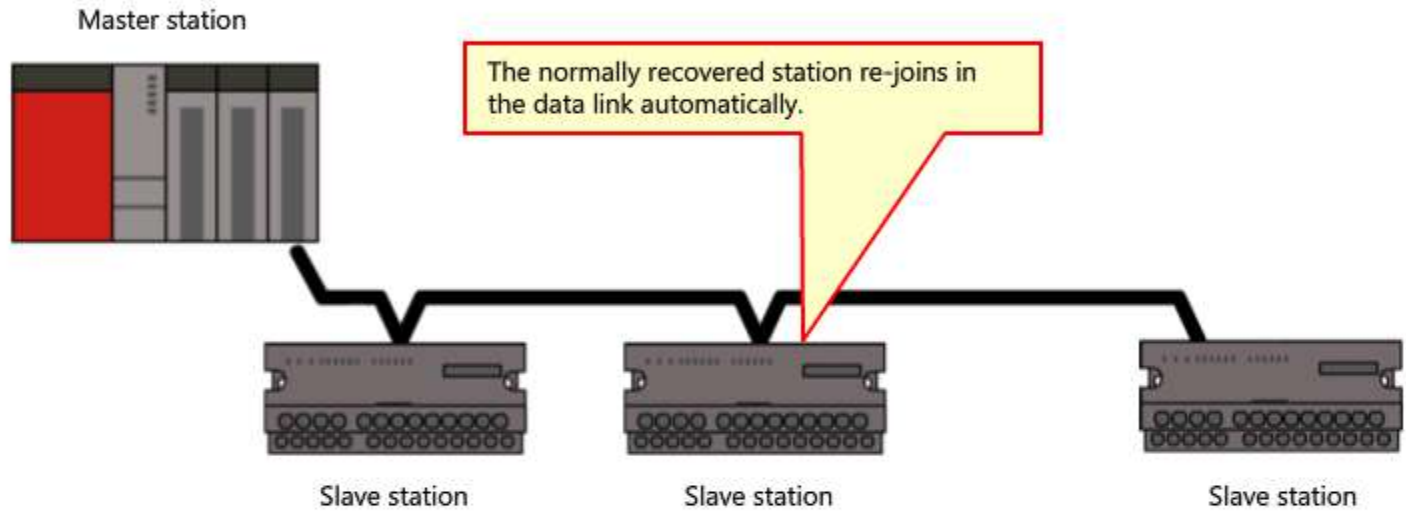

**Error** → **Recovered**

# 4.4 2-Piece Terminal Block

In each module in CC-Link, in addition to "Slave station disconnection" and "Auto-replication," etc., it also has a safe structure by which the terminal block for the dedicated CC-Link cable can easily be removed from the main body of the module without affecting the other normal stations.



## 4.5 Summary of this Chapter

In this chapter, you have learned the following.

- Expandability of CC-Link
- Reliability of CC-Link

### Point

|                             |   |
|-----------------------------|---|
| Expandability of CC-Link    | <ul style="list-style-type: none"><li>• In addition to remote I/O devices described at this time, you are able to connect other equipment such as analog devices, high speed counters, positioning machines, and displays.<br/>Also, it is equipped with necessary functionality for FA networks, which allows various operations, such as communication between PLCs.</li><li>• You can extend the distances according to your requirements.</li></ul> |
| Stand-by master             | By specifying a local station as the stand-by master station, it substitutes the functionality of the master station if an error has occurred in the master station.  |
| Slave station disconnection | Disconnects the slave station in which an error has occurred from the link.   |
| Auto-replication            | Allows re-joining of the slave station to the link when recovered from an error state.  |
| 2-piece terminal block      | You can remove the terminal block for connecting dedicated CC-Link cables from the module.<br>By combining this function with the settings of "Slave station disconnection" and "Auto-replication," etc., you are able to replace the module without applying any impact to communications.   |

Now that you have completed all of the lessons of the **PLC CC-Link** Course, you are ready to take the final test. If you are unclear on any of the topics covered, please take this opportunity to review those topics.

There are a total of 6 questions (6 items) in this Final Test.

You can take the final test as many times as you like.

### How to score the test

After selecting the answer, make sure to click the **Answer** button. Your answer will be lost if you proceed without clicking the Answer button. (Regarded as unanswered question.)

### Score results

The number of correct answers, the number of questions, the percentage of correct answers, and the pass/fail result will appear on the score page.

Correct Answers : 2

Total Questions : 9

Percentage : 22%

To pass the test, you have to answer **60%** of the questions correct.

Proceed

Review

Retry

- Click the **Proceed** button to exit the test.
- Click the **Review** button to review the test. (Correct answer check)
- Click the **Retry** button to retake the test again.

Please select the item that most represents the features of CC-Link. (Select only one item.)

- CC-Link only allows the connection of products manufactured by Mitsubishi Electric Corporation.
- The functionality available in CC-Link is limited to remote I/O.
- CC-Link specifications are open to the public and can be combined with a variety of products to allow a wide range of desired systems.

[Answer](#)[Back](#)



## Test

## Final Test 2

There is a CC-Link system with QJ61BT11 designated as the master station. It is configured to have a 16-point input Station No. 1, and a 32-point input Station No. 2.

When the top of the refresh device for a remote input (RX) is set to X100 of the PLC device, where will RX0 of Station No. 2: 32-point input module be refreshed in the PLC device? (Select only one item.)

Device assignment for Remote input RX

| Remote station |                                  |                | Programmable controller CPU | Master module |
|----------------|----------------------------------|----------------|-----------------------------|---------------|
| Station No.    | Module name                      | RX             | Device                      | Buffer memory |
| 1              | AJ65BTB2-16D<br>(16-point input) | RX00 to RX0F   | X100 to X10F                | E0H           |
|                |                                  | (Blank)        | X110 to X11F                | E1H           |
| 2              | AJ65BTB1-32D<br>(32 point input) | (RX00 to RX0F) | (???)                       | E2H           |
|                |                                  | (RX10 to RX1F) | (???)                       | E3H           |

- X110  
 X120  
 X130  
 M100

Please select a correct data communication method that can be used in CC-Link. (Select only one item.)

- Cyclic transmission only
- Transient transmission only
- Cyclic transmission and transient transmission

Answer

Back

## Test

## Final Test 4



Please select the stations that require the connection of terminating resistors. (Select two items.)



- Stations #0
- Station #1
- Station #2
- Station #3
- Station #4

[Answer](#)[Back](#)

Please select a correct method to apply station numbers. (Select only one item.)

- The station number for the master station can freely be set.
- The station number is set using the station number setting switch provided on a module.
- Modules have to be wired in the order of the station number.
- The station number can initially be set with parameters for slave stations.

[Answer](#)[Back](#)

Please select correct items that are included in the network parameters for CC-Link. (Select five items.)

- Station information
- Transmission speed
- Top I/O number of the master module
- Number of connected modules
- Connection positions of terminating resistors
- Number of retries
- Automatic refresh

[Answer](#)[Back](#)

You have completed the Final Test. Your results are as follows.  
To end the Final Test, proceed to the next page.

Correct answers: **0**

Total questions: **6**

Percentage: **0%**

Proceed

Review

Retry

**You failed the test.**

You have completed the **PLC CC-Link** Course.

Thank you for taking this course.

We hope you enjoyed the lessons and the information you acquired in this course will be useful in the future.

You can review the course as many times as you want.

**Review**

**Close**